



Applications

SAWING MACHINES

Our expertise for your success

Custom Solutions by ARGO-HYTOS

The Challenge

The demands posed on sawing machines – whether fully automated, semi-automated or manual – regarding speed, cutting precision and required cut surface quality keep increasing. The main focus is on the resulting controllability and modularity, as well as energy efficiency of the hydraulic systems. This combination of requirements calls for a deep understanding of the application, both in project planning and in developing system-specific components.

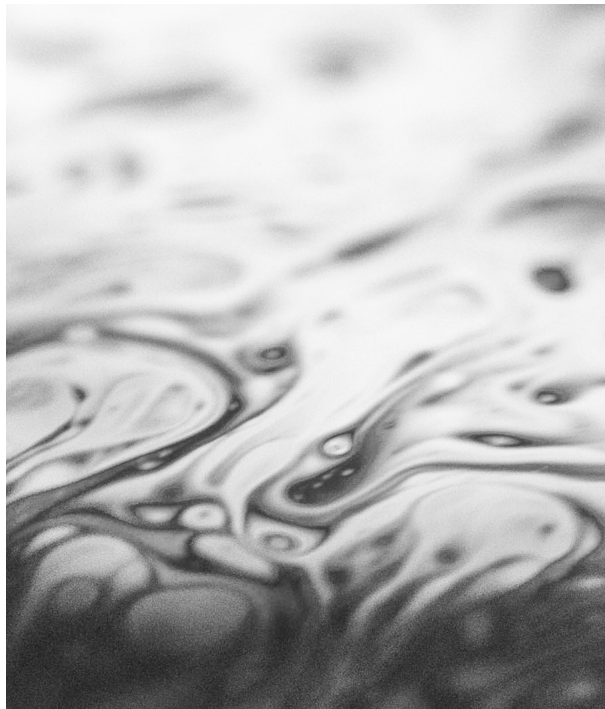

Your Custom Solution

ARGO-HYTOS offers a wide range of highly compatible filtration, valve and sensor products for your application. We adapt and modify components or individual function elements in such a way that the function in your machine is realized according to your wishes. We combine valve, filter and sensor technology to create subsystems and compact function units, which help you reduce assembly and piping costs. We are able to react quickly and flexibly to specific customer and market demands thanks to our considerable manufacturing expertise and level of in-house production.

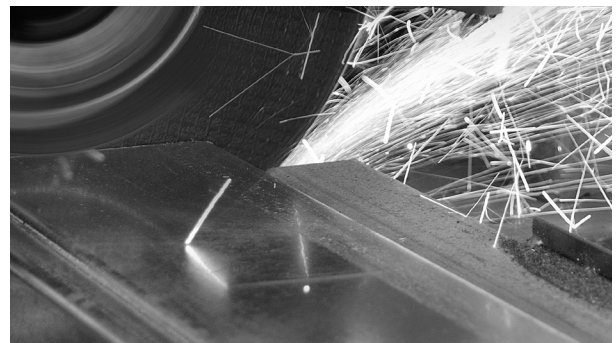

Our Expertise

ARGO-HYTOS has been working with the leading sawing machine manufacturers for decades. We closely collaborate with our customers to develop components, clever subsystems and innovative system solutions, combining sensor, filtration and valve technology. Some examples are:

- > Band tensioning
- > Clamping and locking
- > Saw feed
- > Complete power unit

In addition to pressure, temperature and flow sensors, oil condition monitoring has become more important in recent years, often in the form of portable units for servicing. One of the main reasons for this is the goal to further increase machine uptime.

The collection, transfer and analysis of data present a significant benefit for manufacturers and operators in terms of predictive maintenance.



WORKING HYDRAULICS

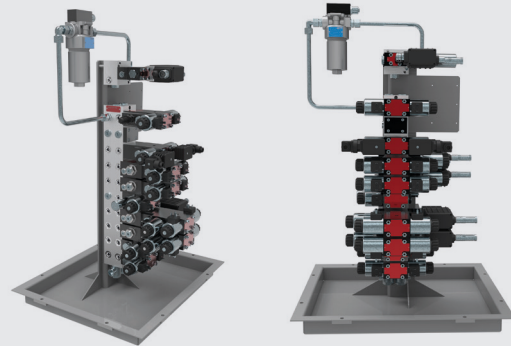

1 Custom manifolds

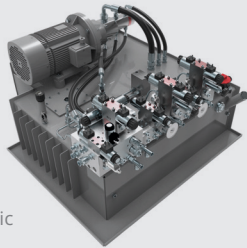

2 Custom hydraulic power units



3 Clamping pressure reduction

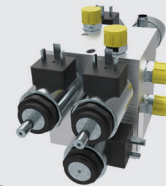

4 Band tensioning

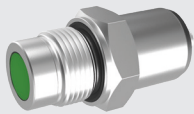

6 Wear sensors

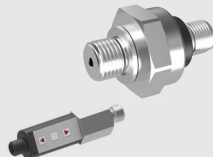

7 Pressure sensors

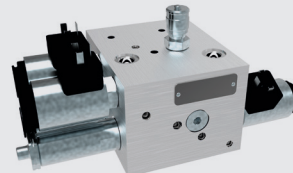

11 Vice retraction, hydr. bundle cutting attachment (top clamp)

FILTRATION

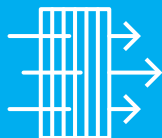

5 Suction filter



8 Filling- & ventilating filters



9 Return filter with breather



10 High-pressure filters

ARGO-HYTOS: Your project – our passion – succeeding together

- › You want to redesign, modernize or adapt your machine to a regional market – we have the system knowledge, the components and the project planning competence to help you realize it.
- › You determine and define functionality – we provide possible solutions
- › We combine local and central value-added shares in order to meet the highest requirements with regard to function safety, reliability and cost effectiveness.
- › Our Applications Team, together with a given local entity and the development manager of the customer, supports projects from initial inquiry up to the start of series production. We maintain and observe highest internal standards in the processing of international projects in global core markets thanks to competent local contact persons and applications experts in our applications center.

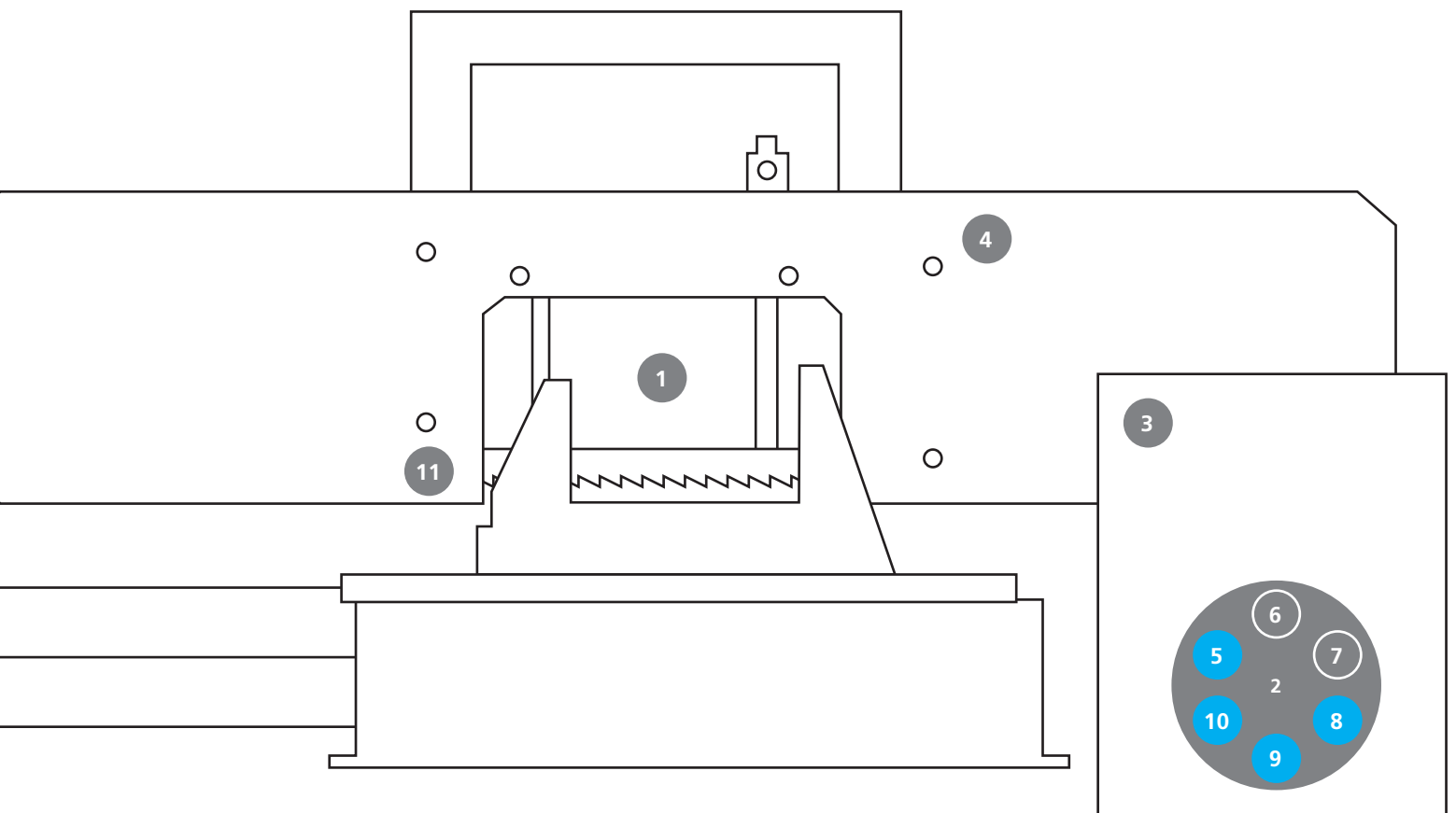

- Working hydraulics
- Filtration

CONDITION MONITORING



OPCom
Oil particle monitor



OPCom FerroS
Wear sensor



LubCos H₂O+ II
Oil condition sensor

OIL SERVICE UNITS for service or retro-fitting



FA Oil service unit

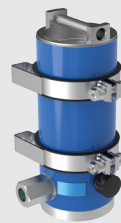

FNS Off-line filter



FNA Off-line filter unit

FILTER ELEMENTS

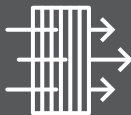

Replacement filter element
EXAPOR®MAX 3

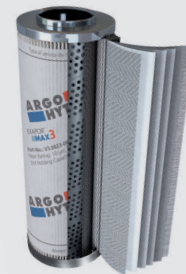

Multilayer structure
EXAPOR®MAX 3

Filter INFO

Spare filter elements by ARGO-HYTOS

- › Lowest pressure loss
- › Excellent dirt holding capacity for long maintenance intervals
- › Avoidance of damage and downtime
- › Reduced maintenance and total cost of ownership (TCO)
- › Optimum protection of your machine's valuable components

The current generation of EXAPOR®MAX 3 elements guarantees maximum filter performance. By using filter layers with a gradient structure, we ensure a very low pressure drop in combination with a high dirt holding capacity. The layers are supported and protected by a patented hybrid fabric, which guarantees optimum in- and outflow. The protective cover is used for identification as an original spare part. It is flexible and can be individually printed, which significantly increases the recognition value.

Of course, ARGO-HYTOS also offers solutions for upgrading housings from other manufacturers with EXAPOR®MAX 3 technology.

Consulting, development, production and maintenance – all under one roof

Commitment – We're here for you!

As an owner-managed, medium-sized family company with over 1000 employees worldwide, ARGO-HYTOS has been serving its customers for over 75 years. With production companies in Germany, the Czech Republic, Poland, China and India as well as numerous own distribution and assembly companies, we are able to offer our customers local support, providing them with reliable contacts.

We are the right partner for your project! Our development and manufacturing expertise allows us to accompany a product throughout the process of its creation. From the conceptual phase to the individualized system solution, we work closely with our customers every step of the way.

For decades, ARGO-HYTOS has developed a relationship with its customers based on trust and continually strives to surpass their needs and expectations, validating the trust placed in us through quality and reliability.

Innovation, competence, quality

We possess extensive development know-how based on the latest manufacturing technologies. We provide all products and process chains under one roof and support our customers in component integration, the development of new and innovative solutions as well as in the optimization of existing systems.

Global presence – Customer satisfaction always and everywhere

ARGO-HYTOS is globally represented with numerous own sales companies. In addition, we collaborate with a network of skilled sales and service partners in all important core markets, ensuring proximity to the customer and a local presence. Our global network of specialists means that you always have a reliable partner at your side. This allows us to provide our customers with the best possible support – from the concept phase up to after-sales service!

International

ARGO-HYTOS worldwide

Benelux	ARGO-HYTOS B.V.	info.benelux@argo-hytos.com
Brazil	ARGO-HYTOS Fluid Power Systems Ltda.	info.br@argo-hytos.com
China	ARGO-HYTOS Fluid Power Systems	info.cn@argo-hytos.com
Germany	ARGO-HYTOS GMBH	info.de@argo-hytos.com
France	ARGO-HYTOS SAS	info.fr@argo-hytos.com
Great Britain	ARGO-HYTOS Ltd.	info.uk@argo-hytos.com
Hong Kong	ARGO-HYTOS Hong Kong Ltd.	info.hk@argo-hytos.com
India	ARGO-HYTOS PVT. LTD.	info.in@argo-hytos.com
Italy	ARGO-HYTOS S.r.l.	info.it@argo-hytos.com
Poland	ARGO-HYTOS Polska spz. o.o.	info.pl@argo-hytos.com
Sweden	ARGO-HYTOS Nordic AB	info.se@argo-hytos.com
Czech Republic	ARGO-HYTOS s.r.o ARGO-HYTOS Protech s.r.o	info.cz@argo-hytos.com info.protech@argo-hytos.com
Turkey	ARGO-HYTOS Hidrolik Ekip. San. ve Tic. Ltd. Şti.	info.tr@argo-hytos.com
USA	ARGO-HYTOS Inc.	info.us@argo-hytos.com

You can find further sales partners worldwide online at www.argo-hytos.com