

EVERYTHING HYDRAULIC
BEYOND EXPECTATIONS

ARGO
HYTOS
A Voith Company



RST-308 RETURN-SUCTION FILTER

Proven quality in a new dimension

In machines with a hydrostatic drive and combined working hydraulic system, the new RST-308 Return-Suction filter series replaces the suction or pressure filters alternatively required for the feed pump of the closed-loop hydrostatic drive circuit as well as the return filter for the open-loop working hydraulic circuit.

This ensures the performance of your system - at significantly reduced costs.

argo-hytos.com

This product is ideal for the following applications:



R S T - 3 0 8

Simple and quick connection

Benefits

- **Smart connection concept:** Line connection directly to the filter in just a few simple steps - quick and easy.
- **Reduced costs:** The use of a return-suction filter saves approx. 40% on purchase and spare parts costs compared to conventional filter concepts.
- **Excellent cold start conditions:** Optimum supply to the filling pump minimizes the risk of cavitation, thus avoiding downtime.

Reliability and maximum performance

The filter bowl of the new RST-308 filter series is made of reinforced plastic, providing an optimum, lightweight solution that withstands the demands of harsh working environments.

Star-pleated EXAPOR®MAX3 filter elements ensure excellent differential pressure stability and dirt holding capacity and thus ensure an above-average filter service life.

The filter head offers various connection options. If required, up to six lines of different sizes can be connected.

Smart connection concept

In contrast to many other filters, the flange head of the hose line can be mounted directly on the filter. Split flanges are no longer necessary. Installation is carried out with just four M8 screws.

This not only simplifies installation and maintenance, but also saves time and money!

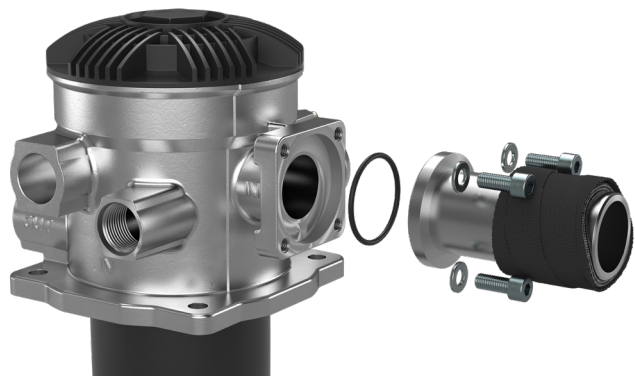

Learn more here:



Datasheet