

## Filter Unit Ecoline

UM 045 / UMP 045



### Safety and operating instructions

Read safety and operating instructions before use.

**Note:** Illustrations do not always correspond exactly to the original. No legal claims come into being due to information provided in error. Subject to design changes.

© All rights are reserved by ARGO-HYTOS GMBH, even in the event of industrial property rights. Any right of disposal such as copying and distribution rights shall remain with us.

The picture on the title page shows a configuration example.  
The delivered product may thus differ from the illustration.

# Contents

Contents .....	2
<b>1. Intended purpose .....</b>	<b>4</b>
1.1 Scope of use.....	4
1.2 With UMP 045 .....	4
1.3 Keeping to the permitted operating conditions.....	4
1.4 Reasonably foreseeable misuse .....	4
<b>2. Safety notes and commissioning .....</b>	<b>5</b>
2.1 General references.....	5
2.2 Meaning of operating instruction symbols .....	5
2.3 Required staff qualification .....	5
2.4 Contents of delivery UM 045 .....	5
2.5 Contents of delivery UMP 045 .....	5
2.6 Do not use or store the device .....	6
2.7 Transport.....	6
2.8 Mains connection.....	6
2.9 Essential points to note before commissioning the filter unit .....	6
2.10 With UMP 045: Installation of the particle counter PODS pro .....	7
2.11 On start up check .....	8
2.12 If there is an unexpected power failure, it is essential to note these points .....	8
<b>3. Dimensions of the device.....</b>	<b>9</b>
<b>4. How to operate the filter unit.....</b>	<b>10</b>
4.1 Filtering hydraulic fluids in the by-pass flow (note safety instructions) .....	10
4.2 Filtering of hydraulic fluids while filling machinery and plant .....	11
4.3 Pumping of hydraulic fluids (e. g. waste oil, filter is by passed).....	11
4.4 To achieve the maximum cleaning performance.....	11
<b>5. Technical data .....</b>	<b>12</b>
5.1 Device data .....	12
<b>6. Operating conditions .....</b>	<b>13</b>
<b>7. Shutdown and disposal .....</b>	<b>14</b>
<b>8. Maintaining the filter unit.....</b>	<b>15</b>
8.1 Maintenance survey.....	15
8.2 Replacing the filter element .....	15
8.3 Checking / changing of the suction strainer (protective strainer for the pump) .....	16
<b>9. Faultfinding / troubleshooting.....</b>	<b>18</b>
<b>10. Appendix.....</b>	<b>20</b>
10.1 EU- Declaration of Conformity.....	20



## 1. Intended purpose

### 1.1 Scope of use

- › To filter hydraulic fluid in the 'by-pass flow' on machinery and plant, taking account of the technical data (see page 12).
- › To filter hydraulic fluids while filling machinery and plant, taking account of the technical data (see page 12).
- › To transfer hydraulic fluids (e. g. waste oil, filter element is by passed) taking account of the technical data (see page 12).

### 1.2 With UMP 045

- › To monitor the oil cleanliness in the "by-pass flow" while filling machinery and plant.
- › To switch off when the defined oil cleanliness has been reached.

### 1.3 Keeping to the permitted operating conditions

The permitted operating conditions must be mandatorily observed (see page 13).

### 1.4 Reasonably foreseeable misuse

The conveying of the following media is prohibited:

- › High flammable fluids, such as petrol or thinners (explosion hazard).
- › Food
- › The device is not suitable for extracting oil sludge and residues.



**DANGER**



- › The manufacturer assumes no liability in the event of improper use or if any modifications are made to the device.

## 2. Safety notes and commissioning

### 2.1 General references

- › If oil has leaked out for any reason, immediately close off the oil covered area and cover it with an oil-binding medium (danger of slipping / skidding).
- › When using hydraulic or lubricating oils of low conductivity, there is a risk of static charging. Consult the manufacturer in this case.
- › With UMP 045: The measuring values of the first 5 minutes should not be considered as the particle counter initializes and the hydraulic circuit must stabilize (air bubbles, flushing etc.).

### 2.2 Meaning of operating instruction symbols

Warning sign, signal word	Meaning
 <b>DANGER</b>	This symbol refers to dangers that could be major or even result in death to individuals.
 <b>WARNING</b>	This symbol refers to dangers to machines, materials and the environment.
 <b>CAUTION</b>	This symbol refers to dangers that are slight to individuals.
<b>NOTE</b>	This symbol indicates information for better understanding / use of the machine's functions.





Sign	Meaning
	This symbol stipulates the wearing of safety gloves.
	This symbol stipulates the wearing of safety shoes.
	This symbol stipulates the wearing of protective goggles.
	This symbol stipulates the disconnection of the device from the power supply.

Table 1: Meaning of signs

The text next to the symbols has to be read thoroughly. The symbols used in each case do not replace the security advice.

### 2.3 Required staff qualification

The device may be operated by the following individuals:

- › Persons who have read and understood these operating instructions.
- › Persons who have been instructed by trained staff.
- › Qualified / specialized staff with adequate training.

The device may be repaired or maintained by the following individuals:

- › Qualified / specialized staff with adequate training.
- › Work on electrical components: Only electrical specialists with adequate training.

### 2.4 Contents of delivery UM 045

- › Filter Unit UM 045
- › Operating Instructions

### 2.5 Contents of delivery UMP 045

- › Filter Unit UMP 045
- › Operating Instructions
- › Optional: Data cable & Software-CD



## WARNING



- › The operating instructions must remain with the filter unit UM 045 / UMP 045 throughout the life time of the unit and be available at all times, even though the unit may change hands.

### 2.6 Do not use or store the device

- › In rain or in a damp or wet environment.
- › Near flammable liquids or gasses.

### 2.7 Transport



- › Wear safety shoes and safety gloves

- › During transport, fix the suction and pressure hoses in the holders provided on the frame to prevent the loss of residual oil from hoses.
- › If mobile transporting aids are used, make sure that the unit is stable (tilting danger).
- › Do not use stairways or higher pitches
- › When situating the unit, look out for a secure position (tilting danger).
- › Only lift by crane and approved belts or ropes (empty weight of the unit: UM 045 ca.75 kg or UMP 045 ca. 82 kg resp.).

### 2.8 Mains connection

- › The mains voltage must always match the voltage shown on the nameplate (motor).
- › The direction of rotation of the motor must match the direction of rotation arrow on the motor housing (check this point every time you switch on the unit) (only with 3-phase motor).
- › The power source must be suitable and correctly protected by fuses (see page 13).
- › Line cross-sections must be adequately dimensioned.
- › The cable and connection for power supply must be in perfect condition.

### 2.9 Essential points to note before commissioning the filter unit

- › The operating conditions must be strictly observed.
- › The operating instructions have to be read thoroughly.
- › The unit must be positioned securely enough and must be free of vibrations (stability, tilting danger).
- › Cables and hoses must not be placed in areas where operating staff move around (danger of tripping over).
- › When using the hoses during unsupervised operation, make sure that they cannot fall out of the tank.
- › The suction and delivery pipes must be immersed far enough under the fluid level so that no air can be sucked in (suction of air can lead to malfunction).
- › If no air is drawn in during the start-up procedure, open the filter housing cover and pour in about 0.5 liters of oil.
- › The oil must be compatible with the hydraulic fluid from previous filtrations. If not, the filter unit must be cleaned and the filter element must be changed.
- › The cover of the filter housing must be correctly sealed. If necessary, screw in the cover manually as far as the limit stop. A gap between the cover and the housing may remain visible.
- › With UMP 045: The hydraulic fluid must be free from water (no oil clouding →measuring values can be adulterated by free water in the oil).

## 2.10 With UMP 045: Installation of the particle counter PODS pro



### WARNING



- › Do not operate the particle counter without return hose. The tank of the particle counter holds a return flow capacity of max. 8 measurements.
- › Danger to the environment by spilling oil.

- › Disassemble the return flow tank and the hose (item 2) as well as the bottle adapter (item 3) from the particle counter (item 1) (see illustration 1).

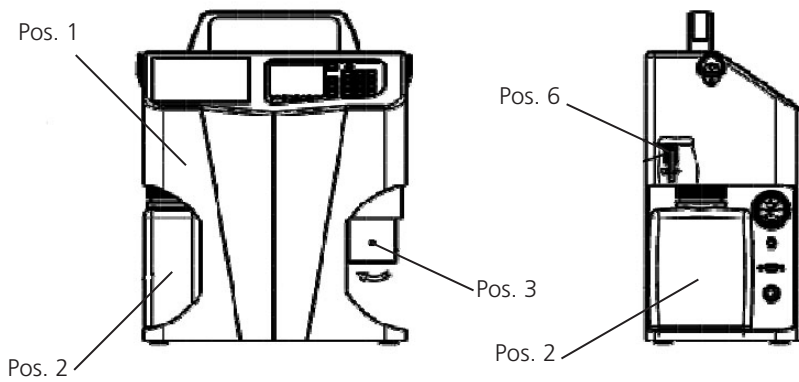

Illustration 1: PODS pro-view 1

- › Attach the provided adapter (item 4) to the particle counter (item 1) and connect the return hose (item 5) to the return connection (item 6) of the particle counter (see illustration 2).
- › Connect the provided data cable to the particle counter (see illustration 2).
- › Connection 1: Plug for electric power supply
- › Connection 2: Plug for data transfer

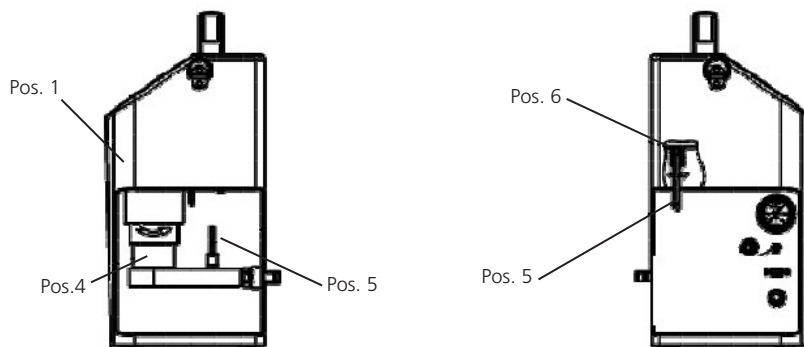

Illustration 2: PODS pro-view 2

- › Attach the particle counter (item 1) by pressing down to the equipment rack (item 7). The fixing bracket (item 8) catches the article counter (see illustration 3).

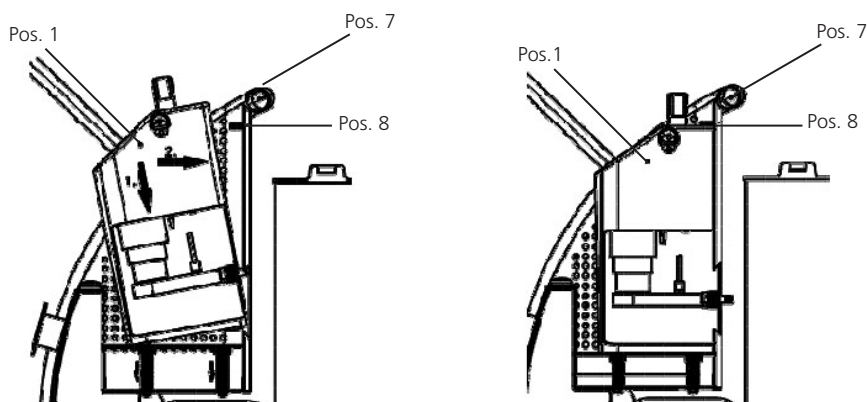

Illustration 3: PODS pro - view 3

- › Connect the suction and return hose (DN 6, black color) to the quick fitting couplings (item 9 and item 10) at the adapter (item 4) (see illustration 4)

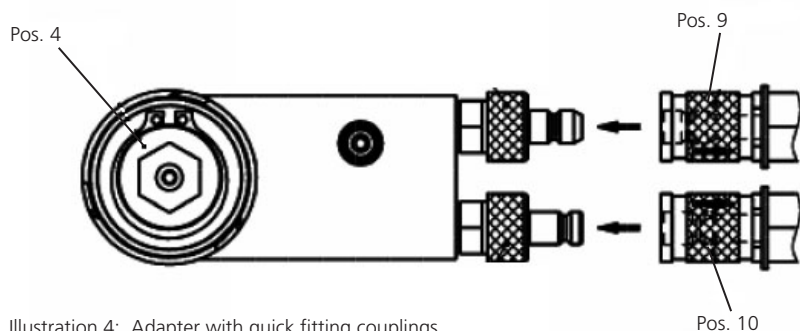

Illustration 4: Adapter with quick fitting couplings

- › Connect the connecting cable to the interface (item 11) of the filter unit (see illustration 5).

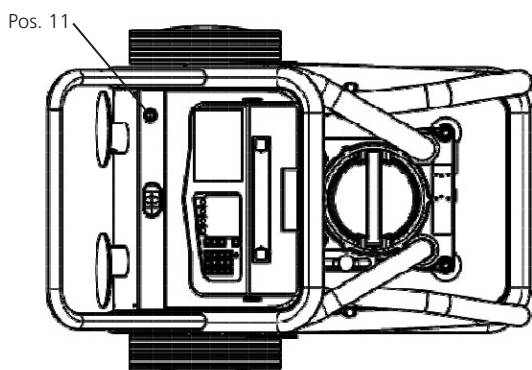

Illustration 5: View of Filter Unit UMP 045

## 2.11 On start up check

- › If the filter unit is tight / sealed.
- › If the direction of rotation of the motor matches the direction of rotation arrow on the motor housing. If not, only allow specialized staff to invert the phases (only with 3-phase motor).
- › De-aeration of the unit: To ventilate the unit automatically, release the black cap at the ventilating valve (see page 9), but do not unscrew it.

By means of manual de-aeration (red cap), the ventilating valve can be checked. With activation, oil must escape within a short time. By this check-up you additionally prevent jamming of the float valve.

## 2.12 If there is an unexpected power failure, it is essential to note these points

- › Switch off the unit or disconnect from the mains supply to prevent the possibility of subsequent damage to the environment and / or people when the power returns.

→ Possible subsequent damage: - oil may overflow  
- danger of slipping on leaked oil



### 3. Dimensions of the device

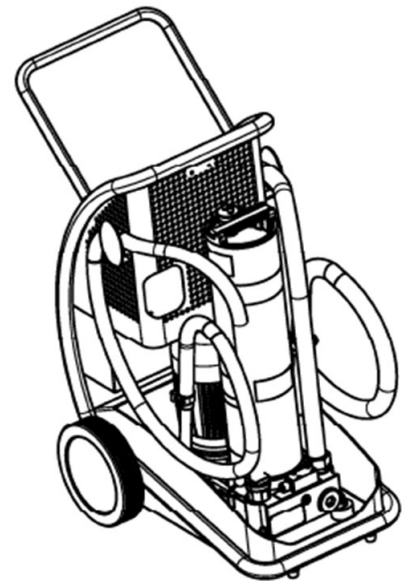
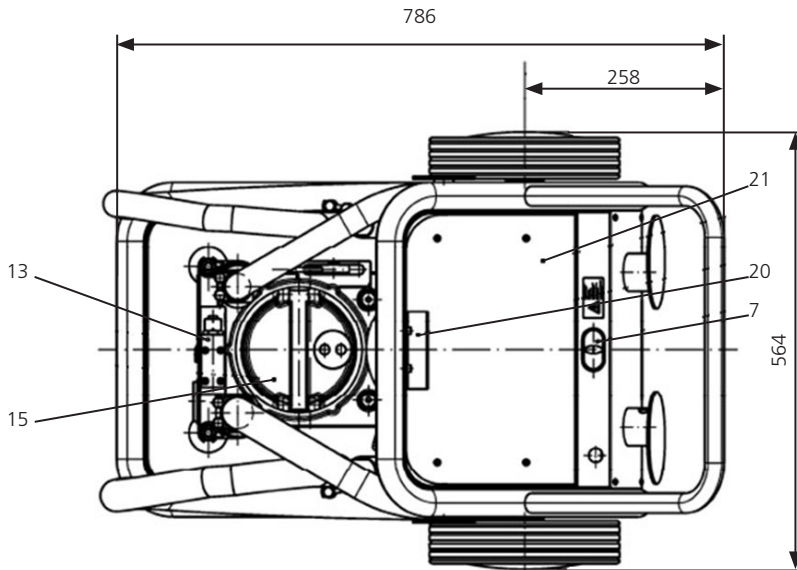
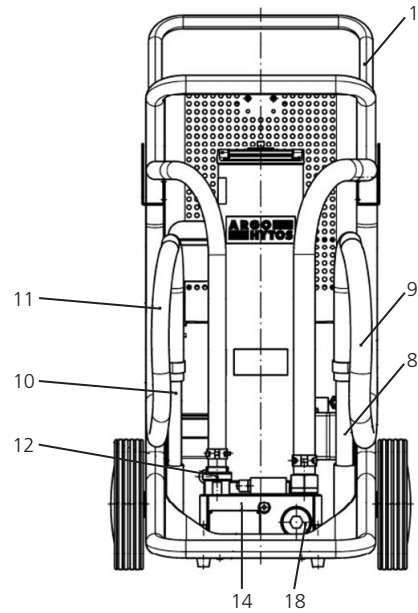
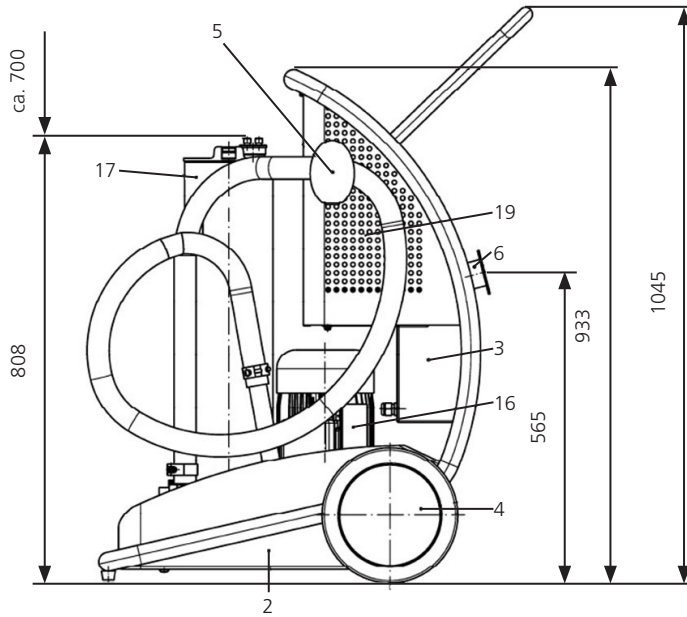

- |    |                              |    |                              |
|----|------------------------------|----|------------------------------|
| 1  | Equipment rack               | 13 | Clogging indicator           |
| 2  | Drip tray                    | 14 | Pump block                   |
| 3  | Electric box / electric unit | 15 | Cover with ventilating valve |
| 4  | Wheel / wheel cap            | 16 | Motor-pump unit              |
| 5  | Hose support                 | 17 | Filter pipe / filter element |
| 6  | Cable holder                 | 18 | Suction strainer             |
| 7  | On-off switch                | 19 | Filing tray                  |
| 8  | Suction pipe                 |    |                              |
| 9  | Suction hose                 |    |                              |
| 10 | Pressure pipe                |    |                              |
| 11 | Pressure hose                | 20 | PODS-fixing bracket          |
| 12 | Rotary valve                 | 21 | Tray for PODS                |

#### With UMP 045

- |    |                     |
|----|---------------------|
| 20 | PODS-fixing bracket |
| 21 | Tray for PODS       |

## 4. How to operate the filter unit



### WARNING



- › The filter unit is equipped with a suction strainer on the suction side, which has to be maintained regularly (see page 9, item 18).
- › A defective or missing suction strainer can lead to pump damage.



- › Wear safety gloves, safety shoes and protective goggles.

### 4.1 Filtering hydraulic fluids in the by-pass flow (note safety instructions)

- › Connect and fix the filter unit as described under point 2 (with 3 phase motors please observe the rotating direction).
- › Immerse the suction pipe and the delivery pipe into the hydraulic tank of the machine or plant.  
**Note:** The distance between intake side and delivery side should be kept apart as far as possible to avoid short-circuit of the oil flow.
- › Switch rotary valve to position II (filtering) (see illustration 6).
- › Switch on the filter unit by using the on-off switch.
- › Check the oil flow (the suction pipe may not be immersed to a sufficient depth in the oil tank).  
**Note:** When starting filtration, filling of the filter unit may take a few seconds.
- › Check the element for clogging, using the clogging indicator.
- › At the end of filtration, switch the rotary valve to position I (pumping). Pull the suction pipe out of the hydraulic tank of the machine or plant and draw in air for max. 30 seconds. Residual oil from the filter unit will be returned via delivery pipe into the hydraulic tank of the machine or plant.
- › Switch off the filter unit by using the on-off switch.

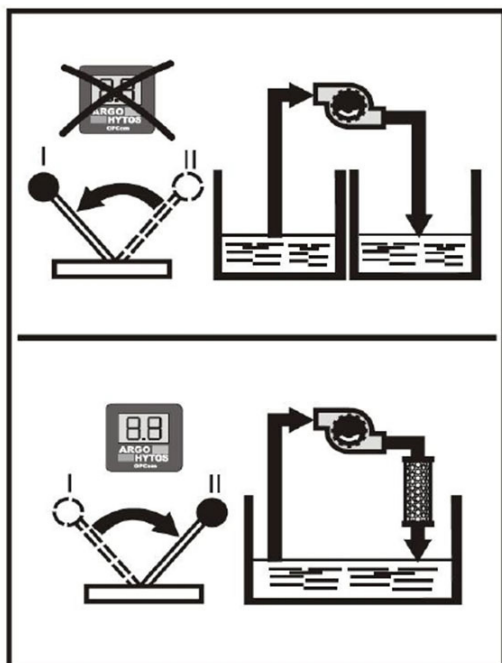

Illustration 6: Switch settings of the rotary valve

## 4.2 Filtering of hydraulic fluids while filling machinery and plant

- › When refilling, make sure that there is no waste oil left in the machine or plant.
- › Connect the filter unit as described under point 2 (with 3 phase motors please observe the rotating direction).
- › Immerse the suction pipe into the oil tank (fresh oil).
- › Immerse the delivery pipe into the hydraulic tank of the machine or plant.
- › Switch rotary valve to position II (filtering).
- › Switch on the filter unit by using the on-off switch.
- › Check the oil flow (the suction pipe may not be immersed to a sufficient depth in the oil tank).  
Note: When starting filtration, filling of the filter unit may take a few seconds.
- › Check the element for clogging, using the clogging indicator.
- › Monitor the filling level of the machine or plant and once the desired filling quantity has been reached, switch off the filter unit by using the on-off switch.

## 4.3 Pumping of hydraulic fluids (e. g. waste oil, filter is by passed)

- › Connect the filter unit as described under point 2 (with 3-phase motors observe rotating direction).
- › Immerse the suction pipe into the hydraulic tank of the machine or plant.
- › Immerse the delivery pipe into an empty container (oil tank).
- › Switch the rotary valve to position I (pumping) (see illustration 6).
- › Switch on the filter unit by using the on-off switch.
- › Check the oil flow (the suction pipe may not be immersed to a sufficient depth in the oil tank).  
Note: When starting filtration, filling of the filter unit may take a few seconds.
- › Monitor the procedure. As soon as the machine / plant has completely been pumped empty, switch off the unit.
- › With UMP 045: Monitor the cleanliness and switch off the filter unit as soon as the defined oil cleanliness has been reached.

### NOTE



- › The unit must be completely de-aerated.
- › Air bubbles can adulterate the measuring values.



- › The specified media temperatures must be adhered to (see page 13).
- › Incorrect viscosities can adulterate the measure values.

- › Connect and fix the filter unit as described under point 2 (with 3 phase motors please observe the rotating direction).
- › Immerse the suction pipe and the delivery pipe into the hydraulic tank of the machine or plant.  
Note: The distance between intake side and delivery side should be kept apart as far as possible to avoid short-circuit of the oil flow.
- › Switch the rotary valve to position II (filtering), switch off the particle counter.
- › Switch on the filter unit by using the on-off switch. Let the unit operate for 3 to 5 minutes to de-aerate the system. Then switch off the UMP 045 again.
- › Program the particle counter to the desired oil cleanliness (see user manual PODS).
- › Consider the switching on sequence by all means (disregarding can lead to mal-functioning):
  1. Start the counting process by pressing the start-button at the particle counter.
  2. Switch on the UMP 045 by using the on-off switch.
  3. Make sure that the rotary valve is turned to position II (filtering).
  4. Control on the display of the particle counter (counting begins after ca. 3 – 5 sec.).
- › The filter unit UMP 045 automatically turns off once the pre-set cleanliness class has been reached.

## 4.4 To achieve the maximum cleaning performance

- › The hydraulic or lubricating system should be operated (recirculation of fluid, low viscosity).
- › The distance between intake side and delivery side should be kept apart as far as possible to avoid short-circuit of the oil flow.
- › Adhere to the appropriate filtration time (recommended level: 20 minutes per 100 l tank volume).

## 5. Technical data

### 5.1 Device data

Nominal flow rate	45 l/min (50 Hz) or 54 l/min (60 Hz) resp.	
Pressure limiting valve	6 ±0,5 bar	
Max. operating pressure	7 bar	
Filter element	V7.1560-103	$\beta_{3(c)} \geq 200$
optional	V7.1560-06	$\beta_{12(c)} \geq 200$
optional	V7.1560-03	$\beta_{5(c)} \geq 200$
optional	Y7.1560-05	$\beta_{8(c)} \geq 200$
	(water absorption capacity ca. 1,5 liters)	

#### NOTE



- › With use of water absorbing elements, particle counting is not possible.
- › Water in oil can adulterate the measuring results.

Clogging indicator (all types)	optical clogging indication DG 042-04 $\Delta p = 3,5 \pm 0,5$ bar
Suction side	G 1 ¼" connection with hose DN 32 and suction pipe (when replacing the suction hose, only use a spiral hose)
Pressure side	G 1" connection with suction hose DN 25 and pressure pipe
Suction strainer	screen element 280 µm
Electrical drive for type UM(P) 045-1153 UM(P) 045-1553 UM(P) 045-1656	1~ AC-motor with operating capacitor 230 V / 50 Hz; 1,1 kW; n= 1500 min BG 90
UM(P) 045-4153 UM(P) 045-4553 UM(P) 045-4656	3~ three-phase-motor 400 / 460 V - 50 / 60 Hz; 1,1 kW; n = 1500 / 1800 min <sup>-1</sup> BG 90
Weight when empty	UM 45 ca. 75 kg / UMP 045 ca. 82 kg
Noise intensity level	max. 73 dB(A) under operating cond. allowed for cont. operation max. 78 dB(A) under operating cond. allowed for short-term op
Dimensions	786 x 564 x 1045 (l x b x h)

## 6. Operating conditions

▶ Permitted temperature range	
for pressurized fluid	0 °C bis 65 °C
ambient	0 °C bis 50 °C



	<ul style="list-style-type: none"> <li>▶ Contact temperatures according to DIN EN 563 (3) and DIN EN 13202 (4) at the filter unit may be exceeded.</li> <li>▶ Burning hazard</li> </ul>
--	-----------------------------------------------------------------------------------------------------------------------------------------------------------------------------------------

▶ Viscosity	Viscosities are always dependent on the fluid temperature
-------------	-----------------------------------------------------------

Electrical drive	Continuous operation min.	Continuous operation max.	Short-term operation max.
1 ~ 230 V	15 mm <sup>2</sup> /s	600 mm <sup>2</sup> /s	800 mm <sup>2</sup> /s
3 ~ 400 V	15 mm <sup>2</sup> /s	600 mm <sup>2</sup> /s	800 mm <sup>2</sup> /s

▶ Permitted suction heights	max. 2,0 m unfilled max. 6 m in operating condition
▶ Resistance to media	Environment-friendly, mineral-oil-based fluids. Please consult the manufacturer if synthetic fluids are used.
▶ Mains connection	
UM(P) 045-1153 UM(P) 045-1553 UM(P) 045-1656 UM(P) 045-8553	230 V - 50 / 60 Hz 16 Ampere
UM(P) 045-4153 UM(P) 045-4553 UM(P) 045-4656	400 / 460 V - 50 / 60 Hz 16 Ampere
▶ Position	vertical



**DANGER**



- › Disconnect the unit from the mains supply before starting any disassembly work. Disassembly work on electrical components has to be carried out strictly by qualified electricians.
- › Danger of electrical shock



- › Disassembly work on the filter unit has to be carried out exclusively by qualified specialists.
- › Danger of injuries of any kind.

The final shutdown and disposal requires complex disassembly of the complete power supply, mechanical components and the disposal of the hydraulic media which remain in the device.

With disassembly and disposal all safety and environmental aspects have to be adhered to.

## 8. Maintaining the filter unit



- › Disconnect the mains plug during maintenance work.
- › Danger of electric shock.



- › Wear safety gloves, safety shoes and protective goggles.

Apart from the filter element (see page 9, item 17) , the suction strainer (see page 9, item 18) and the protection strainer of the particle counter, the filter unit requires no maintenance.

### 8.1 Maintenance survey

Maintenance work	Order-no.	Maintenance intervals
Checking / replacing the filter element	V7.1560-103 (3 µm) V7.1560-03 (5 µm) V7.1560-06 (12 µm)	› As soon as the clogging indicator turns into the red area within the permitted viscosity range.
Checking / replacing the suction strainer	S9.0417-13	› quarterly or › with corresponding peculiarities (lower volume rate with clean filter element, too loud operating noise)

### 8.2 Replacing the filter element

When changing the filter element please proceed as follows (also see illustration 7 and 8):

#### Before changing the filter element

- › Switch the rotary valve to position I (pumping), Pull the suction pipe out of the hydraulic tank of the machine or plant and draw in air for max. 30 seconds. Residual oil from the filter unit will be returned via the delivery pipe into the hydraulic tank of the machine or plant.
- › Switch off the device and disconnect from the mains supply.
- › Let the device cool down if necessary.

#### Disassembly of the filter element

- › Unscrew the housing cover
- › Carefully pull the filter element together with the cover out of the housing (filter element is attached to the cover, allow escaping oil to drip down into the housing).
- › Detach the filter element from the cover by moving it as shown in illustration 7.
- › Dispose of the filter element in line with environmental requirements, waste code: OILFILTER 16 01 07

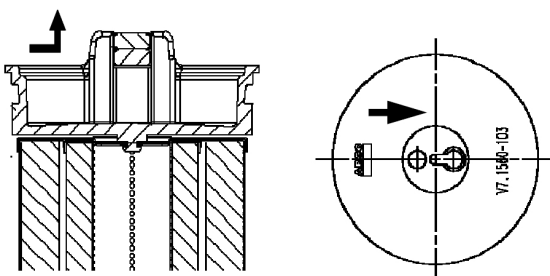

Illustration 7: Releasing the fixture at the cover / filter element

## Installing the filter element

- › Always replace the O-ring on the cover when changing the filter element (part of scope of delivery).
- › Check the type number of the filter element: Compare the numbers of the laser inscription on the filter element, the nameplate or in the operating instructions (see page 12).
- › Attach the filter element to the cover (as shown in illustration 8).
- › Carefully insert the cover with the filter element into the filter housing.
- › Screw in the cover manually as far as the limit stop (a gap between cover and housing may remain visible).
- › Check that the ventilation slits of the electrical motor are not clogged with dirt. Remove deposits, if necessary.
- › Restart the device.
- › Check the tightness of the filter housing after starting operation.

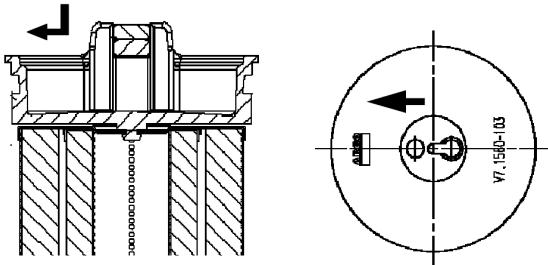

Illustration 8: Attaching the cover to the element

### NOTE



- › Oil which accidentally spilt onto the filter unit when changing the filter element may seem to be leaked oil.

## 8.3 Checking / changing of the suction strainer (protective strainer for the pump)

When changing the suction strainer please proceed as follows (also see illustration 7 and illustration 8):

### Replacing the suction strainer

- › Provide a drip tray for residual oil and the clogged filter element.
- › Unscrew the locking screw (item 1) by hexagon socket screw key SW 22.
- › Slightly pull the clogged element out of the housing.
- › Dispose of the filter element in line with environmental requirements, waste code: OILFILTER 16 01 07

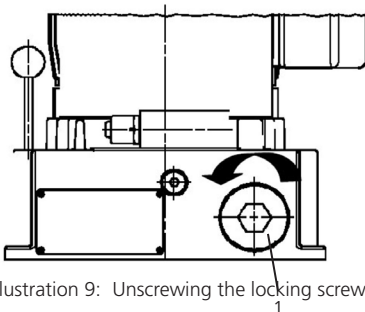

Illustration 9: Unscrewing the locking screw



### Installing the suction strainer

- › Always replace the O-ring when changing the filter element.
- › Attach the suction filter element (item 1) carefully into the pump block.
- › Screw in the locking screw and tighten it by hexagon socket screw key SW 22 (MA 25 ±2,5 Nm).
- › Check the tightness of the locking screw after starting operation and tighten it if necessary.

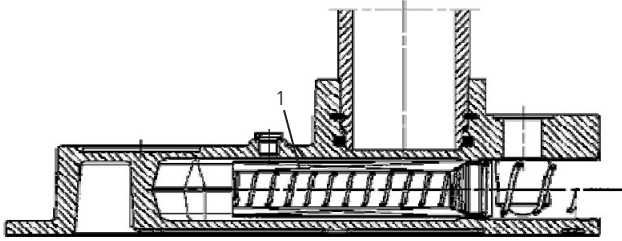

Illustration 10: Installing the suction strainer

#### NOTE



- › Oil which accidentally spilt onto the filter unit when changing the filter element may seem to be leaked oil.

## 9. Faultfinding / troubleshooting

Problem / fault	Possible cause	Remedy
Electric motor will not turn on start up	<ul style="list-style-type: none"> <li>› Electrical cable or plug is faulty</li> <li>› No mains voltage</li> <li>› Motor is faulty</li> <li>› Pump is faulty</li> <li>› Viscosity is too high (medium)</li> </ul>	<ul style="list-style-type: none"> <li>› Have the cable replaced by a specialist</li> <li>› Provide mains voltage, e.g.</li> <li>› Replace / repair the motor (repair at manufacturer's premises)</li> <li>› Replace/ repair the pump (repair at manufacturer's premises)</li> <li>› Heat the medium</li> </ul>
Electrical motor switches off during operation	<ul style="list-style-type: none"> <li>› Electric motor has overheated</li> <li>› Pump is blocked</li> </ul>	<ul style="list-style-type: none"> <li>› Let the motor cool down, clean the ventilation slits if they are clogged</li> <li>› Replace / repair the pump (repair at manufacturer's premises)</li> </ul>
Volume flow rate is clearly too low	<ul style="list-style-type: none"> <li>› Filter element is clogged</li> <li>› Suction strainer is clogged</li> <li>› Viscosity is too high</li> <li>› Suction height is too great</li> <li>› Leak on suction side</li> <li>› Pump is worn</li> </ul>	<ul style="list-style-type: none"> <li>› Replace the filter element</li> <li>› Replace the suction strainer</li> <li>› Heat the medium</li> <li>› Adjust the suction height</li> <li>› Replace the suction hose or seal the connection points (tighten them)</li> <li>› Replace the pump (repair at manufacturer's premises)</li> </ul>
Operating noise is too loud	<ul style="list-style-type: none"> <li>› Filter element is clogged</li> <li>› Suction strainer is clogged</li> <li>› Viscosity is too high</li> <li>› Suction height is too great</li> <li>› Leak on suction side</li> <li>› Filter unit is standing on vibration-sensitive surface (e.g. metal sheet)</li> </ul>	<ul style="list-style-type: none"> <li>› Replace the filter element</li> <li>› Replace the suction strainer</li> <li>› Heat the medium</li> <li>› Adjust the suction height</li> <li>› Replace the suction hose or seal the connection points (tighten them)</li> <li>› Improve conditions of location</li> </ul>
Pump does not draw in fluid	<ul style="list-style-type: none"> <li>› Leak on suction side</li> <li>› Sealing plug of the suction strainer is leaky</li> <li>› Unit is running dry (with new filling)</li> </ul>	<ul style="list-style-type: none"> <li>› Replace the suction hose or seal the connection points (tighten them)</li> <li>› Check the sealing ring and replace it if necessary, check tightening torque</li> <li>› Prime unit (with 0,5l to 3l)</li> </ul>
Particle counter (PODS) does not start the pre-set program	<ul style="list-style-type: none"> <li>› Inlet pressure at the PODS is too low or missing</li> <li>› The switching on sequence has not been considered</li> <li>› Wiring between PODS und UMP 045 is faulty, no data transfer</li> </ul>	<ul style="list-style-type: none"> <li>› Pressure or return hose at the plug-in adapter is loose.</li> <li>› Consider the switching on sequence</li> <li>› Set up the electrical connection</li> </ul>
UMP 045 does not switch off once the pre-set cleanliness class has been reached.	<ul style="list-style-type: none"> <li>› Wrong mode has been adjusted when programming the particle counter. No output signal at the UMP 045</li> <li>› Wiring between PODS und UMP 045 is faulty, no data transfer</li> </ul>	<ul style="list-style-type: none"> <li>› Switch over to the filtering mode when programming the particle counter. Consider the operating instructions of the particle counter.</li> <li>› Set up the electrical connection</li> </ul>

 **DANGER**



- › Only allow specialized staff to carry out electrical repair work.
- › Danger of electric shock

 **WARNING**



- › Maintenance work has to be carried out with special care. All parts that come into contact with the hydraulic medium must be kept free of dirt.
- › If dirt enters the pump during maintenance work, optimal function of the filter unit is no longer guaranteed. In this case the manufacturer assumes no liability.

**EU - Konformitätserklärung**  
EU - Declaration of Conformity



**ARGO-HYTOS Polska sp. z o.o.**  
Władysława Grabskiego 27  
32-640 Zator

Tel.: +48 33 873 16 52  
Fax: +48 33 873 19 15  
www.argo-hytos.com

Die EU - Konformitätserklärung gilt für folgendes  
Gerät:

Filteraggregat

The EU - Declaration of Conformity applies  
to the following unit:

Filter Unit

**UMP 045 / UM 045**

Wir bestätigen die Übereinstimmung mit den  
wesentlichen Anforderungen der europäischen  
Richtlinie(n):

**Maschinenrichtlinie 2006/42-EG**

**EMV Richtlinie 2004/108/EG**

We confirm the conformity according to the  
essential requirements of the European  
directive(s):

**Machinery Directive 2006/42/EC**

**EMC Directive 2004/108/EC**

Folgende Norm(en) wurde(n) angewandt:

The following standard(s) was (were) applied:

**DIN EN 809**  
**DIN EN 60204-1 (VDE 0113-1: 2007-06)**

Zator, 22.11.2016

(Ort und Datum der  
Ausstellung)

(Place and date of issue)

(Unterschrift ) Arkadiusz Noworyta/  
Vorsitzender des Vorstandes

(Signature) Arkadiusz Noworyta/  
President of the Board

International

## ARGO-HYTOS worldwide

Benelux	ARGO-HYTOS B.V.	info.benelux@argo-hytos.com
Brazil	ARGO-HYTOS Fluid Power Systems Ltda.	info.br@argo-hytos.com
China	ARGO-HYTOS Fluid Power Systems	info.cn@argo-hytos.com
Czech Republic	ARGO-HYTOS s.r.o	info.cz@argo-hytos.com
	ARGO-HYTOS Protech s.r.o	info.protech@argo-hytos.com
France	ARGO-HYTOS SAS	info.fr@argo-hytos.com
Germany	ARGO-HYTOS GMBH	info.de@argo-hytos.com
<b>Great Britain</b>	ARGO-HYTOS Ltd.	info.uk@argo-hytos.com
Hong Kong	ARGO-HYTOS Hong Kong Ltd.	info.hk@argo-hytos.com
<b>India</b>	ARGO-HYTOS PVT. LTD.	info.in@argo-hytos.com
<b>Italy</b>	ARGO-HYTOS S.r.l.	info.it@argo-hytos.com
<b>Poland</b>	ARGO-HYTOS Polska spz o.o.	info.pl@argo-hytos.com
<b>Sweden</b>	ARGO-HYTOS Nordic AB	info.se@argo-hytos.com
<b>Turkey</b>	ARGO-HYTOS Hidrolik Ekip. San. ve Tic. Ltd. Şti.	info.tr@argo-hytos.com
<b>USA</b>	ARGO-HYTOS Inc.	info.us@argo-hytos.com

