

Filter and Recirculating Pump Unit

UMPCL 045 Lightline



41733800 / 03.2021 / EN



Safety and operating instructions

Read safety and operating instructions before use.

Note: The indicated data only serve to describe the product. Specifications regarding the use of this product are only examples and suggestions. Catalog specifications are no guaranteed features. The information given does not release the user from his / her own assessments and inspection.

Our products are subject to a natural wear and aging process.

© All rights are reserved by ARGO-HYTOS, even in the event of industrial property rights. Any right of disposal such as copying and distribution rights shall remain with us.

The picture on the title page shows a configuration example. The delivered product may thus differ from the illustration.

Content

Content	2
1. About this documentation	4
1.1 Applicability of this documentation	4
1.2 Required and supplementary documentation	4
1.3 Presentation of information	4
1.3.1 Safety instructions	4
1.3.2 Symbols	5
1.3.3 Terms	5
1.3.4 Abbreviations	5
2. Safety instructions	6
2.1 About this chapter	6
2.2 Intended use	6
2.3 Improper use	6
2.4 Reasonable foreseeable misuse	6
2.5 Qualification of personnel	6
2.6 General safety instructions	7
2.7 Product and technology related safety instructions	7
3. General instructions	8
4. Scope of delivery	9
5. About this product	10
5.1 Component overview	10
5.2 Operating elements	13
5.3 Identification of the product	14
6. Transport and storage	15
6.1 Transport	15
6.2 Storage	15
7. Assembly	16
8. Commissioning	17
8.1 After switching on	17
8.2 In case of power failure	17
8.3 Venting	17
9. Service	18
9.1 Switching on the device	18
9.2. Data collection	18
10. Operation	19
10.1 Filtering of hydraulic fluids when refilling	20
10.2 Filtering of liquids in the bypass flow	21
10.3 Pumping of hydraulic fluids (e.g. waste oil, filter is bypassed)	22
10.4 Flow adjustment (only available with UMPCL 045A)	22
10.5 Monitoring the oil cleanliness when filling machines and systems	23
10.6 Monitoring the oil cleanliness when cleaning machines and systems in the bypass flow	24

11.	Repair and maintenance	25
11.1	Maintenance overview	25
11.2	Changing the filter element	25
11.3	Removing the filter element	26
11.3.1	Removing the filter element from the cover	26
11.3.2	Attaching the filter element	26
11.3.3	Installing the filter element	27
11.4	Checking / changing the suction filter element (pump protection filter)	27
11.4.1	Removing the suction filter	27
11.4.2	Installing the suction filter.....	27
11.5	Checking / cleaning OPCom protective filters.....	28
12.	Decommissioning	29
13.	Disassembly	30
14.	Disposal	31
14.1	Environmental protection	31
15.	Extension and conversion.....	32
16.	Troubleshooting.....	33
16.1	Basic procedure	33
17.	Technical specifications	35
17.1	Drawing	35
17.2	Technical data	36
17.3	Operating conditions	37
17.4	Hydraulic circuit diagram	37
18.	Appendix.....	38
18.1	Declaration of conformity	38
18.2	Spare parts.....	39

1. About this documentation

1.1 Applicability of the documentation

This documentation is applicable for the following product:

- › Filter and Recirculating Pump Unit UMPCL 045

This documentation is written for technicians, operators, service engineers and system operators.

This document contains important information for safe and appropriate assembly, transport, activation, operation, usage, servicing, dismantling and simple troubleshooting.

- › Read this document completely and in particular Chapter 2, "Safety Instructions", before you work with the product.

1.2 Required and supplementary documentation

Do not commission the product until you have received the documentation marked with the book icon and before you have understood and complied with the information therein.



	Title	Document number	Document type
	Data sheet	8070_EN	
	Safety and operating instructions	OPCom Particle Monitor	Manual

Table 1: Required and supplementary documentation

1.3 Presentation of information

So that this document can help you to work quickly and safely with your product, we use standardized safety instructions, symbols, terms and abbreviations. For better understanding, these are explained in the following sections.

1.3.1 Safety instructions

In this documentation, safety instructions are faced with a sequence of actions which would result in the danger of personal injury or damage to equipment. The measures described to avoid these hazards must be observed.

Safety instructions are as follows:

 SIGNAL WORD	
Type and source of danger	
› Consequences of the danger	
› Escaping or averting the danger	
› Rescue (optional)	

- › Warning signal: draws attention to the danger
- › Signal word: indicates the severity of the danger
- › Type and source of danger: specifies the type and source of the danger
- › Consequences: describes the consequences in the event of non-compliance
- › Action: indicates how the danger can be avoided



Warning sign, signal word	Meaning
 DANGER	Indicates a dangerous situation which results in death or serious injury if not avoided.
 WARNING	Indicates a dangerous situation which may result in death or serious bodily injury if not avoided.
 CAUTION	Indicates a dangerous situation which may result in light to moderate injury if not avoided.
NOTE	Indicates property damage: The product or surrounding could be damaged.

Table 2: Hazard classes according to ANSI Z536.6-2006

1.3.2 Symbols

The following symbols indicate notes which are not safety-relevant but increase the intelligibility of the documentation.









Symbols	Meaning
	If this information is not observed, the product cannot optimally be used or operated.
>	Singular, independent action step / instruction
1. 2. 3.	Numbered instruction The numbers indicate that the action steps follow one another.
	This symbol indicates danger to equipment, material and environment.
	This symbol indicates the risk of personal injury (minor injury).
	This symbol indicates the risk of personal injury (death, serious bodily injury).
	This symbol specifies that protective gloves should be worn.
	This symbol specifies that safety shoes should be worn.
	This symbol specifies that protective goggles should be worn.
	This symbol specifies that the unit should be disconnected from the power supply.

Table 3: Meaning of symbols

1.3.3 Terms

In this documentation the following terms are used:

Term	Meaning

Table 4: Terms

1.3.4 Abbreviations

In this documentation the following abbreviations are used:

Term	Meaning
UMPCL	Pumping unit with condition monitoring

Table 5: Abbreviations

2.1 About this chapter

This product was manufactured according to the generally recognized standards of engineering. Nevertheless, there is a danger of injury or damage if you do not observe this chapter and the safety instructions in this documentation.

- › Read this document thoroughly and completely before working with the product.
- › Retain this document and ensure that it is available for all users at all times.
- › Always include the necessary documentation when passing the equipment along to a third party.

2.2 Intended use

This product is a hydraulic component.

You may use the product for the following:

- › for filtration of hydraulic fluids in the bypass flow on machines and systems, taking account of the technical data.
- › for filtration of hydraulic fluids during filling of machines and plants, taking into account the technical data
- › for pumping of hydraulic fluids (e.g. waste oil, filter element is bypassed), taking into account the technical data
- › for monitoring the oil cleanliness in the bypass flow during cleaning or filling of machines and plants

This product is intended for professional use only and not for private use.

"Intended use" also includes that you have completely read and understood this documentation, in particular Chapter 2 "Safety Instructions".

2.3 Improper use

Any other use than the intended use described, is improper and inadmissible.

If unsuitable products are installed or used in safety-related applications, unintended operating states may occur in the application, which may cause personal injury and / or property damage.

Therefore only use this product in safety-related applications if this use is explicitly specified and permitted in the product documentation, e.g. in explosion protection areas or in safety-related parts of a control system (functional safety).

ARGO-HYTOS assumes no liability for damages resulting from improper use. The risks associated with improper use are solely with the user.

2.4 Reasonable foreseeable misuse

The delivery of the following media is forbidden:

- › others than listed in Chapter 17.3 "Operating conditions"

especially:

- › flammable liquids such as petrol or thinner (explosion hazard)
- › foodstuffs
- › sludge and sediment

The operator alone is liable for damages resulting from improper use.

2.5 Qualification of personnel

The operations described in this document require fundamental knowledge of mechanics and hydraulics as well as knowledge of the appropriate technical terms. In order to ensure safe use, these operations may therefore only be carried out by a correspondingly skilled worker or an instructed person under the guidance of a skilled worker.





A skilled worker is someone who can - based on his / her technical education, knowledge and experience as well as knowledge of the respective regulations of the jobs assigned to him / her - recognize possible dangers and ensure appropriate safety measures.

A skilled worker must observe the relevant technical regulations.

2.6 General safety instructions

- › Observe the valid regulations for accident prevention and environmental protection.
- › Observe the safety regulations and requirements of the country in which the product is used / applied.
- › Only use ARGO-HYTOS products that are in technically perfect condition.
- › Observe all instructions on the product.
- › People who assemble, operate, disassemble or maintain ARGO-HYTOS products may not do so under the influence of alcohol, other drugs or medications that affect the responsiveness.
- › Only use manufacturer-approved accessories and spare parts, in order to prevent personal danger due to unsuitable spare parts.
- › Observe the technical data and ambient specifications specified in the product documentation.
- › If unsuitable products are used or installed in safety-relevant applications, unintended operating states may occur in the application, which can cause personal injury and / or material damage. Therefore only use the product in safety-relevant applications if this use is explicitly specified and permitted in the product documentation.
- › You may only put the product into operation, when it has been established that the final product (e.g. a machine or system), into which the ARGO-HYTOS products have been installed, complies with the country-specific regulations, safety regulations and standards of the application.

2.7 Product and technology related safety instructions

 CAUTION	
	<p>Leaked hydraulic oil Environmental hazard / risk of slipping.</p> <ul style="list-style-type: none">› In case of spills, cover the oil-covered surface immediately with an oil-binding medium.› Then immediately dispose of the oil-binding medium according to the national environmental regulations.
	<p>Ignition hazard Risk of electrostatic charge by poorly conducting hydraulic fluid.</p> <ul style="list-style-type: none">› If the electrical conductivity of the hydraulic fluid is not known, please contact the manufacturer of the hydraulic fluid.
	<p>Risk of burns Contact temperatures according to DIN EN563 (3) and DIN EN13202 (4) may be exceeded during operation.</p> <ul style="list-style-type: none">› Allow the off-line filter unit to cool down before touching it.

For prevention of material damage and product damage



CAUTION



Danger due to improper handling

Property damage

- › The off-line filter unit may only be used in accordance with Section 2.2, "Intended use".

Leakage or spillage of hydraulic fluid

Environmental pollution and ground water contamination.

- › Use oil binding agents in order to bind leaked hydraulic oil.



Risk of burns

Contact temperatures according to DIN EN563 (3) and DIN EN13202 (4) may be exceeded during operation.

- › Allow the off-line filter unit to cool down before touching it.

Contamination due to fluids and foreign bodies

Premature wear, malfunction, risk of damage, property damage.

- › Ensure cleanliness during installation in order to prevent foreign bodies, such as welding beads or metal chips, from entering the hydraulic lines, leading to premature wear or malfunction.
- › Make sure that connections, hydraulic lines and attachment parts (e.g. gauges) are free from dirt and chips.
- › Prior to commissioning, check that all hydraulic and mechanical connections are connected and tight, and that all gaskets and seals of the plug connectors are correctly assembled and undamaged.
- › For removal of lubricants and other contaminants, use residue-free industrial wipes.
- › Make sure that all connections, hydraulic lines and attachment parts are clean.
- › Ensure that no contaminants enter when closing the connections.
- › Make sure that no detergents enter the hydraulic system.
- › Do not use cotton waste or faying cleaning rags for cleaning.
- › Do not use hemp as sealing agent.



Improper cleaning

Premature wear, malfunction, risk of damage, property damage.

- › Close all openings with appropriate protective fittings to prevent penetration of detergents.
- › Do not use aggressive cleaning agents for cleaning. Clean the product with a suitable cleaning fluid.
- › Do not use a high pressure cleaner.
- › Do not use compressed air to clean function interfaces such as seal areas.

4. Scope of delivery

This package includes:

- › 1 Filter and Recirculating Pump Unit UMPCL 045
- › 1 Operating manual

5.1 Component overview

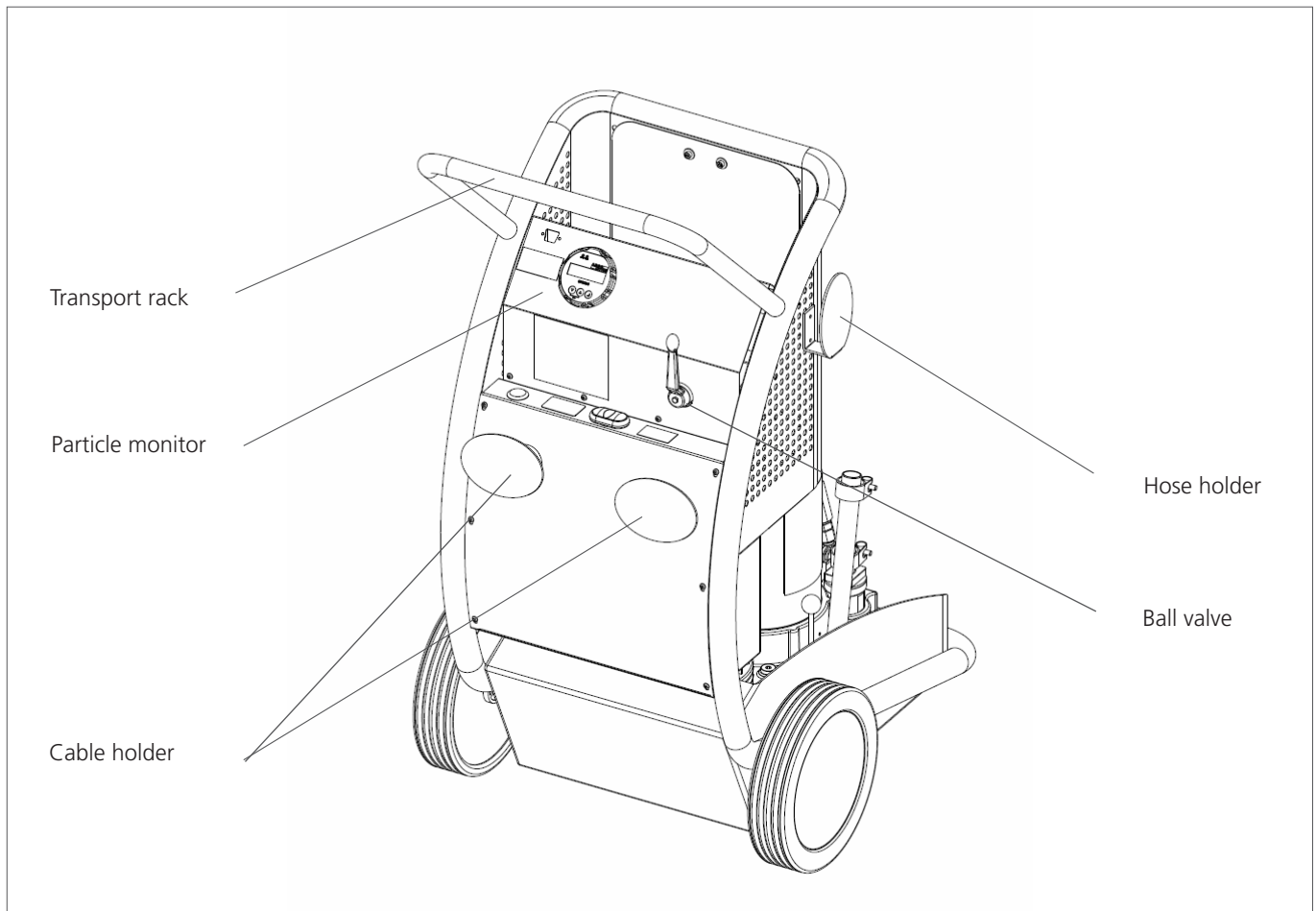

Fig.1: Component overview

Transport rack

The transport rack is equipped with two wheels. This hand truck enables the unit to be transported without difficulty (weight: 88 kg) even to inaccessible / narrow areas.

Particle oil monitor

The particle monitor OPCom allows a particle measurement according to the latest standard. Thus, the level of contamination as well as the trend of the cleanliness of fluids can be observed.

Hose holder

On both sides of the unit there are hose holders on which hoses (suction and pressure hose) can be wound for better transport in case of non-use.

Ball valve

The 3-way ball valve makes it possible to determine whether the oil cleanliness monitoring is to be performed before or after the filter.

Cable holder

On the front of the unit there is a cable holder, on which the 230V or 400V power cable can be wound up for better transport in case of non-use.

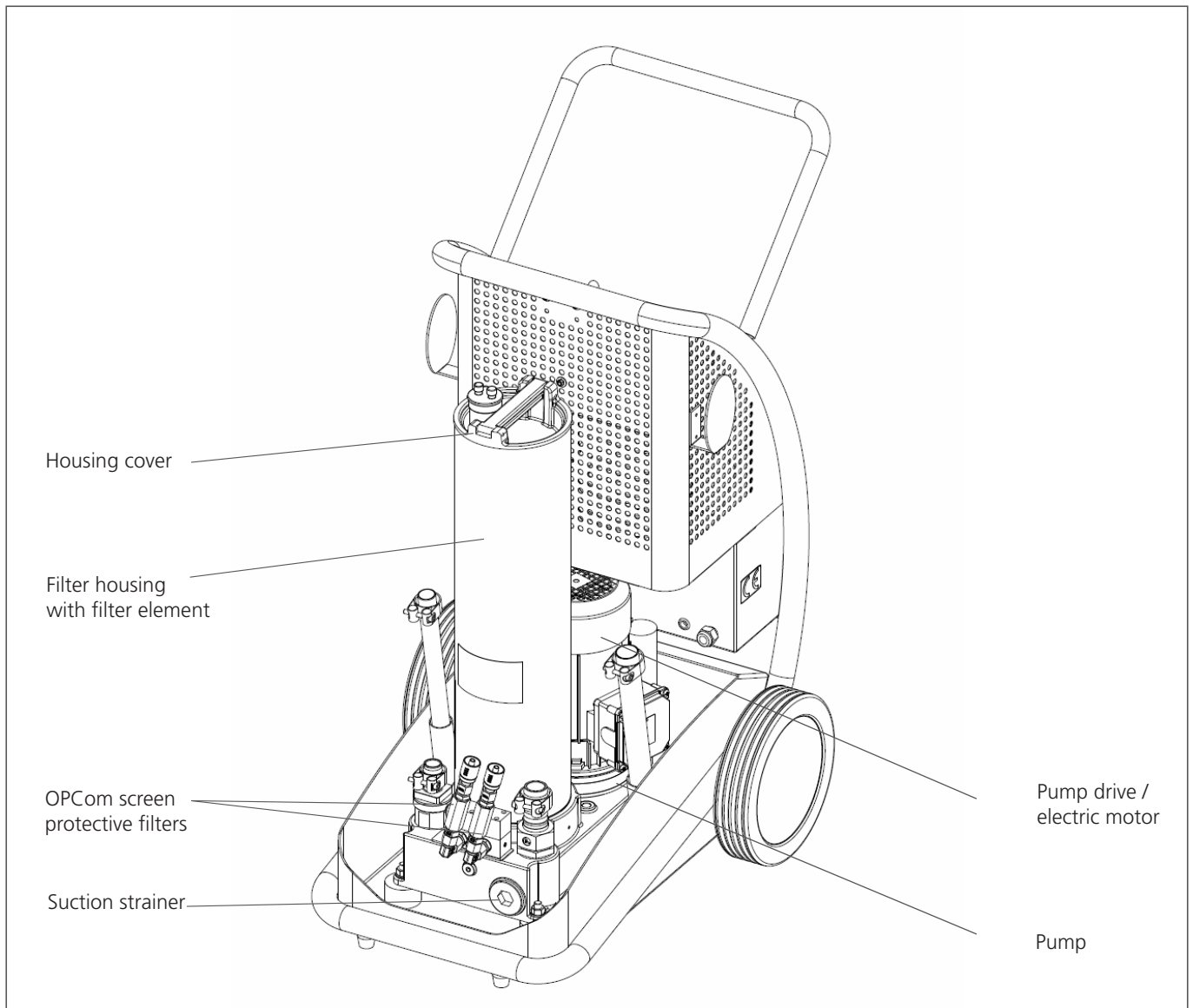

Fig.2: Component overview 2

Housing cover

The housing cover closes the filter housing and serves, inter alia, for venting.

Filter housing with filter element

The filter housing contains the replaceable filter elements.

Changing the filter elements is described in " 11.2 Changing the filter element " on page 25.

Pump / electric motor

The pump unit driven by an electric motor is responsible for media conveyance.

OPCom screen protective filters

The filter unit is provided with screen filters. These elements protect the OPCom particle sensor from dirt which can block the oil flow. Screen filters should be cleaned regularly.

Suction strainer

The filter unit is provided with a protective strainer at the suction side, which has to be serviced regularly.

A missing protective strainer may lead to destruction of the pump. Checking / changing the suction filter is described in " 11.4 Checking / changing the suction filter element (pump protection filter) " on page 27.

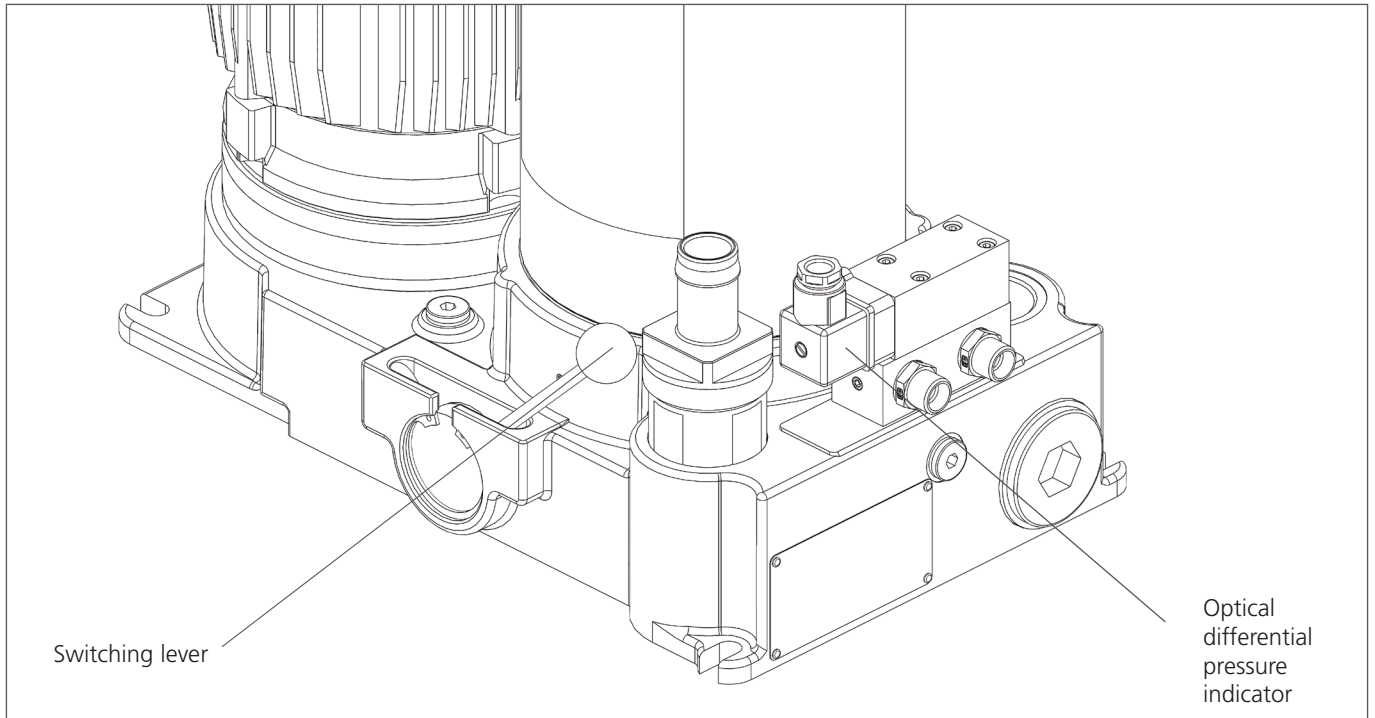

Fig.3: Component overview 3 (transport rack removed)

Switching lever

This lever is used to switch the unit from "pumping" mode to "filtering".

Optical differential pressure indicator

This switch monitors the pressure of the medium before and after the filter. When the preset differential pressure is reached, the optical indicator changes from green to red. If the pressure differential returns to a value below the preset limit, the indicator changes back to green, i.e. no manual reset of the indicator is required.

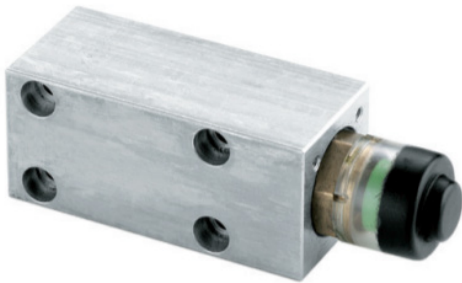

Fig.4: Optical differential pressure indicator

5.2 Operating elements



Fig.5: Operating elements 1

ON / OFF switch

This switch is used to turn the unit on or off when the plug is plugged in.

Particle oil monitor

The particle monitor OPCOM allows a particle measurement according to the latest standard. Thus, the level of contamination as well as the trend of the cleanliness of fluids can be observed. The sensor is equipped with a data memory which internally stores up to 3,000 results. When the memory capacity has been reached, the last measured value is stored and the oldest measured value is overwritten. For more detailed information read the supplementary documentation: OPCOM Particle Monitor - Safety and operating instructions

Connection RS232

In the front panel of the UMPC 045 unit there is a serial interface via which the OPCOM Particle Monitor can be read out and configured.

Safety button (only available in the adjustable flow version)

The purpose of an emergency button is to stop the unit quickly when there is a risk of injury or the workflow must be stopped.

Ball valve

The 3-way ball valve makes it possible to determine whether the oil cleanliness monitoring is to be performed before or after the filter.

Potentiometer (only available in the adjustable flow version)

The potentiometer is used for manual adjustment of the flow rate in the range of 20-70 l/min.

5.3 Identification of the product

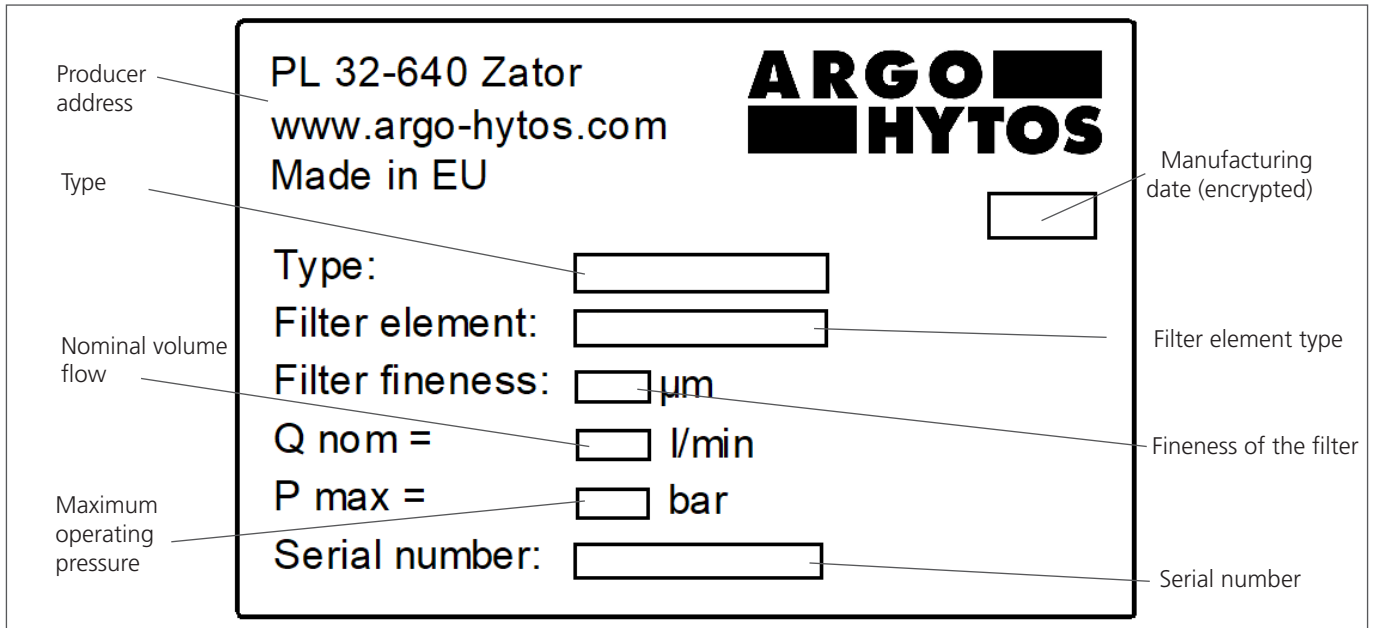

Fig.6: Nameplate

6. Transport and storage

6.1 Transport

The unit should be transported horizontally as there is always a certain amount of oil inside the filter unit (in the filter as well as in the pump), which will leak out during other transport and lead to soiling.

Observe the notes in Chapter 2 "Safety instructions".

Ensure that the unit is in a safe position (tipping hazard).

To prevent the leakage of residual oil, seal hoses at the open connections before transport.

During transport, secure the suction hose and the pressure hose in the brackets provided for this purpose in order to avoid possible leakage of residual oil.

Do not use stair steps or elevated steps.



Fig. 7: Transport rack

The unit is mounted on a transport rack with two wheels.

This hand truck enables the unit to be transported without difficulty (weight: 88 kg) even to inaccessible / narrow areas.

For transport, the unit can be rolled over the wheels by pushing the handle (see arrow) and transported to the destination.

6.2 Storage

The UMPC 045 filter unit should be stored in a confined space to protect it from humidity and condensation.

DANGER



Risk of injury

Danger of chemical reactions

Chemical substances in the immediate vicinity of the filter unit can react and lead to the destruction of the device and to injuries to persons in the immediate vicinity of the device.

- › Storage in the immediate vicinity of chemically active substances such as acids, alkalis, salts, organic solvents and rechargeable batteries is prohibited.

The ambient temperature during storage of the filter unit UMPCL 045 should be between +0 °C and +50 °C at a maximum humidity of 80 %.

Before storage over a period of more than 6 months, the device should be filled with oil in order to preserve it against corrosion.



Risk of functional impairment
Faulty power supply

- › Always consider the country-specific regulations.

Let - prior to commissioning - an electrician check whether:

- › the mains voltage matches with the voltage specified on the type plate of the motor,
- › the power source has appropriately been secured (16 A),
- › the cross-section is of sufficient size,
- › cable and connection to the power source are in perfect condition.

The following steps are to be followed in detail:

- › connect the 230V (or 400V) voltage plug to the local power supply.

8. Commissioning

8.1 After switching on

- › Check the filter unit for leaks.
- › Check that the device is properly vented.

8.2 In case of power failure

In order to prevent unintentional starting of the unit, always switch off and unplug the unit.

8.3 Venting

To bleed the unit automatically, loosen the black cap (3) on the ventilating valve (1).

NOTE



Do NOT unscrew the black cap (3)

The ventilating valve (1) can be checked by means of manual venting (red cap / 2).
After repeated actuation of the valve, oil should escape.
This check also prevents the float valve from being glued.

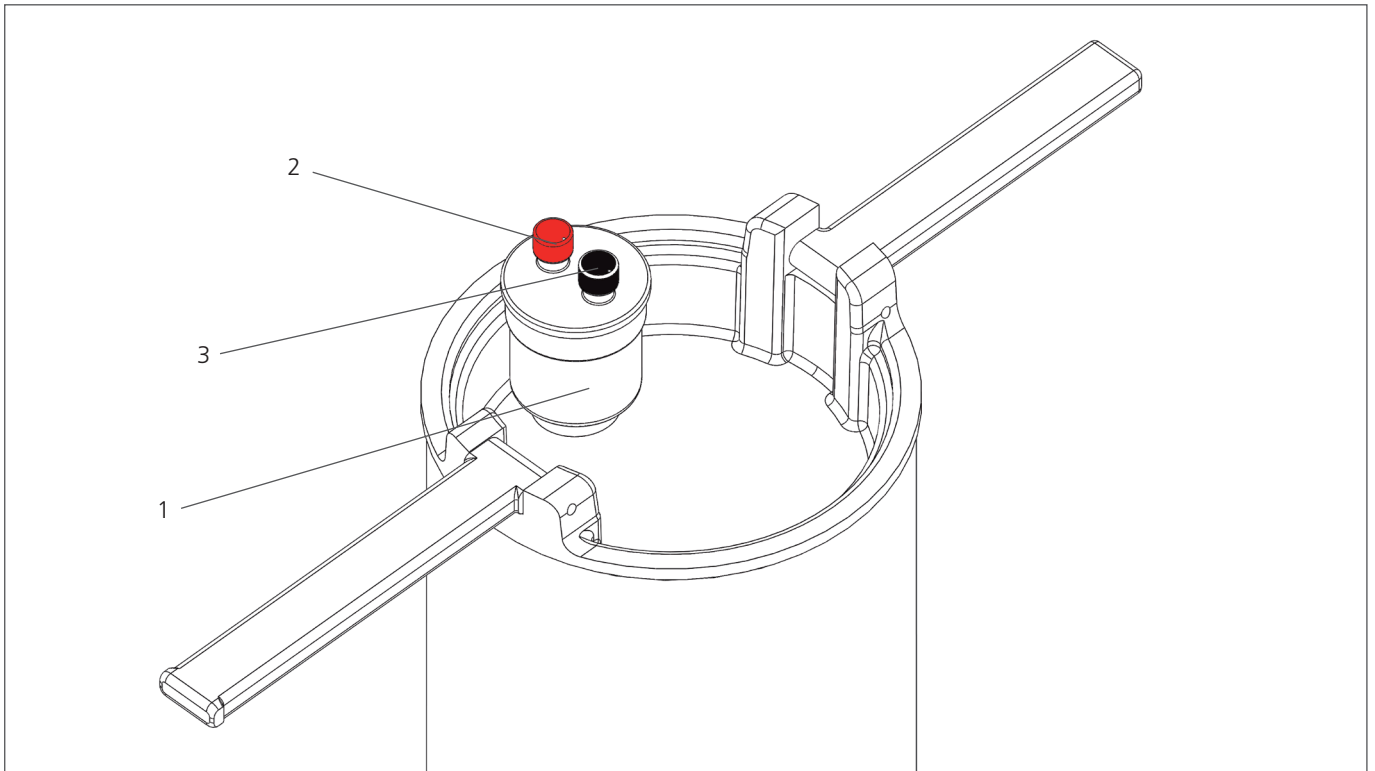

Fig.8: Venting

9.1 Switching on the device

To turn the unit on, press the ON / OFF switch.

9.2 Data collection

The OPCom sensor installed in the UMPCL 045 is equipped with a data memory which internally stores up to 3,000 results. When the memory capacity has been reached, the last measured value is stored and the oldest measured value is overwritten.

NOTE



A description of the installation and data transmission can be found in the OPCom user manual.

In the front panel of the UMPCL 045 unit there is a serial interface (fig. 5, page 13) via which the OPCom Particle Monitor can be read out and configured. For this purpose, a PC and an appropriate terminal program or a readout software is needed. The sensor has to be connected to a free COM port of a computer. A suitable communication cable for serial connection between sensor and computer / controller is described in Chapter 21("Accessories") of the OPCom manual. If the computer does not have a serial COM port, it is possible to use a USB-serial converter.

NOTE



The software can be downloaded from www.argo-hytos.com.

The stored results are transferred to the connected devices such as PC, laptop, tablet or smartphone and can be stored there.

CAUTION**Exposure to spilled oil
Injury / risk of slipping**

- › If oil leaks, the oil-covered area must be shut off immediately and covered with an oil binding medium (risk of slipping).

**Static charge
Sparking**

- › There is a risk of static charge when using poorly conducting hydraulic or lubricating oils. In this case, please consult the manufacturer.

NOTE**Inaccurate results
Erroneous measurements**

- › The measured values from the first 5 minutes should not be taken into account as the particle counter is initializing and the hydraulic circuit has to stabilize (air bubbles, flushing, etc.).
- › When using the adjustable flow version, it is recommended to measure the cleanliness class at a nominal flow rate of 45 l/min
- › The filter unit has a suction protection strainer on the suction side, which must be serviced regularly. A missing protective strainer can lead to the destruction of the pump. (Order No. see spare part list)
- › The manufacturer does not accept liability in case of the removal of the protective screen.
- › The filter unit is provided with screen filters installed before OPCOM sensor.
- › To provide the correct results of the cleanliness class, screen filters should be cleaned regularly.
- › An exact determination of the cleanliness class is possible in a viscosity range of 15 mm²/s to 300 mm²/s.

Operation	Position "lever"	Position "3-way ball valve"	Comment
Filtering when refilling	"Filtering"		see 10.1
Filtering in the bypass circuit	"Filtering"		see 10.2
Pumping	"Pumping"		see 10.3
Monitoring the oil cleanliness when filling	"Filtering"	Particle counting filling	see 10.4
Monitoring the oil cleanliness during cleaning	"Filtering"	Particle counting cleaning	see 10.5

Table 6: Operation modes

10.1 Filtering of hydraulic fluids when refilling

1. Connect the filter unit to a power source.
2. Insert the suction lance / suction pipe into the oil barrel.
3. Place the discharge pipe in a container (e.g. hydraulic tank).

NOTE



Incorrect insertion of the discharge pipe

- › Ensure that the discharge pipe is below the liquid surface.

4. Move the lever to the "Filtering" position.

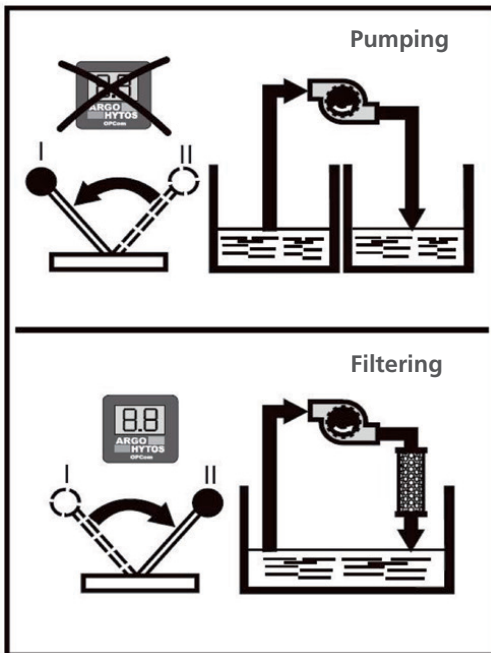

Fig. 9: Lever pumping / filtering

5. Switch on the filter unit at the on/off switch (circuit breaker).
6. Check the oil flow for a possible insufficient insertion depth of the suction pipe in the oil tank.

NOTE



- › At the beginning of the filtration, filling of the filter unit may take several seconds.

7. Monitor the filling level at the machine or system and switch off the filter unit at the circuit breaker after having reached the desired fill level.
8. After completion of the operation, pull the suction lance / suction tube out of the container / barrel and suck air for max. 30 seconds. Thus, the residual oil from the filter housing and the lines above the oil level is fed back into the same container via the discharge pipe.
9. Fix the suction lance / suction pipe and the discharge pipe to the corresponding brackets at the filter unit.

10.2 Filtering of liquids in the bypass flow

1. Connect the filter unit to a power source.
2. Insert the suction lance / suction pipe into the tank of the machine or system (e.g. hydraulic tank).
3. Place the discharge pipe into the machine or system container (e.g. hydraulic tank).

NOTE



- › At the beginning of the filtration, filling of the filter unit may take several seconds.

4. Move the lever to the "Filtering" position.

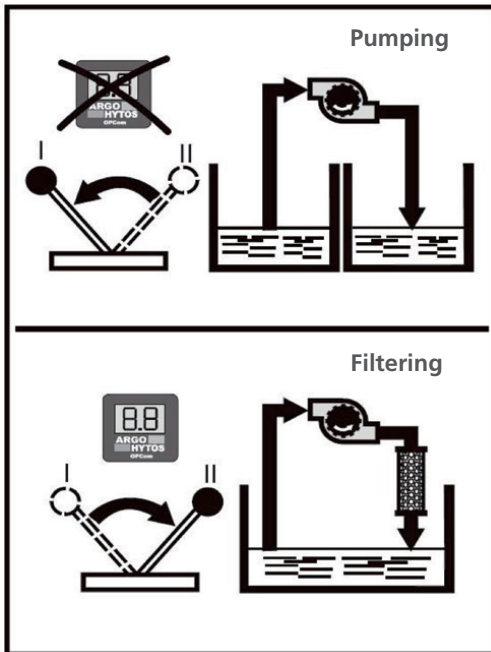

Fig. 10: Lever pumping / filtering

5. Switch on the filter unit at the on/off switch (circuit breaker).
6. Check the oil flow for a possible insufficient insertion depth of the suction pipe in the oil tank.
7. After completion of the filtration, pull the suction lance / suction tube out of the container of the machine or system (e.g. hydraulic tank) and suck air for max. 30 seconds. Thus, the residual oil from the filter housing and the lines above the oil level is fed back into the container of the machine or system via the discharge pipe.
8. Move the lever to the "Pumping" position.
9. Switch off the filter unit at the circuit breaker.
10. Fix the suction lance / suction pipe and the discharge pipe to the corresponding brackets at the filter unit.

NOTE



Achieving the maximum cleaning performance

- › In order to avoid a short circuit of the oil flow, the distance between the suction and the pressure connection should be as large as possible.

Falsification of results

- › Make sure that the device is properly vented.
- › An exact determination of the cleanliness class is possible in a viscosity range of 15 mm²/s to 300 mm²/s.

10.3 Pumping of hydraulic fluids (e.g. waste oil, filter is bypassed)

1. Connect the filter unit to a power source.
2. Insert the suction lance / suction pipe into the tank of the machine or system (e.g. hydraulic tank).
3. Place the discharge pipe into the container (e.g. empty oil barrel).
4. Move the lever to the "Pumping" position.

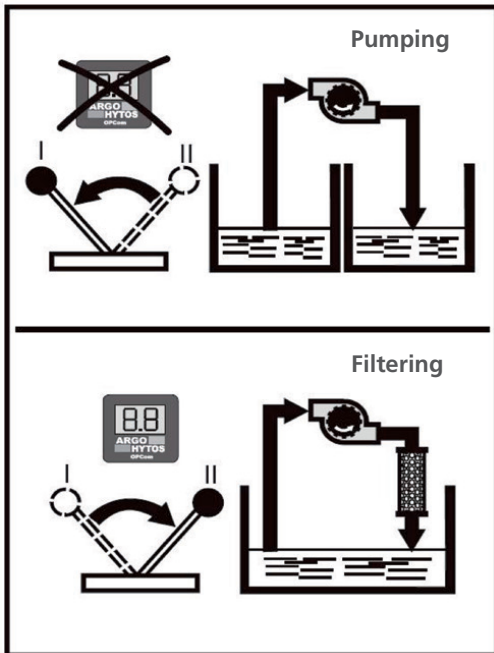

Fig. 11: Lever pumping / filtering

5. Switch on the filter unit at the on/off switch.
6. Check the oil flow (observe sufficient immersion depth of the suction lance in the hydraulic fluid).

NOTE



- › At the beginning of the filtration, filling of the filter unit may take several seconds.

7. Monitor the process.
8. After the machine or system has been completely emptied, switch off the filter unit at the circuit breaker.
9. Fix the suction lance / suction pipe and the discharge pipe to the corresponding brackets at the filter unit.

10.4 Flow adjustment (only available with UMPCL 045A)

1. During the pumping or filtration process, the output flow of the unit can be regulated in the range of 20-70 l/min.
2. In order to increase the flow rate, turn the potentiometer knob clockwise.



Fig. 12: Front panel with potentiometer for flow adjustment

10.5 Monitoring the oil cleanliness when filling machines and systems

1. Connect the filter unit to a power source.
2. Insert the suction lance / suction pipe into the tank of the machine or system (e.g. hydraulic tank).
3. Place the discharge pipe into the machine or system container (e.g. hydraulic tank).

NOTE



› At the beginning of the filtration, filling of the filter unit may take several seconds.

4. Move the lever to the "Filtering" position.

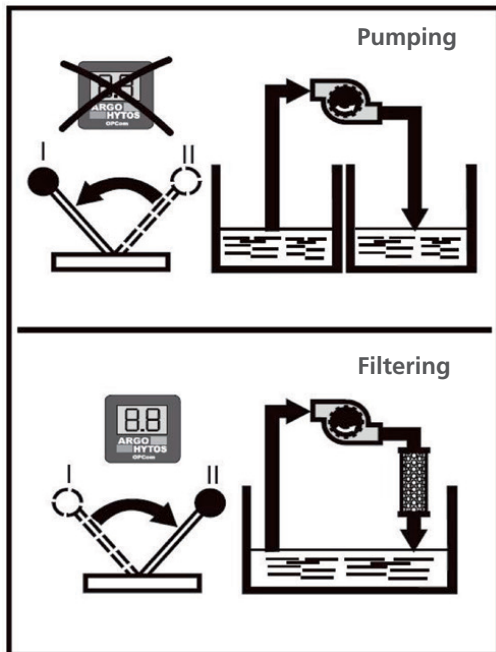
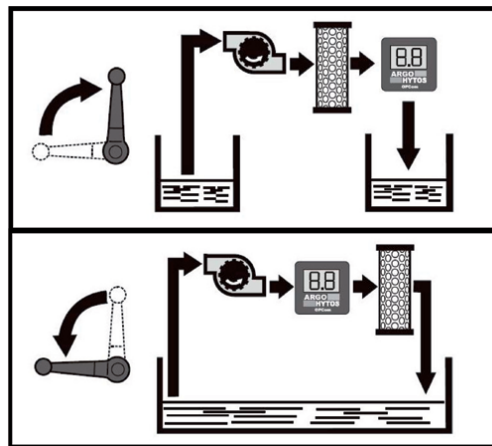

Fig. 13: Lever pumping / filtering

5. Set the three-way valve to the vertical position

Particle Counting "Filling" (AFTER filter)



Particle Counting "Cleaning" (BEFORE filter)

Fig. 14: Three-way valve

6. Switch on the filter unit at the on/off switch (circuit breaker) and let it operate for approx. 5 min. (Initialization of the particle counter and ventilation of the system).
7. Check the oil flow for a possible insufficient insertion depth of the suction pipe in the oil tank.
8. Monitor the filling level at the machine or system and switch off the filter unit at the circuit breaker after having reached the desired fill level.
9. After completion of the operation, pull the suction lance / suction tube out of the container / barrel and suck air for max. 30 seconds. Thus, the residual oil from the filter housing and the lines above the oil level is fed back into the same container via the discharge pipe.
10. Fix the suction lance / suction pipe and the discharge pipe to the corresponding brackets at the filter unit.

NOTE



- › No particle counting is possible with the "pumping" lever position.
- › Make absolutely sure that the unit is completely vented. Air bubbles can falsify the measurement results!
- › Make absolutely sure that the specified media temperatures of max. 80 ° C are observed.
- › Incorrect viscosities can falsify the measurement results!
- › An exact determination of the cleanliness class is possible in a viscosity range of 15 mm²/ s to 300 mm²/ s.
- › When using the adjustable flow version, it is recommended to measure the cleanliness class at a nominal flow rate of 45 l/min

10.6 Monitoring the oil cleanliness when cleaning machines and systems in the bypass flow

1. Connect the filter unit to a power source.
2. Insert the suction lance / suction pipe into the oil barrel (e.g. fresh oil).
3. Place the discharge pipe into the machine or system container (e.g. hydraulic tank).

NOTE



› At the beginning of the filtration, filling of the filter unit may take several seconds.

4. Move the lever to the "Filtering" position.

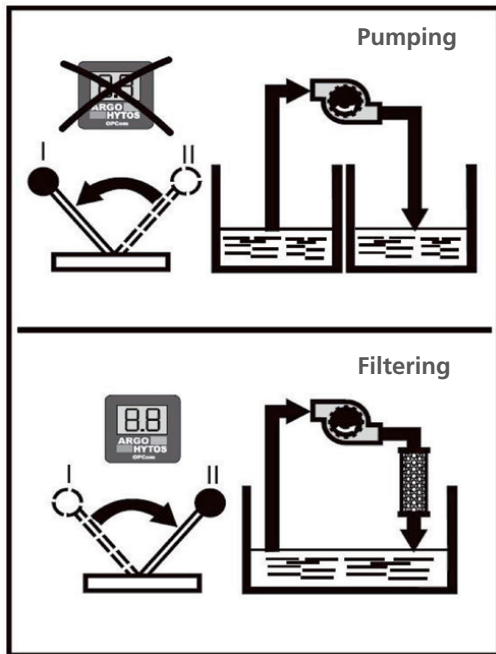
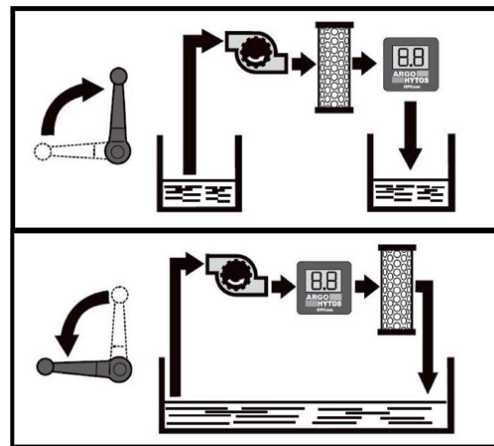

Fig. 15: Lever pumping / filtering

5. Set the three-way valve to the horizontal position

Particle Counting "Filling" (AFTER filter)



Particle Counting "Cleaning" (BEFORE filter)

Fig. 16: Three-way valve

6. Switch on the filter unit at the on/off switch (circuit breaker) and let it operate for approx. 5 min. (Initialization of the particle counter and ventilation of the system).
7. Check the oil flow for a possible insufficient insertion depth of the suction pipe in the oil tank.
8. Monitor the operation.
9. After completion of the filtration, pull the suction lance / suction tube out of the container of the machine or system (e.g. hydraulic tank) and suck air for max. 30 seconds. Thus, the residual oil from the filter housing and the lines above the oil level is fed back into the container of the machine or system via the discharge pipe.
10. Switch off the filter unit at the circuit breaker.
11. Fix the suction lance / suction pipe and the discharge pipe to the corresponding brackets at the filter unit.

 **DANGER**



Danger to life
Risk of electric shock

- › During repair work, turn off the unit and pull the mains plug.

 **CAUTION**



Hydraulic oil spills
Environmental hazard / risk of slipping

- › Before maintenance and repair work, completely drain the unit.
- › In case of spills, cover the oil-covered surface immediately with an oil-binding medium.
- › Then immediately dispose of the oil-binding medium according to the national environmental regulations.

Ignition hazard

Risk of electrostatic charge by poorly conducting hydraulic fluid.

- › If the electrical conductivity of the hydraulic fluid is not known, please contact the manufacturer of the hydraulic fluid.

Risk of burns

Contact temperatures according to DIN EN563 (3) and DIN EN13202 (4) may be exceeded during operation.

- › Allow the filter to cool down before touching it.

NOTE



Impaired function by dirt ingress into the pump.
The function of the filter unit is no longer guaranteed.

- › During repair work, all parts coming in contact with the hydraulic medium, must be kept free of dirt and chips.

11.1 Maintenance overview

Except from the filter element, suction strainer, and OPCom screen protective elements the filter unit is maintenance-free.

Maintenance work	Maintenance interval
Checking / changing the filter element	Once the clogging indicator responds at a permissible viscosity.

Table 7: Maintenance overview

11.2 Changing the filter element

1. Pump the filter element empty (see Chapter 10.2 "Filtering of liquids in the bypass flow", point 7).
2. Disconnect the off-line filter unit from the power supply and, if necessary, pull the mains plug.

 **CAUTION**



Risk of burns

Contact temperatures according to DIN EN563 (3) and DIN EN13202 (4) may be exceeded during operation.

- › Allow the filter unit to cool down before touching it.

11.3 Removing filter element



Fig. 17: Removing the filter element

1. Turn the housing cover (1) counterclockwise.
2. Carefully remove the cover (1) with the filter element (2) from the filter tube.
(The filter element is attached to the cover.
Let the draining oil drip off into the housing.)

11.3.1 Removing the filter element from the cover

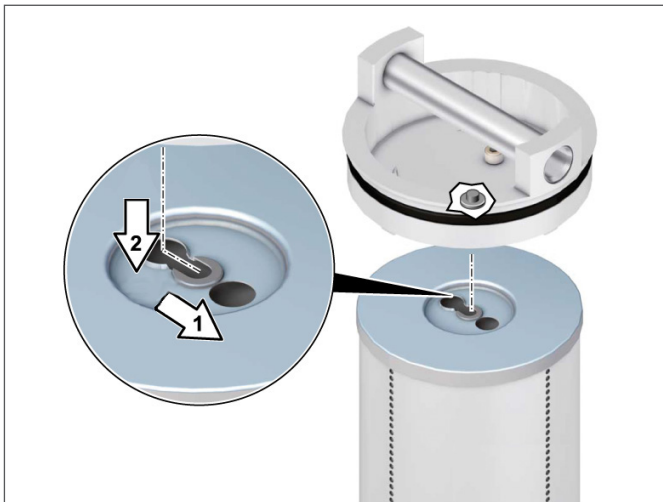

Fig. 18: Removing the filter element from the cover

1. Push the filter element at the cover in arrow direction 1 and remove it in arrow direction 2.
2. Dispose of the filter element according to the national environmental legislation
(Waste code: Oil filter 16 01 07).

11.3.2 Attaching the filter element



Fig. 19: Attaching the filter element

1. Check the filter element type number.
Does the laser inscription on the filter element match with the indications on the type plate or in the operating manual?
2. Attach the filter element in arrow direction 1 and lock it in arrow direction 2.

11.3.3 Installing the filter element



Fig. 20: Installing the filter element

1. When changing the filter element, always replace the O-ring in the cover (supplied with the filter element) (O-ring Order No. N007.1175, included with replacement filter elements).
2. Carefully insert the cover (1) with the filter element (2) into the filter tube.
3. Screw in the cover manually until it stops. A gap (2-3 mm) between the cover and the filter tube may remain visible.

NOTE



ARGO-HYTOS offers you a comprehensive service package for the repair of the filter unit UMPCL 045.

- › Repairs to the filter unit UMPCL 045 may only be carried out by the manufacturer or his authorized dealers and branches. No warranty is given for self-made repairs.

11.4 Checking / changing the suction filter element (pump protection filter)

11.4.1 Removing the suction filter

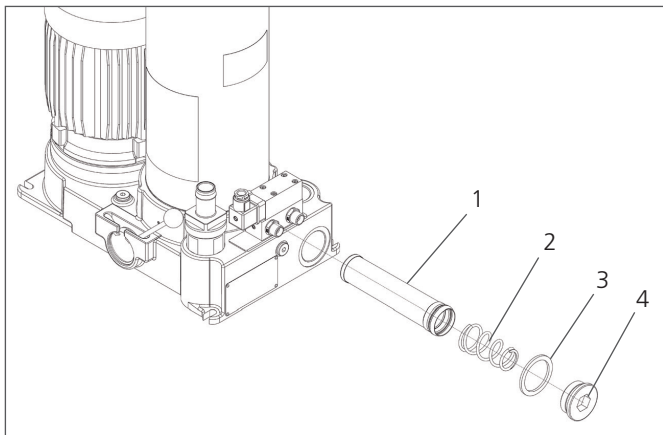

Fig. 21: Removing the suction filter

1. Provide a drip tray for residual oil and the contaminated filter element.
2. Open the locking screw (4) with an Allen key AF 22.
3. Remove the contaminated element (1) with the spring (2) by pulling it slightly out of the housing.
4. Dispose of the suction filter element in an environmentally friendly manner (Waste code: Oil filter 16 01 07).

11.4.2 Installing the suction filter

1. Always replace the sealing ring (3) after each change of the suction filter element.
2. Carefully insert the suction filter element (1) with the spring (2) into the pump block.
3. Screw in the locking screw (4) and tighten it with a torque of 25 ± 2.5 Nm.
4. Check the locking screw for tightness after commissioning and tighten it if necessary.

NOTE



When the filter element is changed, oil accidentally spilled onto components of the filter and pumping unit can create the appearance of a leak.

- › As far as possible - remove any residual oil from the device!

11.5 Checking / cleaning OPCom protective filters

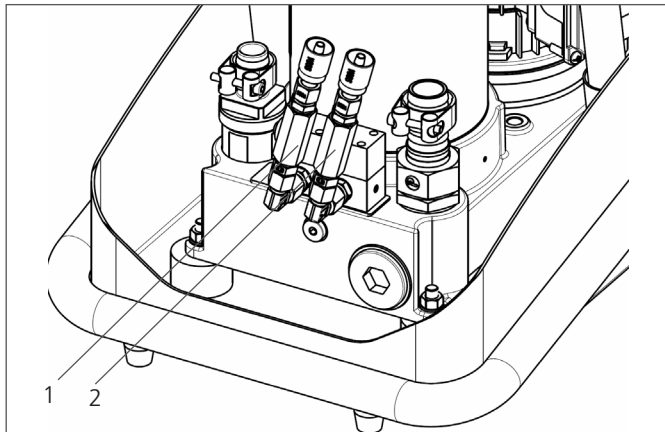

Fig. 22: Removing screen filters

1. Provide a drip tray for residual oil and the contaminated filter element.
2. Unscrew both filters (1) ,(2)
3. Clean filters using cleaning agent and compressed air. If necessary install new filters (order no. 15077600)
4. Install filter to the system

The filter unit UMPCL 045 is a component which does not have to be taken out of service. Therefore, the chapter in this manual does not contain any information.

This chapter does not contain any information for your device.

14.1 Environmental protection

Careless disposal of the filter unit UMPCL 045 and the pressurized fluid can lead to environmental pollution. Therefore, dispose of the filter unit and the pressure fluid according to the national regulations of your country. Dispose of pressure fluid residues according to the relevant safety data sheets for these pressure fluids.

Do not modify the UMPCL 045 filter unit.

NOTE



The warranty of ARGO-HYTOS applies to the delivered configuration and extensions, which were taken into account during configuration.
The warranty expires after a conversion or extension that goes beyond the conversions or extensions described here.

Unauthorized conversions or extensions, which are not described in this chapter, make the CE marking invalid.

16.1 Basic procedure

- › You should also be systematic and targeted under time pressure.
Random, unsupervised dismantling and adjustment of setting values can lead to the fact, that the original cause of the fault cannot be detected anymore.
- › Get an overview on the function of the particle monitor OPCom Portable in connection with the overall system.
- › Try to find out whether the product has provided the required function in the overall system before the error occurred.
- › Try to record changes to the overall system in which the particle monitor OPCom Portable is installed:
- › Have the operating conditions or the area of application of the particle monitor OPCom Portable been changed?
- › Have modifications (e.g. conversions) or repairs been carried out at the overall system (device / unit, electrics, control) or at the product? If so, which modifications?
- › Has the product or the device been operated correctly?
- › How does the fault tend to show?
- › Get a clear impression about the cause of trouble. Possibly consult the direct operator.

If you cannot correct the error, please contact one of the contact addresses listed under www.argo-hytos.com.

If the device should not accept any more entries, turn it off briefly and then turn it on again after a few seconds. After initialization, the particle monitor will operate as usual.

Error	Reason	Measure
E-motor can not be switched on during commissioning	<ul style="list-style-type: none"> › E-cable or plug defective › Missing mains voltage › Motor defective › Pump defective › Too high viscosity (medium) 	<ul style="list-style-type: none"> › Have the cables disconnected by qualified personnel › Establish power supply / activate electrical fuse › Replace motor (repair at manufacturer) › Replace pump (repair at manufacturer) › Heat medium
E-motor switches off during operation	<ul style="list-style-type: none"> › Filter element contaminated › Suction strainer contaminated › Viscosity too high › Suction height too big › Leakage on the suction side › Wear of the pump 	<ul style="list-style-type: none"> › Replace filter element › Replace the suction strainer › Heat medium › Adjust suction height › Replace the suction hose or seal the connection points (retighten them) › Replace pump (repair at manufacturer)
Too loud operating noise	<ul style="list-style-type: none"> › Filter element contaminated › Suction strainer contaminated › Viscosity too high › Suction height too big › Leakage on the suction side › Filter unit is mounted on a vibration-sensitive base (sheet metal) 	<ul style="list-style-type: none"> › Replace filter element › Replace the suction strainer › Heat medium › Adjust suction height › Replace the suction hose or seal the connection points (retighten them) › Improve your local conditions
Pump does not suck	<ul style="list-style-type: none"> › Leakage on the suction side › Sealing plug of the screen element is leaking › Unit is pumped empty (when refilling) 	<ul style="list-style-type: none"> › Replace the suction hose or seal the connection points (retighten them) › Check / replace sealing ring, check tightening torque › Prime the unit (0.5 l to 3 l)
Cleanliness classes displayed on the OPCom do not change during cleaning	<ul style="list-style-type: none"> › Max. dirt capacity of the filter element is reached › Leakage at the suction hose, falsification of the measurement results by free air in the oil (air bubbles) › Rotary valve on lever position "Pumping" 	<ul style="list-style-type: none"> › Replace filter element › Check the suction connection, if necessary, tighten the hose clips / check the oil for foaming or air bubbles and eliminate the cause. If the cause cannot be eliminated, take the oil sample and have it evaluated in the laboratory. Vent the filter unit › No particle counting is possible with the lever position "Pumping"
Cleanliness classes displayed on the OPCom become poorer during cleaning	<ul style="list-style-type: none"> › Max. dirt capacity of the filter element is reached › Leakage at the suction hose, falsification of the measurement results by free air in the oil (air bubbles) › Rotary valve on lever position "Pumping" 	<ul style="list-style-type: none"> › Replace filter element › Check the suction connection, if necessary, tighten the hose clips / check the oil for foaming or air bubbles and eliminate the cause. If the cause cannot be eliminated, take the oil sample and have it evaluated in the laboratory. Vent the filter unit › No particle counting is possible with the lever position "Pumping"
Displayed cleanliness classes are not plausible (e.g. 0/0/0)	<ul style="list-style-type: none"> › Viscosity range below or exceeded. Particle counter is supplied with too little or too much oil › Rotary valve on lever position "Pumping" › Screen filters clogged 	<ul style="list-style-type: none"> › Adjust the fluid temperature (also see operating conditions) › No particle counting is possible with the lever position "Pumping" › Clean screen filters
After cleaning for high cleanliness classes no further improvement (e.g. order number 10 at 4, 6 and 14 µm).	<ul style="list-style-type: none"> › Set measuring time is too short 	<ul style="list-style-type: none"> › Observe the defined limit values for oils with cleanliness classes according to ISO 4406. Upper limit value: 24 (for 4, 6 and 14 µm) Lower limit value: 10 (for 4, 6 and 14 µm)

Table 8: Error description

17.1 Dimension drawing

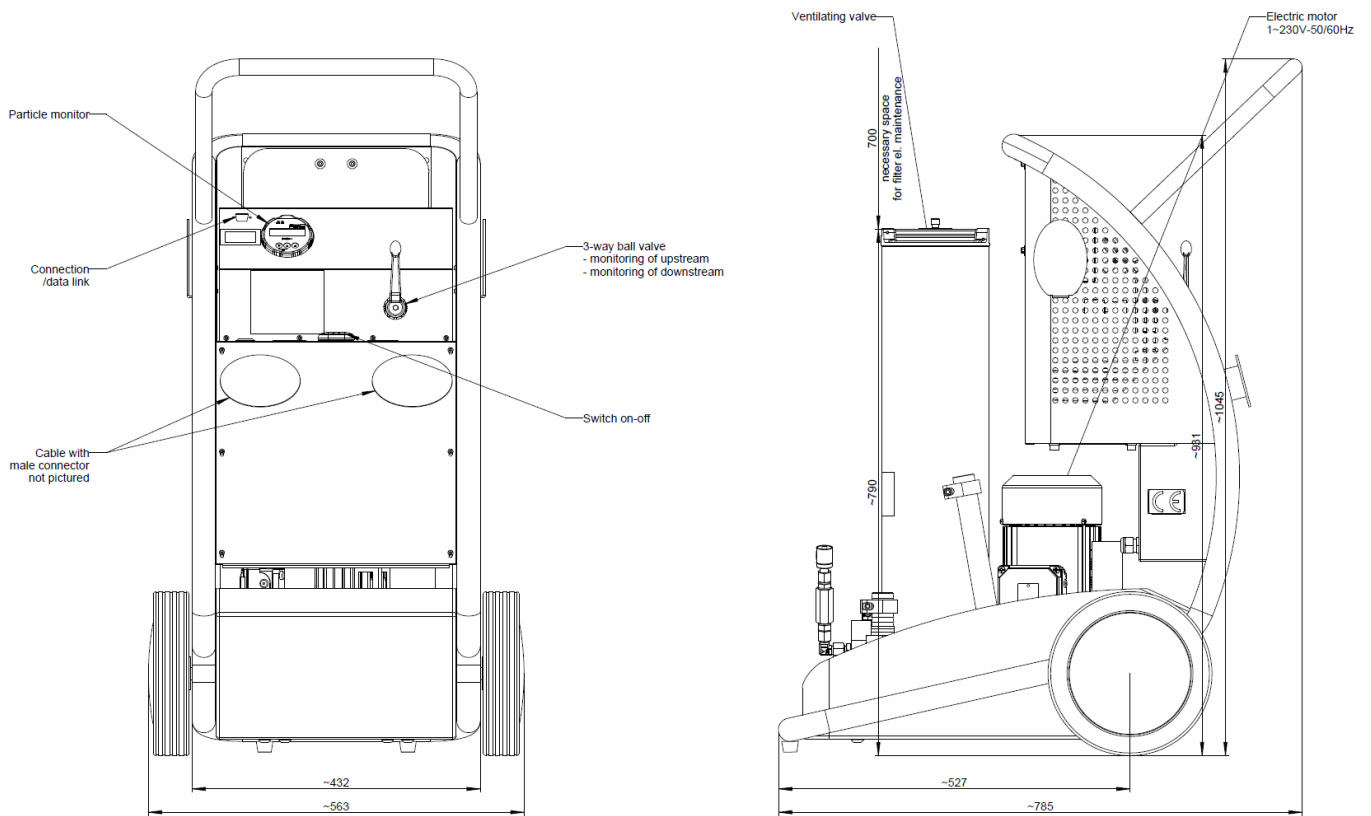

Fig. 23: Dimension drawing

17.2 Technical data

Nominal flow	l/min (50 Hz) l/min (50 Hz)	45 20 - 70	UMPCL 045F - version with fixed nominal flow rate UMPCL 045A - version with adjustable nominal flow rate
Pressure relief valve	bar	6 ± 0.5	
Pressure holding valve	bar	2.5 ± 0.5	
Max. operating pressure	bar	7	
Filter element		V7.1560-103 β3(c) ≥ 200 V7.1560-03 β5(c) ≥ 200 V7.1560-06 β10(c) ≥ 200	
Clogging indicator		Optical clogging indicator DG 042-01 p = 2.0 ± 0.3 bar	
Suction side		Connection G 1 ¼" with hose DN 32 and suction lance (when replacing the suction hose only use a spiral hose)	
Pressure side		Connection G1" with hose DN 25 and pressure lance	
Suction strainer		Screen element 280 μm	
Electric drive		1-Phase alternating current motor 230 V; 50 / 60 Hz; 1.1 kW; n = 1,500/1,800 min ⁻¹ ; Size 90 3-Phase AC motor 400 / 460 V; 50 / 60 Hz; 1.1 kW; n = 1,500 / 1,800 min ⁻¹ ; Size 90	
Weight	kg	approx. 88	
Sound power level	db(A) max.	max. 73 (Under operating conditions permissible for continuous operation) max. 78 (Under operating conditions permissible for short-term operation)	
Dimensions	l x w x h	786 x 564 x 1,045	

Table 9: Technical data

17.3 Operating conditions



Risk of burns

Contact temperatures according to DIN EN563 (3) and DIN EN13202 (4) may be exceeded during operation.

- › Allow the filter unit to cool down before touching it.

NOTE



Variable viscose behavior

- › Viscosities of a medium are always temperature-dependent.

Electric drive 1 ~ 230 V 50/60 Hz (UMPCL 045F - fixed nominal flow)	mm ² /s (min. continuous operation) mm ² /s (max. continuous operation)	15 600 (An exact determination of the cleanliness class is possible in a viscosity range of 15 mm ² /s to 300 mm ² /s.)
Electric drive 3 ~ 400 V 50/60 Hz (UMPCL 045F - fixed nominal flow)	mm ² /s (min. continuous operation) mm ² /s (max. continuous operation)	15 600 (An exact determination of the cleanliness class is possible in a viscosity range of 15 mm ² /s to 300 mm ² /s.)
Electric drive 3 ~ 400 V 50/60 Hz (UMPCL 045A - adjustable nominal flow)	mm ² /s, viscosity range for 20 l/min mm ² /s, viscosity range for 45 l/min mm ² /s, viscosity range for 70 l/min	15 - 1100 15 - 600 15 - 400 (An exact determination of the cleanliness class is possible in a viscosity range of 15 mm ² /s to 300 mm ² /s; It is recommended to measure the cleanliness class with a nominal flow of 45 l/min)
Permissible temperature range	Hydraulic fluid °C Surroundings °C	10 ... 65 0 ... 50
Permissible suction heights	m (max.) first use m (max.) operating condition	2 6
Media resistance		Hydraulic fluids based on mineral oil, rapeseed oils and synthetic esters.
Mains fuses		230 V, 50/60 Hz, 16 A 400/460 V, 50/60 Hz, 16 A
Working position		standing

Table10: Operating conditions

17.4 Hydraulic circuit diagram

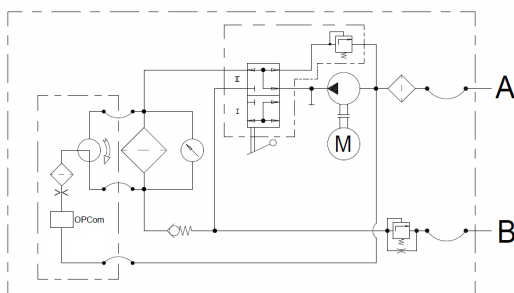

Fig. 24.1: Hydraulic diagram UMPCL 045F

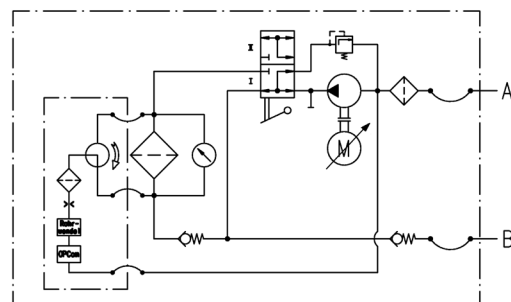

Fig. 24.2: Hydraulic diagram UMPCL 045A

18.1 Declaration of conformity

EC Declaration of Conformity

We, the company,

ARGO-HYTOS Polska sp. z o.o.
Władysława Grabskiego 27
32-640 Zator, Poland,

declare on our sole responsibility that the products in the model series

Mobile filter unit UMPCL 045

to which this declaration pertains are in conformity with the following directives:

Directive 2006/42/EC (Machinery Directive)
Directive 2014/30/UE (EMC Directive)

Conformity with the directives is assured through compliance with the following standards:

EN 809:1998+A1:2009/AC:2010

Pumps and pump units for liquids -Common safety requirements

EN 60204-1:2018

Safety of machinery -- Electrical equipment of machines -- Part 1: General requirements

Zator, 25.03.2021



Arkadiusz Noworyta
AHPL Generaldirektor

18.2 Spare parts

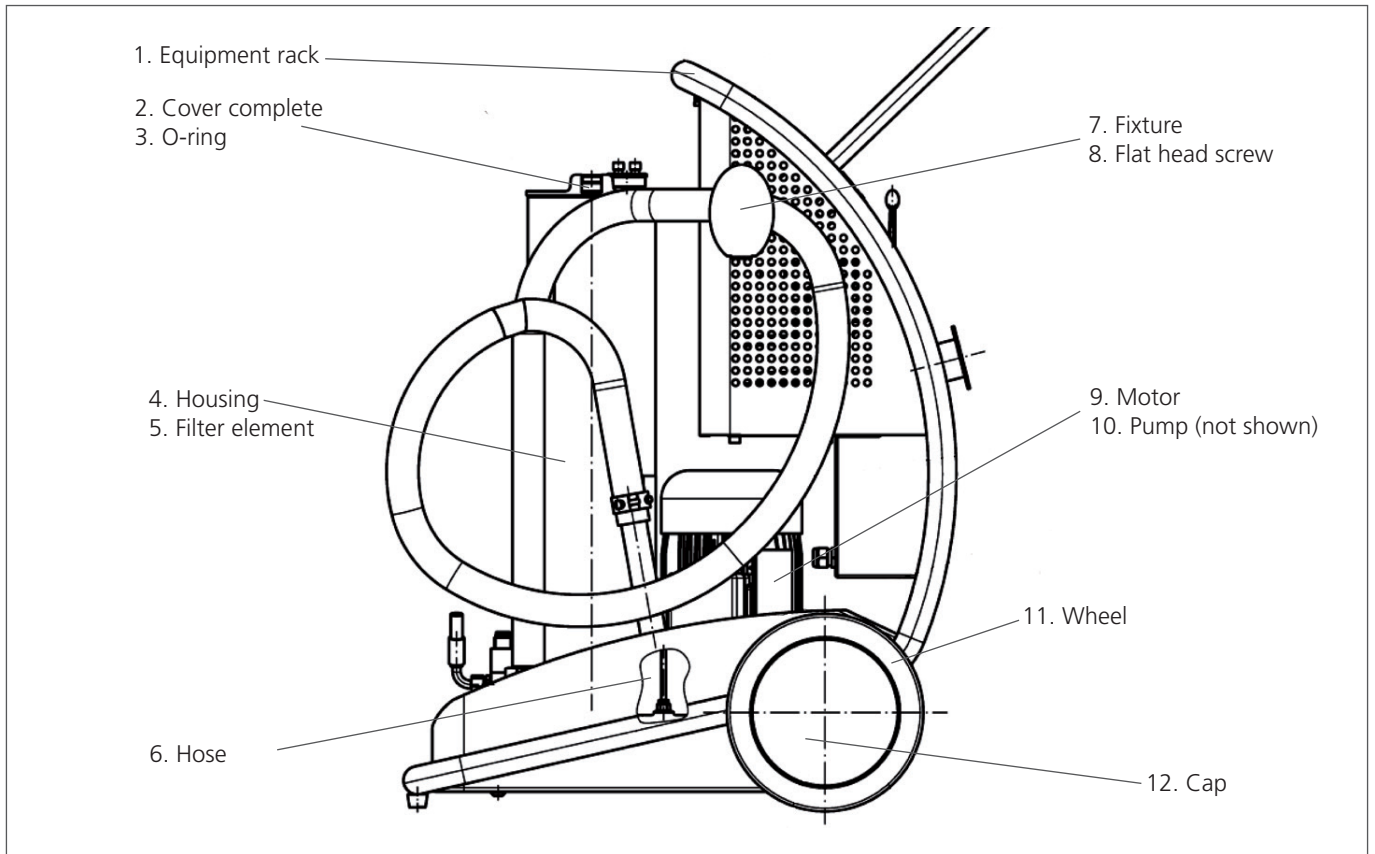

Fig. 25: Spare parts drawing 1

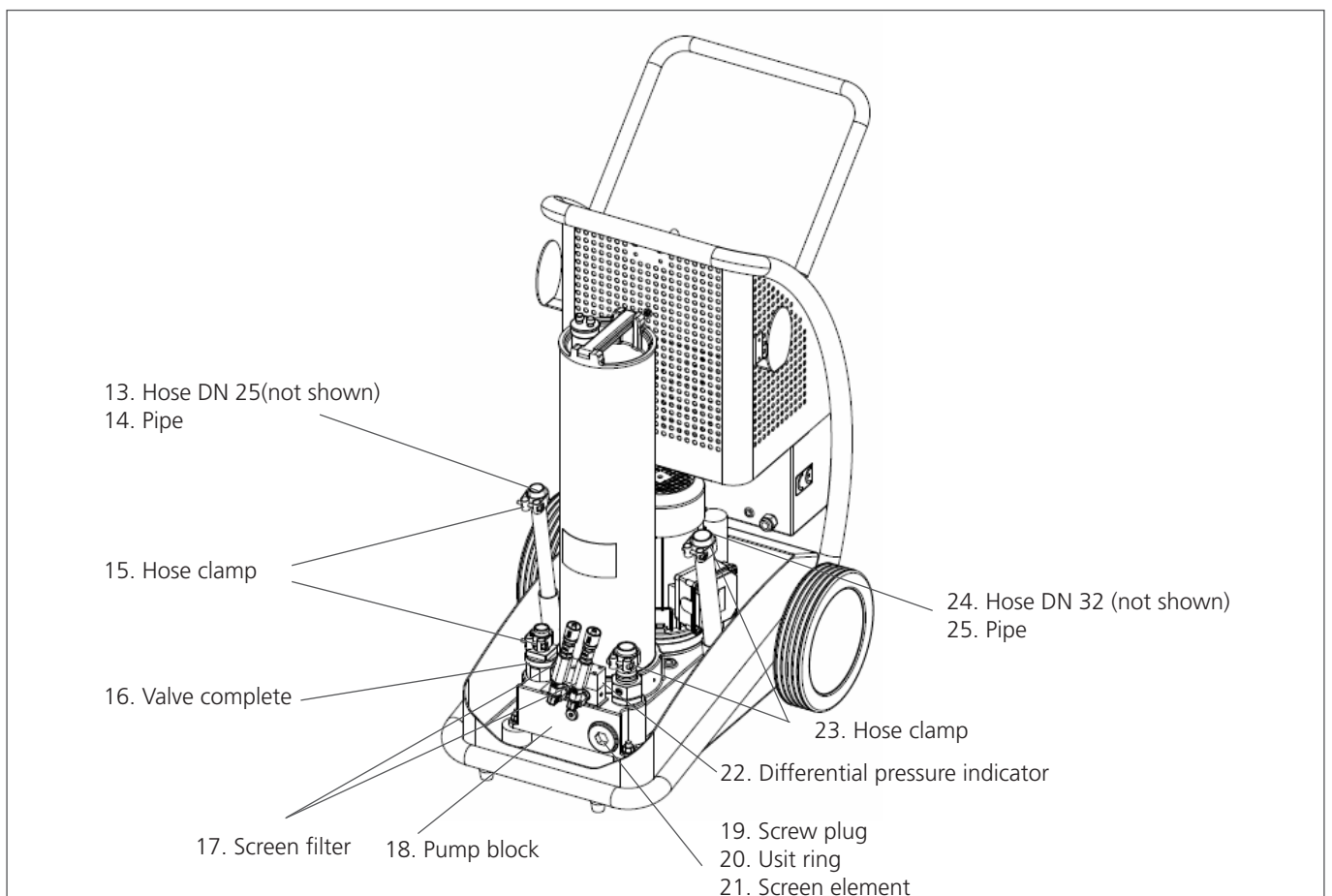

Fig. 26: Spare parts drawing 2

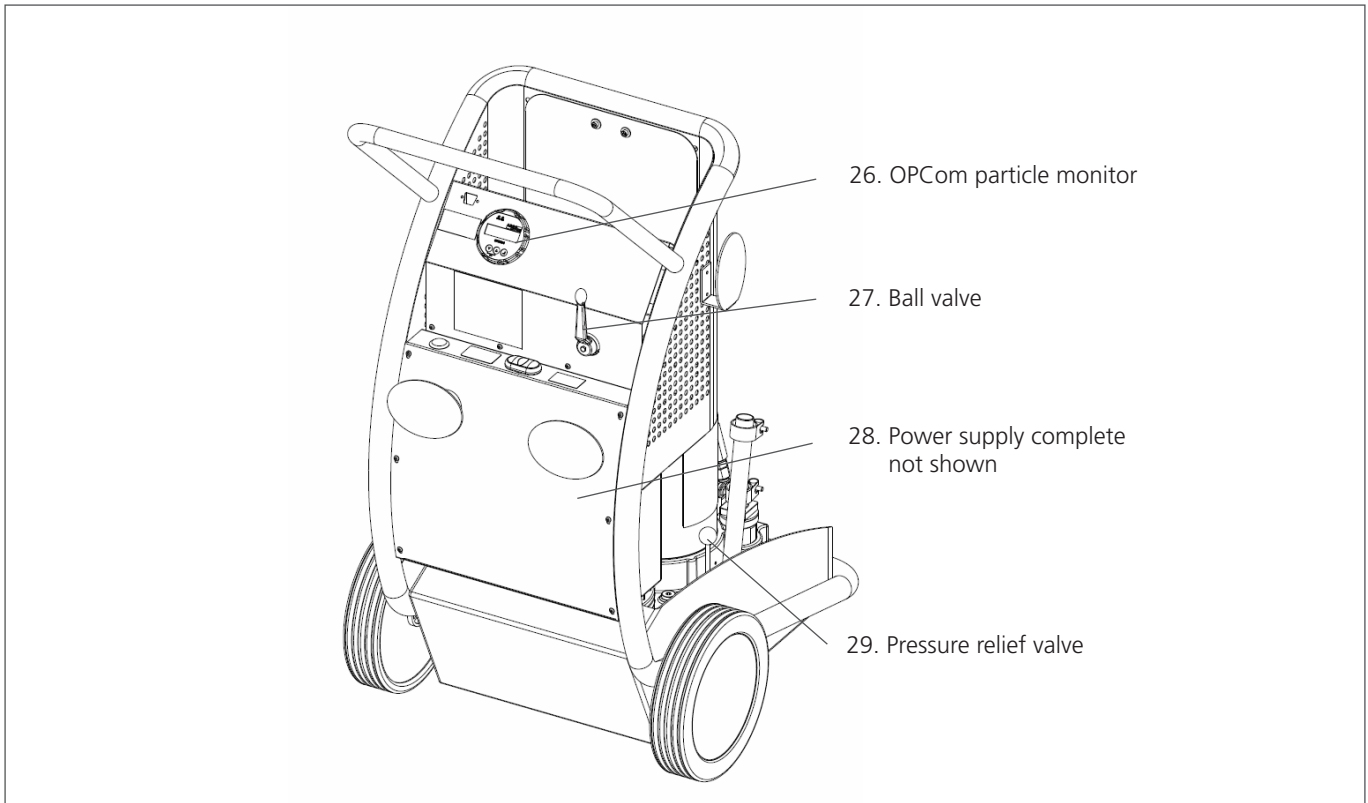

Fig. 27: Spare parts drawing 3

Number.	Designation	Pieces	Order No.	Comment
1	Equipment rack	1	UM 045.1735	
2	Cover complete	1	FNA 045.1210	incl. Pos. 3
3	O-ring	1	N007.1455	NBR
4	Filter housing	1	FNA 045.0103	
5.1	Filter element	1	V7.1560-103	3 µm (c)
5.2	Filter element	1	V7.1560-03	5 µm (c)
5.3	Filter element	1	V7.1560-06	10 µm (c)
6	Hose	2	17505401	
7	Fixture	2	UM 045.0758	
8	Flat head screw ISO 7380	4	13674300	
9.1	Motor	1	33592200	1~230 VAC
9.2	Motor	1	33592300	3~400 VAC
10	Pump	1	FNA 045.1900	
11	Wheel	2	UM 045.0710	
12	Wheel cap	2	UM 045.0711	
13	Pressure hose	1	UM 045.0750 o. Z.	DN 25, 2.5 meters
14	Pipe	1	UM 045.0756	0.4 meter
15	Hose clamp	2	13797700	GBS 32-35mm W1
16	Valve complete	1	41247400	
17	Screen filter	2	15077600	
18	Pump block	1	FNA 045.0104	
19	Screw plug	1	32158100	M45x2
20	USIT ring	1	17523000	57.1x45.3x3.2
21	Screen element	1	S9.0417-13	
22	Differential pressure indicator	1	DG 042-01	Optical
22.1	M4x30 screw ISO 4762	4	11272600	for mounting pos. 22
22.2	M4 spring washer DIN127 Zn	4	11272700	for mounting pos. 22
23	Hose clamp	2	13797900	GBS 38-41mm W1
24	Suction hose	1	UM 045.0751 o. Z.	DN 32, 2.5 meters
25	Pipe	1	UM 045.0757	0.4 meter
26	OPCom particle monitor	1	SPCO 300-1000	
27	Ball valve	1	14218300	
28	Power supply complete	1	31168900	
29	Pressure relief valve	1	17008401	

Table 11: Spare parts list

International

ARGO-HYTOS worldwide

Benelux	ARGO-HYTOS B.V.	info.benelux@argo-hytos.com
Brazil	ARGO-HYTOS AT Fluid Power Systems LTDA.	info.br@argo-hytos.com
China	ARGO-HYTOS Fluid Power Systems	info.cn@argo-hytos.com
Czech Republic	ARGO-HYTOS s.r.o ARGO-HYTOS Protech s.r.o	info.cz@argo-hytos.com info.protech@argo-hytos.com
France	ARGO-HYTOS SARL	info.fr@argo-hytos.com
Germany	ARGO-HYTOS GMBH	info.de@argo-hytos.com
Great Britain	ARGO-HYTOS Ltd.	info.uk@argo-hytos.com
Hong Kong	ARGO-HYTOS Hong Kong Ltd.	info.hk@argo-hytos.com
India	ARGO-HYTOS PVT. LTD.	info.in@argo-hytos.com
Italy	ARGO-HYTOS S.r.l.	info.it@argo-hytos.com
Poland	ARGO-HYTOS Polska spz o.o.	info.pl@argo-hytos.com
Russia	ARGO-HYTOS LLC	info.ru@argo-hytos.com
Sweden	ARGO-HYTOS Nordic AB	info.se@argo-hytos.com
Turkey	ARGO-HYTOS Hid Ekip. San. ve Tic Ltd. Sti.	info.tr@argo-hytos.com
USA	ARGO-HYTOS Inc.	info.us@argo-hytos.com

