

OPCom Particle Monitor

SPCO 300-1000 / 2000 / 1200



Safety and operating instructions

Read safety and operating instructions before use.

Note: The indicated data only serve to describe the product.

Information regarding the use of this product are only examples and suggestions.

Catalog specifications are no guaranteed features.

The information given does not release the user from his / her own assessments and inspections.

Our products are subject to a process of natural wear and aging.

© All rights are reserved by ARGO-HYTOS GMBH, even in the event of industrial property rights.

Any right of disposal such as copying and distribution rights shall remain with us.

The picture on the title page shows a configuration example. The delivered product may thus differ from the illustration.

Original instruction

Contents

	Contents	2
1.	About this documentation	5
1.1	Applicability of this documentation	5
1.2	Required and supplementary documentation	5
1.3	Presentation of information	5
1.3.1	Safety instructions	5
1.3.2	Symbols	6
1.3.3	Terms	6
1.3.4	Abbreviations	6
2.	Safety instructions	7
2.1	About this chapter	7
2.2	Intended use	7
2.3	Improper use	7
2.4	Reasonably foreseeable misuse	7
2.5	Qualification of personnel	7
2.6	General safety instructions	8
2.7	Product and technology related safety instructions	8
2.8	Indications on the product	8
3.	General instructions	10
4.	Scope of delivery	11
5.	About this product	12
5.1	Functional description	12
5.2	Component overview	13
5.3	Identification of the product	13
6.	Transport and storage	14
7.	Assembly	15
7.1	Operating site	15
7.2	Hydraulic connection	15
7.3	Mounting	16
7.4	Mechanical stress	17
8.	Electrical connection	18
8.1	Pin assignment (view from above)	18
9.	Commissioning	19
9.1	Before commissioning	19
10.	Start screen	20
10.1	Status display	20
10.2	Time display	20
10.3	Displayed standard	20
10.4	Ordinal numbers	20
11.	Menu and operation	21
11.1	Menu structure	22
11.2	Operating modes	23

11.2.1	Time-controlled measurement	23
11.2.2	Digital I/O	23
11.2.3	Button	23
11.2.4	Automatic	24
11.3	Alarm configuration	24
11.3.1	Alarm type	24
11.3.1.1	Standard alarm	24
11.3.1.2	Filter mode	25
11.3.1.3	Temperature alarm	25
11.3.2	Alarm memory	25
11.3.3	Low-pass filter	25
11.4	Configuration analog	26
11.5	Standard	27
11.6	Configuration flow	27
11.6.1	Automatic	27
11.6.2	Fix	27
11.7	Communication	27
11.7.1	Type	27
11.8	Baud rate CAN	28
11.8.1	Node ID CAN	28
11.8.2	Baud rate RS232	28
11.8.3	Automatic transmission	28
11.9	Configuration display	29
11.10	Sensor parameter	29
11.10.1	Measurement results	29
11.10.2	Electronics	29
11.10.3	Operating hours	30
11.10.4	Error info	30
11.10.5	Flow settings	30
11.11	Language	30
12.	Calibration	31
12.1	Calibration note	31
13.	Analog current output (4...20mA)	32
13.1	Measurement without load resistance	32
13.2	Measurement with load resistance	32
13.3	Configuration	32
13.4	Conversion of the analog current output to the ordinal number	32
13.5	Sequential data output for ISO 4406:17 and SAE AS 4059E	33
14.	Switching inputs and outputs	34
14.1	Digital input	34
14.2	Switching output	34
14.2.1	Option 1	34
14.2.2	Option 2	35
15.	Communication RS232	36
15.1	Interface parameters	36
15.2	Read commands	36
15.3	Configuration commands	38
15.4	Checksum calculation (CRC)	41
16.	Communication CAN	42
16.1	CANopen	42
16.1.1	„CANopen Object Dictionary“ in general	43
16.1.2	CANopen Communication Objects	43
16.1.3	Service Data Object (SDO)	44
16.1.4	Process Data Object (PDO)	46
16.1.5	PDO Mapping	46
16.1.6	„CANopen Object Dictionary“ in detail	48
16.2	CAN J1939	53

17.	Classification systems	54
17.1	Definition of particle sizes	54
17.1.1	Cleanliness classes according to ISO 4406:17	54
17.1.2	Cleanliness classes according to SAE AS 4059E	55
17.1.3	Cleanliness classes according to NAS 1638.....	56
17.1.4	Cleanliness classes according to GOST 17216	57
18.	Maintenance and repair	58
18.1	Maintenance	58
18.2	Repair.....	58
19.	Decommissioning, disassembly, disposal	59
19.1	Environment	59
20	Accessories	60
21.	Troubleshooting.....	61
22.	FAQ	62
23.	Technical data.....	64
23.1	Technical data.....	64
23.2	Dimensional drawing	65
24.	Appendix.....	66
24.1	Cable lengths	66
24.2	Coding of error bits	66
24.3	Particle contaminations.....	68

1. About this documentation

1.1 Applicability of this documentation

This documentation is applicable for the following products:

- › OPCOM Particle Monitor
- › OPCOM Particle Monitor Phosphate Ester
- › OPCOM Particle Monitor without display

This documentation is written for service engineers, technicians, operators and system operators.

This document contains important information for safe and appropriate assembly, transport, activation, operation, usage, servicing, dismantling and simple troubleshooting.

- › Read this document completely and in particular the chapter, "Safety Instructions," before you work with the product.

1.2 Required and supplementary documentation



	Title	Number of document	Document type
	Data sheet	100.50	Data sheet
	Quick start	29808300	Quick start

Table 1: Required and supplementary documentation

1.3 Presentation of information

So that this document can help you to work quickly and safely with your product, we use standardized safety instructions, symbols, terms and abbreviations. For better understanding, these are explained in the following sections.

1.3.1 Safety instructions

In this documentation, safety instructions are faced with a sequence of actions which would result in the danger of personal injury or damage to equipment. The measures described to avoid these hazards must be observed.

Safety instructions are structured as follows:

 SIGNAL WORD
Type and source of danger Consequences of non-compliance › Measures for safety and hazard defense › <List>

- › Warning signal: draws attention to the danger
- › Signal word: indicates the severity of the danger
- › Type and source of danger: specifies the type and source of danger
- › Consequences: describes the consequences of non-compliance
- › Measures: describes how to deal with the risk



Warning sign, signal word	Meaning
 DANGER	Indicates a dangerous situation which results in death or serious injury if not avoided.
 WARNING	Indicates a dangerous situation which may result in death or serious injury if not avoided.
 CAUTION	Indicates a dangerous situation which may result in light to moderate injury if not avoided.
NOTE	Indicates equipment damage: The product or surrounding could be damaged.

Table 2: Meaning of warning signs

1.3.2 Symbols

The following symbols indicate notes which are not safety-relevant but increase the intelligibility of the documentation.



Symbol	Meaning
	If this information is not observed, the product can not optimally be used or operated
	This symbol warns against laser beams.
	Singular, independent action step / instruction
1. 2.	Numbered instruction The numbers indicate that the action steps follow one another

Table 3: Meaning of symbols

1.3.3 Terms

In this documentation the following terms are used:

Term	Meaning
$\mu\text{m(c)}$	Size specification for particles when using ISO-MTD

Table 4: Terms

1.3.4 Abbreviations

Abbreviation	Meaning
OL	Ordinal number
APC	Automatic particle counter
MTD	Medium test dust
mm	Double-digit indication of minutes
ss	Double-digit indication of seconds

Table 5: Abbreviations

2. Safety instructions

2.1 About this chapter

This product was manufactured according to the generally recognized standards of engineering. Nevertheless, there is a danger of injury or damage if you do not observe this chapter and the safety instructions in this documentation.

- ▶ Read this document thoroughly and completely before working with the product.
- ▶ Retain this document and ensure that it is available for all users at all times.
- ▶ Always include the necessary documentation when passing the equipment along to a third party.

2.2 Intended use

This product is a hydraulic component.

The device is an optical particle monitor, to monitor the cleanliness of fluids. It works according to the principle of light extinction (reduction of radiation) and measures particles in the fluid.

The measured values are converted to standardized cleanliness classes and shown on the display. Via different interfaces, the measurement data can be read out and transferred.

The connection to the fluid system is effected via two Minimesse®-connections M16x2.

You may use the product for the following:

- › Monitoring of cleanliness of a fluid
- › Trend analysis of the contamination degree

The product is intended for professional use only, not for private use.

"Intended use" also includes that you have completely read and understood this documentation, in particular Chapter 2 "Safety Instructions".

2.3 Improper use

Any other use than the intended use described, is improper and inadmissible.

If unsuitable products are installed or used in safety-related applications, unintended operating states can occur in the application, which can cause personal injury and / or material damage. Therefore only use this product in safety-related applications if this use is expressly specified and permitted in the product's documentation, e.g. in explosion protection areas or in safety-related parts of a control system (functional safety).

ARGO-HYTOS GmbH assumes no liability for damages resulting from improper use. The risks associated with improper use are solely with the user.

2.4 Reasonably foreseeable misuse

The delivery of the following media is forbidden:

- › Others than listed in Chapter 24.1 "Technical Data".

The operator alone is liable for damages resulting from improper use.

2.5 Qualification of personnel

The operations described in this document require fundamental knowledge of mechanics and hydraulics as well as knowledge of the appropriate technical terms. In order to ensure safe use, these operations may therefore only be carried out by a correspondingly skilled worker or an instructed person under the guidance of a skilled worker.

A skilled worker is someone who can - based on his / her technical education, knowledge and experience as well as knowledge of the respective regulations of the jobs assigned to him / her - recognize possible dangers and ensure appropriate safety measures. A skilled worker must observe the relevant technical regulations.

2.6 General safety instructions

- › Observe the valid regulations for accident prevention and environmental protection.
- › Observe the safety regulations and requirements of the country in which the product is used / applied.
- › Only use ARGO-HYTOS products that are in technically perfect condition.
- › Observe all instructions on the product.
- › People who assemble, operate, disassemble or maintain ARGO-HYTOS products may not do so under the influence of alcohol, other drugs or medications that affect the responsiveness.
- › Only use manufacturer-approved accessories and spare parts, in order to prevent personal danger due to unsuitable spare parts.
- › Observe the technical data and ambient specifications specified in the product documentation.
- › If unsuitable products are used or installed in safety-relevant applications, unintended operating states can occur in the application, which can cause personal injury and / or material damage. Therefore only use the product in safety-relevant applications if this use is expressly specified and permitted in the product's documentation.
- › You may only put the product into operation, when it has been established that the final product (e.g. a machine or system), into which the ARGO-HYTOS products are installed, complies with the country-specific regulations, safety regulations and standards of the application.

2.7 Product and technology related safety instructions



Laser

The OPCom Particle Monitor contains a laser sensor that is classified for intended use as a class 1 laser according to DIN EN 60825-1:2001-11. In reasonably foreseeable circumstances, the accessible laser radiation is not dangerous.

- ▶ With direct exposure to class 1 lasers in the upper power range, injury, such as blinding, impairment of color vision and disruption, cannot be ruled out.

2.8 Indications on the product

On the back of the device there is the nameplate (Fig. 1/1) and the note with the laser class (Fig. 1/2).



Fig. 1: Indication laser class

NOTE

Functional limitation

Damage of the pressure compensation membrane.
Impairment of protection class IP67.

On the back of the device there is a pressure compensation membrane (Fig. 1/3), which must not be damaged. Be careful while working on the backside.

On the side of the device, between a Minimes connection and the connector for the sensor cable, a label indicates the laser radiation.

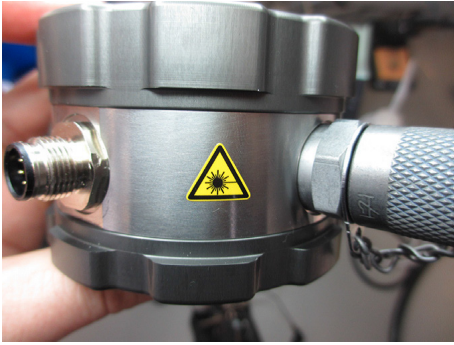

Fig. 2: Label laser radiation

For prevention of material damage and product damage



CAUTION

Danger due to improper handling!

Material damage!

- ▶ The OPCom Particle Monitor may only be used in accordance with Section 2-2, "Intended use".

Leakage or spillage of hydraulic fluid!

Environmental pollution and ground water pollution!

- ▶ Use oil binding agents in order to bind leaked hydraulic oil.

Contamination due to fluids and foreign bodies!

- ▶ Premature wear - malfunction - risk of damage - material damage
- ▶ Pay attention to cleanliness when assembling in order to prevent foreign bodies, such as welding beads or metal chips, from entering the hydraulic lines and leading to premature wear or malfunction.
- ▶ Make sure that connections, hydraulic lines and attachment parts (e.g. gauges) are free of dirt and chips.
- ▶ Check prior to commissioning that all hydraulic and mechanical connections are connected and tight, and that all gaskets and seals of the plug connectors are correctly assembled and undamaged.
- ▶ For removal of lubricants and other contaminants, use residue-free industrial wipes.
- ▶ Make sure that connections, hydraulic lines and attachment parts are clean.
- ▶ Ensure that no contaminants enter when closing the connections.
- ▶ Make sure that no detergents enter the hydraulic system.
- ▶ Do not use cotton waste or faying cleaning rags for cleaning.
- ▶ Do not use hemp as sealing agent.

4. Scope of delivery

The package includes:

- › 1 OPCom Particle Monitor
- › 1 Quick Start Guide

5. About this product

5.1 Functional description

The OPCom Particle Monitor is an optical particle monitor operating on the principle of light extinction.

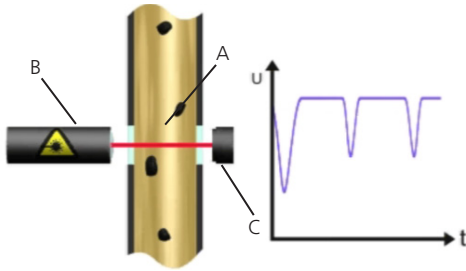

Fig. 3: Design and measuring principle of a particle monitor

It consists of a flowed measuring cell (A), a laser (B) and a photo diode (C).

The laser beams through the measuring cell to the opposite photo diode. If a particle passes through the laser beam, the light intensity detected by the photo diode is reduced. The larger the particle, the greater the reduction in intensity.

The OPCom Particle Monitor allows users to monitor the contamination level and the trend regarding cleanliness of fluids. Differences in absolute precision may arise compared to particle counters calibrated according to ISO 11171:99. However, the deviation is less than one scale number. Changes are shown with great precision.

Continuous monitoring of the cleanliness allows changes in the machine to be detected very quickly. Prompt warning allows measures to be taken before the contamination increases to the point of damaging the entire system.

5.2 Component overview



- 1 Hydraulic connection fluid
- 2 Front panel and display
- 3 Indicator light „Power“
- 4 Indicator light „Alarm“
- 5 Display
- 6 Hydraulic connection fluid
- 7 Selection button [←]
- 8 Button DOWN [▼]
- 9 Connection M12x1 sensor cable 1
- 10 Button UP [▲]

Fig. 4: Component overview

1 + 6 Hydraulic connection fluid

The device is equipped with two Minimesse®-Connectors M16x2. Usually two Minimesse® hoses are added to connect the particle monitor to the fluid system. The measurement is independent of the flow direction.

2 + 5 Front panel and display

The latest measured cleanliness classes and the time to the next measurement or the remaining measurement time is displayed.

3 Indicator light „Power“

If an operating voltage is applied, this indicator light glows green.

4 Indicator light „Alarm“

If there is an internal alarm, this indicator light glows red. Several alarms can be set in the device. Please read the manual for further information.

7 Selection button [←]

The selection button leads to the next menu level or to the next position if values are to be set.

8 Button DOWN [▼]

10 Button UP [▲]

These buttons navigate through the menu and browse through entries.

9 Connection M12x1 sensor cable

The device is equipped with an 8 pole M12x1 connector for connection of a sensor cable. The pin assignment of the sensor cable and its connection are included in this manual.

Further functions of the buttons:

› Back:

Simultaneous pressing of the buttons UP [▲] and DOWN [▼].

› Changing of values:

With the button UP [▲] or the button DOWN [▼] the required parameter can be marked in the menu structure. To choose this parameter press the selection button, then the value can be changed with the UP [▲] or DOWN [▼] button. Changes are confirmed by pressing the selection button after the last position of input ability. In case of a jump to the higher level before pressing the selection button, the changes will not be saved.

5.3 Identification of the product

www.argo-hytos.com

Made in Germany

Typ: OPCOM II

Mat.-Nr.: 27395401

CANopen Node ID:

Baud Rate: 250KB/s

**ARGO
HYTOS**

9..33V max. 0,3A

max. 420bar

CE

IP67

>Barcode Data Serial#<

Fig. 5: Nameplate

There are no special transport instructions for this product.

- ▶ However, observe the instructions in Chapter 2, "Safety instructions".
- ▶ For storage and transport, observe the specified environmental conditions stated in the technical data.

7.1 Operating site

Please follow these instructions when determining the mounting location:

- › Connect the particle monitor in bypass flow to a pressure line.
- › The flow direction is arbitrary.
- › At the connection point there should preferably be constant pressure conditions. The pressure may vary, but there must not be pressure peaks or strong fluctuations.
- › The volume flow must be constant and be between 50 and 400 ml/min.
- › A flow control or pressure reduction must always be installed downstream of the particle monitor, since these can generate turbulences or air bubbles which cause measurement errors.
- › If a pump is needed to generate the required flow, this should be a low pulsation pump which should be installed in the pressure line since negative pressure on the suction side can lead to air bubbles which would cause measurement errors.
- › If air bubbles occur in the system, a calming section in form of a hose of approx. 2 meters should be installed ahead of the sensor.

7.2 Hydraulic connection

The sensor has two ¼"-screw connections and is delivered from the factory with screwed Minimesh connections. The system pressure generates the required flow rate and needs to be throttled after the device. The flow direction can be chosen freely.

To be able to read the display and use the keyboard, the device should be installed at an accessible position. With the length of the hoses, the risk of settling of larger particles increases. Furthermore, especially at higher viscosities and when using Minimesh hoses, it must be ensured that the pressure is sufficiently high to generate a flow between 50 and 400 ml/min.



The Minimesh connections can be exchanged by other connectors. A maximum tightening torque of 25 Nm shall not be exceeded.



While exchanging the connection couplings, no dirt, chips or other contaminations shall enter the interior of the device.

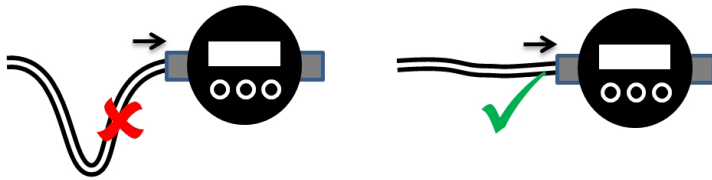

Fig. 6: Hydraulic connection, avoid blind holes in the supply line

The device should be installed at a relevant measurement location in the hydraulic circuit where constant pressure conditions exist.

The pressure may vary, but it must not show any peaks or strong fluctuations during the measurement.

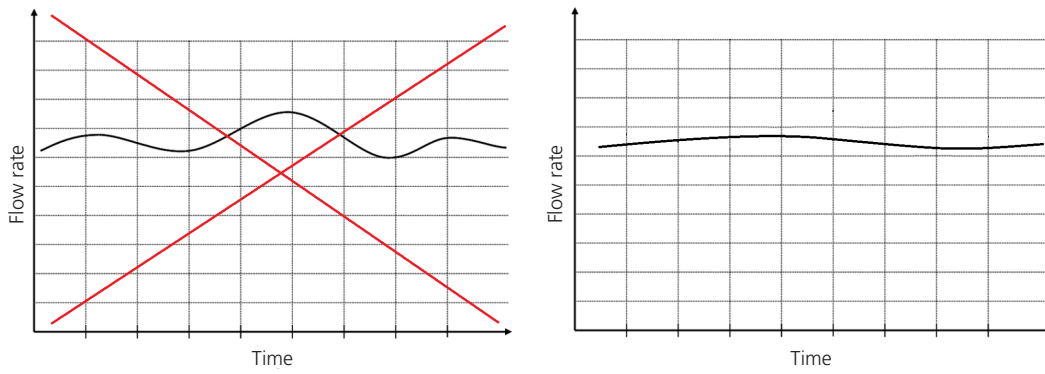

Fig. 7: Boundary conditons flow rate



Connection to the control line is recommended. Usually, only moderate pressures prevail at this point and a discharge of a maximum of 400 ml/min does normally not represent a problem for the control circuit. If there is no control circuit, the filter-/cooling circuit often is a possible alternative.

In the following figure the pressure difference depending on the volume flow is displayed for several viscosities. With a given volume flow, the required pressure can be estimated.

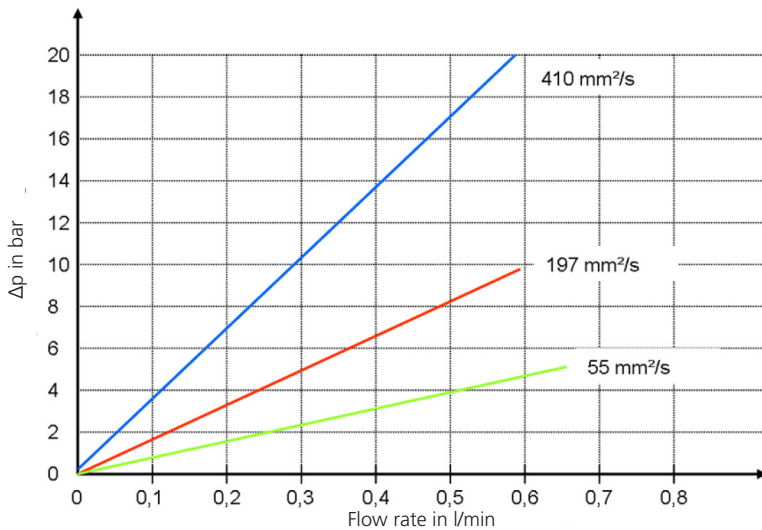

Fig. 8: Δp-Q characteristics for varying viscosities without Minimes connections

7.3 Mounting

The device has two options for mounting:

Orientation	Mounting	Tightening torque	Screw depth
Bottom	4 x M5	Max. 4 Nm (strength class 8.8)	Min. 5 ⁺¹ mm
Laterally	2 x M6	Max. 8 Nm (strength class 8.8)	Min. 6 ⁺¹ mm

Table 6: Mounting options

7.4 Mechanical stress

The mechanical stress on the device must not exceed the data given in the table below.

Stress	Frequency	Stress
Max. vibration in all three axes	5 ...9 Hz 9 ...16,5 Hz 16,5 ...200 Hz	Amplitude: +/-15 mm 3 g 10 g

Table 7: Permitted mechanical stress



Fig. 9: Inadmissible mechanical stress

8. Electrical connection



WARNING

Incorrect power supply
Danger to life – risk of injury

- ▶ Only a qualified electrician should install the device.
- ▶ Comply with national and international guidelines for setting up electrical equipment.

Power supply in accordance with EN50178, SELV, PELV, VDE0100-410/A1.
De-energize the system for installation and connect the device as follows:
A shielded sensor cable must be used.

8.1 Pin assignment (view from above)

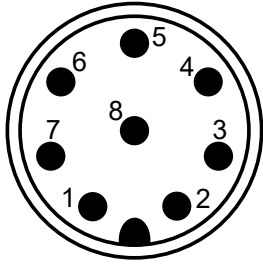

Fig. 10: Pin assignment of the sensor connector

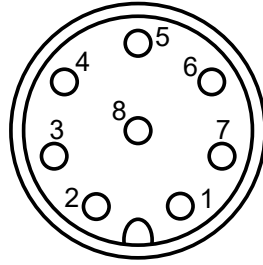

Fig. 11: Pin assignment of the cable connector

Pin	Function	Color standard cable
1	Power supply L+	White
2	Power supply L-	Brown
3	TxD, CAN low [OUT]	Green
4	RxD, CAN high [IN]	Yellow
5	Digital input (start/stop)	Grey
6	Analog output 4...20mA	Rose
7	Switch output (open collector/alarm)	Blue
8	Signal ground	Red
Shield	-	-

Table 8: Pin assignment

The sensor cable must be shielded. To achieve IP67 degree of protection, only suitable connectors and cables must be used. The tightening torque for the connector is 0.1 Nm.

9.1 Before commissioning

Be sure to read and understand the operating manual before putting the device into operation.

- ▶ The information for intended use, the operating conditions and the technical specifications must be adhered to.
- ▶ Attach the particle monitor according to chapter 7 "Assembly".
- ▶ Cables and hoses must be outside of the movement range of the operating personnel (tripping hazard).

10. Start screen

The condition of the device is visible on the start screen.

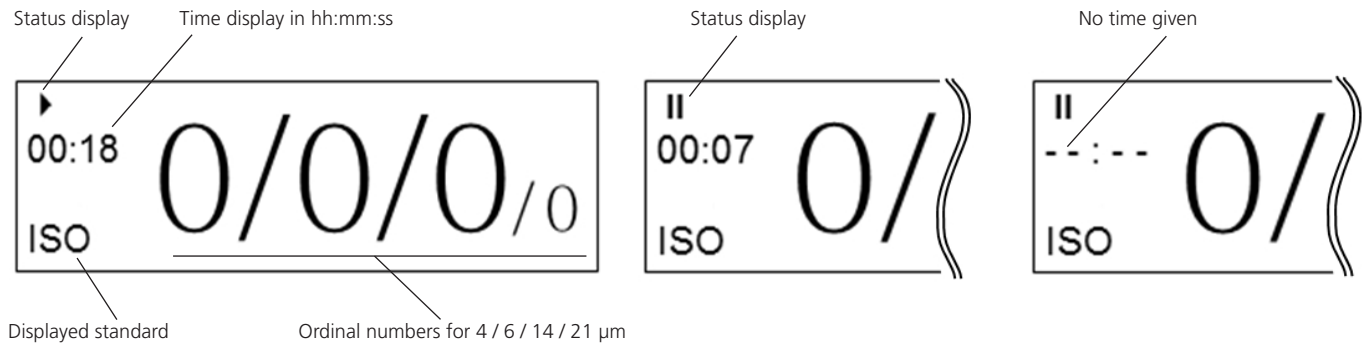

Fig. 12: Start screen, running and paused measurement, no time given

10.1 Status display

- › Running measurement ▶
- › Regulating laser ▶ (flashing) at the start of each measurement for 2 to 3 seconds
- › Device in pause mode ||

10.2 Time display

- › Running measurement:
Displays - depending on the operating mode - the elapsed or remaining time for the present measurement.
Specified in [minutes: seconds]
- › Pause mode:
Indicates the remaining time to the next measurement in [minutes: seconds]
- › If the pause time is changed within the pause mode and it is less than the already elapsed time, the display shows „- - : - -“.
The information will remain in place until the original remaining time runs out. Thereafter, the new pause time is active.

10.3 Displayed standard

Indication of the currently displayed standard: ISO, SAE, NAS or GOST. The selection is made via the menu.

10.4 Ordinal numbers

Display of the ordinal numbers of the last done measurement. The amount of ordinal numbers may differ according to the selected standard. For the standards GOST and NAS only one ordinal number is displayed.



Ordinal numbers according to ISO 4406 between 1 and 6 are always displayed with ≤ 6 .

According to ISO 4406 the ordinal number for the 21 μm measuring channel is not evaluated. This measured value is, however, shown as additional information and indicated by a reduced size.

The [▲] or [▼] buttons are used to navigate in the menu and to scroll through the entries. Press the select button [↵] to jump to the next level. Go back by pressing the [▲] and [▼] button simultaneously.

If you need to make adjustments to values, you can jump to the next position by pressing the [↵] button.

Select the number to change, and change it using the arrow keys [▲] and [▼]. The changes are only accepted once you confirm using [↵] after the last position.

If you jump to a higher level before final confirmation, the changes will be rejected.

11.1 Menu structure

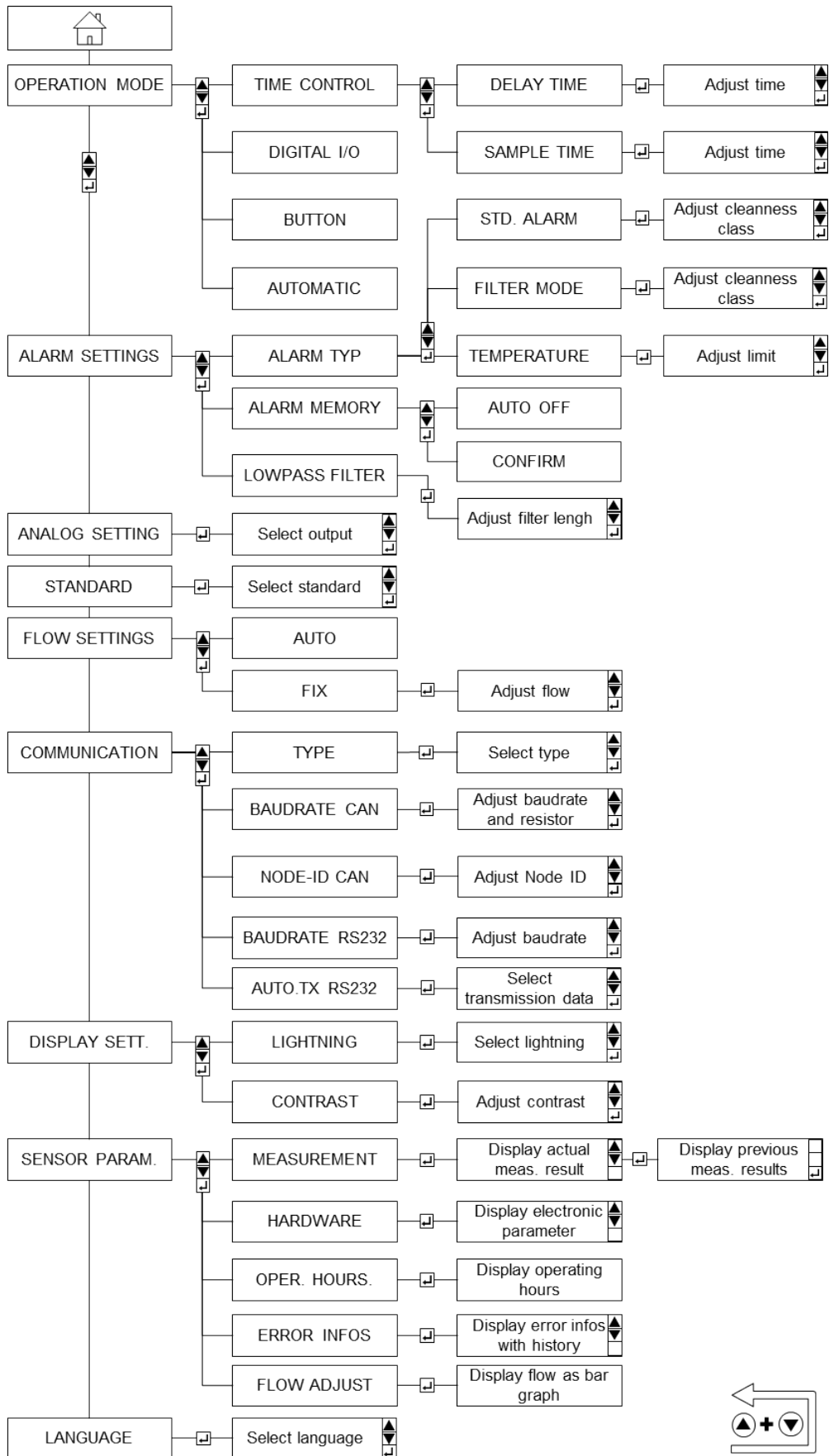

Fig. 13: Menu structure

11.2 Operating modes

Four operating modes are available, which can be specified in the menu.

At the beginning of a measurement the internal laser adjusts automatically. This process can be seen by the flashing of the symbol [▶] on the screen and usually takes about 2 to 3 seconds. Thereafter, the symbol lights up permanently and measurement starts. The pause mode is shown by the symbol [II].



Measuring times between 30 and 300 seconds need to be observed. For cleanliness of 15 (at 4µm(c)) and better (according to ISO 4406:17), the measuring time should be at least 120 seconds. Standard setting for the measuring time is 60 seconds.

11.2.1 Time-controlled measurement

The OPCom Particle Monitor works with the set measuring time and pause times between measurements. The following settings are to be observed:

Parameter	Min. value / seconds	Max. value / seconds
Measuring time	30	300
Pause time	1	86400 (24h)
Factory setting measuring time	60	
Factory setting pause time	10	

Table 9: Parameters time-controlled measurement

The standard setting of 60 seconds measuring time and 10 seconds pause time, provides a new measurement result every 70 seconds.

Information regarding time specification on the start screen:

- › Running measurement: Time remaining to the end of measurement (down counter)
- › Pause modus: Time remaining to the next measurement (down counter)

11.2.2 Digital I/O

A measurement is in progress [▶], as long as Pin 5 of the M12 plug is placed on the supply voltage (L+) or is not connected. If Pin 5 is connected to the ground (L-, Pin 2), the pause mode [II] is active.

The maximum input current at Pin 5 is 10mA.

Information regarding time specification on the start screen:

- › Running measurement: Elapsed time (up counter)
- › Pause mode: Displays the measuring time of the last measurement (static display)

Assignment pin 5	Function
Supply voltage (L+)	Running measurement [▶]
Not connected	Running measurement [▶]
Ground (L-, Pin 2)	Pause mode [II]

Table 10: Assignment Pin 5 for measuring mode I/O

11.2.3 Button

There are two ways to start or finish a measurement.

- › By manual pressing of the button [←].
- › By a "Start" and "Stop" command via the digital communication line.
This can be done via RS232, CANopen or CAN J1939.

After the end of a measurement, the measuring result is shown on the start screen. The compliance with the recommended measuring times needs to be ensured.

Information regarding time specification on the start screen:

- › Running measurement: Elapsed time (up counter)
- › Pause mode: Displays the measuring time of the last measurement (static display)

11.2.4 Automatic

In automatic mode, the measuring time is dynamic, dependent on the flow and the particle concentration.

A measurement runs until the following conditions are met:

- › A defined number of particle has been detected AND
- › The measuring time is at least 45 seconds OR
- › The measuring time exceeds 300 seconds

After the compliance of the conditions the result is calculated and displayed. The number of necessary particles can be changed via the serial interface with the command "WAutoParts". For further information see chapter "Communication". It should however only be changed by an experienced user. Factory setting is 200.

Information regarding time specification on the start screen:

- › Running measurement: Elapsed time (up counter)
- › Pause mode: Not available, a new measurement is started automatically.

11.3 Alarm configuration

11.3.1 Alarm type

There are three different alarm modes available, which can be specified in the menu.

All three alarms are connected with each other. If one of the three alarms is activated, this is signaled by the following:

- › LED "Alarm" lights up red
- › A flashing warning triangle with an exclamation mark in the display
- › Alarm output Pin 7 active (see Chapter 15.2 "Switch output")
- › Setting of defined bits in the error codes (ERC)



Measurement results of 0 (ZERO) are considered to be implausible.
The alarm handling is ignored in this case, apart from the temperature alarm.

11.3.1.1 Standard alarm

For each measured ordinal number (OL), a separate limit value can be set. If one size class shall not be considered, the smallest value must be set. The alarm is activated as soon as a measured cleanliness class has reached or exceeded the set limit value.

Standard	Adjustment range	Value for deactivation	Alarm condition
ISO 4406:17	0, 1, 2... 28	0	OZ 4 µm ≥ limit value OR OZ 6 µm ≥ limit value OR OZ 14 µm ≥ limit value OR OZ 21 µm ≥ limit value
SAE AS 4059E	000, 00, 0, 1, 2...12	000	
NAS 1638	00, 0, 1, 2...12	00	OZ ≥ limit value
GOST 17216	00, 0, 1, 2...17	00	

Table 11: Alarm configuration standard

11.3.1.2 Filter mode

For each measured ordinal number (OL) a separate limit value can be set. If one size class shall not be considered the smallest value must be set. The alarm is activated as soon as a measured cleanliness class has reached or has fallen below the set limit value.

Standard	Adjustment range	Value for deactivation	Alarm condition
ISO 4406:17	0, 1, 2... 28	0	OZ 4 µm ≥ limit value OR OZ 6 µm ≥ limit value OR OZ 14 µm ≥ limit value OR OZ 21 µm ≥ limit value
SAE AS 4059E	000, 00, 0, 1, 2...12	000	
NAS 1638	00, 0, 1, 2...12	00	OZ ≥ limit value
GOST 17216	00, 0, 1, 2...17	00	

Table 12: Alarm configuration filter mode

11.3.1.3 Temperature alarm



Only available from software version 2.00.15.

Here, a limit value for the temperature can be set. The temperature alarm is active when the limit value has been reached or exceeded. To deactivate the alarm, the limit value has to be set to "00".

The measured temperature does not directly correspond to the temperature of the oil.

Adjustment range: 00...85 (00=deactivated)

11.3.2 Alarm memory

There are two possibilities to remove a signaled alarm. The setting can be made in the menu.

1. Automatic off

If the conditions for an alarm are not fulfilled anymore, the alarm is removed automatically.

2. Confirm

The alarm continues to be displayed, even if the conditions for an alarm are no longer met. It will continue to be displayed until it is removed manually.

The alarm can be removed by pressing the UP [▲] and DOWN [▼] button simultaneously.

11.3.3 Low-pass filter

In a hydraulic system short-term increases in concentration (peaks) may arise, which are not representative for the overall system, e.g. by operating a manual valve. The OPCOM detects these changes and displays them correctly.

The low-pass filter ensures that when an alarm is set according to chapter 12.3.1.1 and 12.3.1.2, it is not triggered at each peak. The relevant particle concentration for the alarm is smoothed internally and an alarm is only issued at a sustained change in measurement. The output and display of the measured values are not affected by the filtering.

- › At a volume flow of 0 ml/min or an ISO class of 0 at 4 µm, the filter function is automatically deactivated.
- › Adjustment range: 1...255 (1=deactivated)
- › Factory setting: 2
- › Recommended value: ≤10

The following diagram shows a step response for various values of the low-pass filter. The table shows how many measurements have to be carried out, so that the internal concentration for alarm evaluation reaches 90% of the actual measured concentration.

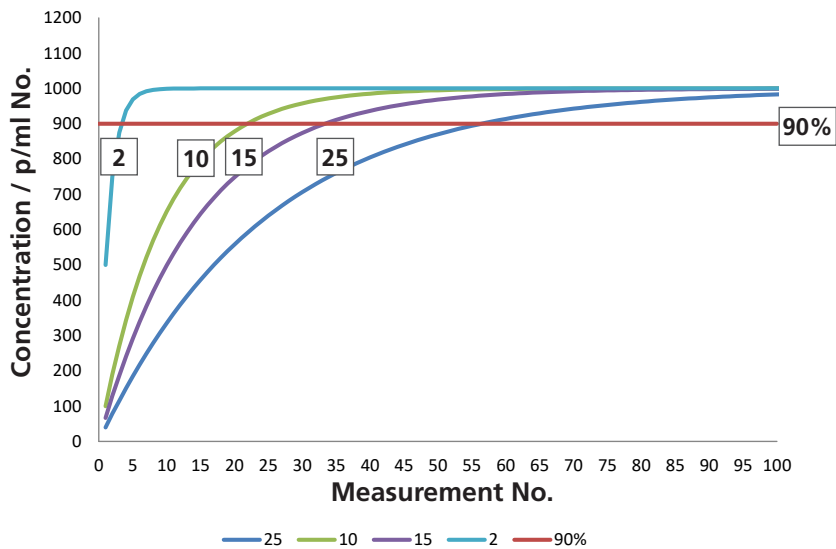

Fig 14: Step response for low-pass filter values 2, 10, 15 and 25

Low-pass filter value	2	5	10	15	25	50	100
Number of measurements up to 90%	3	10	21	33	56	113	229

Table 13: Low-pass filter values to reach the 90% threshold.

11.4 Configuration analog

The measurement results can be transmitted via the analog current output (4...20 mA). The following table provides an overview of possible configurations. For the measurement of the current and the conversions see chapter 14 "Analog current output (4...20 mA)".

Menu selection	Analog current output
4 μm	Static output of the ordinal number for 4 μm , depending on the set standard ISO or SAE
6 μm	Static output of the ordinal number for 6 μm , depending on the set standard ISO or SAE
14 μm	Static output of the ordinal number for 14 μm , depending on the set standard ISO or SAE
21 μm	Static output of the ordinal number for 21 μm , depending on the set standard ISO or SAE
SEQUENTIAL (Standard)	Static output of the ordinal number for 4, 6, 14 and 21 μm , depending on the set standard ISO or SAE
NAS 1638	Output independent from the set standard. ISO, SAE and GOST can be shown on the display, NAS is however issued via the analog current output.
GOST 17216	Output independent from the set standard. ISO, SAE and NAS can be shown on the display, GOST is however issued via the analog current output.

Table 14: Configuration of the analog current output

11.5 Standard

The display of cleanliness can be chosen according to one of the following standards:

- › ISO 4406:17
- › SAE AS 4059E
- › NAS 1638
- › GOST 17216



NAS and GOST are only available from software version 2.00.15.

It has to be considered that for SAE AS 4059E the sizes 38 and 70µm are not analyzed in separate channels.

The setting only applies to the display on the start screen. In the internal memory and on the issue via digital interfaces (CAN or RS232) all standards are visible.

Which standard is selected, can be seen on the start screen, bottom left.

11.6 Configuration flow

11.6.1 Automatic

In addition to the particle size and number of particles, the OPCom Particle Monitor also calculates a volume flow index to be able to evaluate the particle concentration.



The calculated flow rate index is not an exact measurement of the volume flow. It is an internal calculation value, which may be used as an indicator during installation and commissioning of the unit. The device should not be viewed or used as a flow meter.

11.6.2 Fix

The particle concentration is then calculated, starting from the fixed set flow rate. The value is to be entered in ml/min.

It is important to ensure that the actual and the fixed flow may not differ significantly. Otherwise, the calculated particle concentration is not correct.

11.7 Communication

There are several possible settings, which can be specified in the menu.

11.7.1 Type

Here you can choose how the digital interface is configured. Only one type can be chosen. The physical connection is always the same.

The following types are available:

- › RS 232
- › CANopen
- › CAN J1939
- › AUTO CANOPEN (factory setting)
- › AUTO J1939



CAN J1939 is only available from software version 2.00.15.

The setting will be active after a restart of the device.

When selecting "AUTO", the type is determined by the physical voltage level at the digital interface. The automatic determination of the type (RS232 or CAN) is done when the device is turned on.

CANopen and CAN J1939 are operated with the same physical voltage levels. If "CAN" is detected, the CANopen protocol is activated (factory setting). If J1939 shall be used, "AUTO J1939" has to be activated. For further information see chapter 16.3 "Configuration".

11.8 Baud rate CAN

The baud rate describes the transmission speed for the CANopen and the CAN J1939 protocol. The physical unit is kilobits per second.

The following settings are available:

- › 125 BAUD
- › 250K BAUD
- › 500K BAUD
- › 1000K BAUD
- › TERM. CAN

With the activation of „TERM. CAN“, the transmission line in the device will be completed with a terminating resistor of 120 Ohm.

11.8.1 Node ID CAN

The Node ID is the address, with which the device can be addressed via the CAN bus. The Node ID is required for CANopen and CAN J1939 protocol.

Setting range: 1 ... 127 (decimal)

Factory setting: 10 (decimal)

11.8.2 Baud rate RS232

The baud rate describes the transmission speed for the RS232 protocol. The physical unit is byte per second.

The following settings are available:

- › 9600 BAUD
- › 19200 BAUD
- › 57600 BAUD (Transmission speed for firmware updates)
- › 115200 BAUD

If the device is connected via RS232 interface, the parent instance must always be operated with the same baud rate.

11.8.3 Automatic transmission

With the activation of the automatic transmission, the measurement results are transmitted via RS232 interface immediately after a measurement. The transmitted data string corresponds to the response to the command "RVal". For further information see chapter 16.2 "Read commands".

Example for a data string:

```
$Time:78.8916[h];ISO4um:0[-];ISO6um:0[-];ISO14um:0[-];ISO21um:0[-];SAE4um:000[-];  
SAE6um:000[-];SAE14um:000[-];SAE21um:000[-];NAS:00[-];GOST:00[-];Conc4um:0.00[p/ml];  
Conc6um:0.00[p/ml];Conc14um:0.00[p/ml];Conc21um:0.00[p/ml]; FIndex:50000[-];MTime:60[s];  
ERC1:0x0000;ERC2:0x0000;ERC3:0x0000;ERC4:0x0800;CRC:Ä
```

11.9 Configuration display

For the display, various setting options are available.

- › Lighting:
Selection, whether the backlight should be permanently active or is deactivated automatically after 10 seconds.
- › Contrast:
Adjusting the contrast via a bar display.
UP button [▲] = increase contrast
DOWN button [▼] = reduce contrast
Confirmation via enter key [↵]

11.10 Sensor parameter

11.10.1 Measurement results

Representation of the results of the last valid measurements. With the UP [▲] and DOWN [▼] button all results are displayed to one measurement. With the enter key [↵] the previous measurement results can be displayed again.

The representation of the ordinal numbers varies with the selection of the standard.

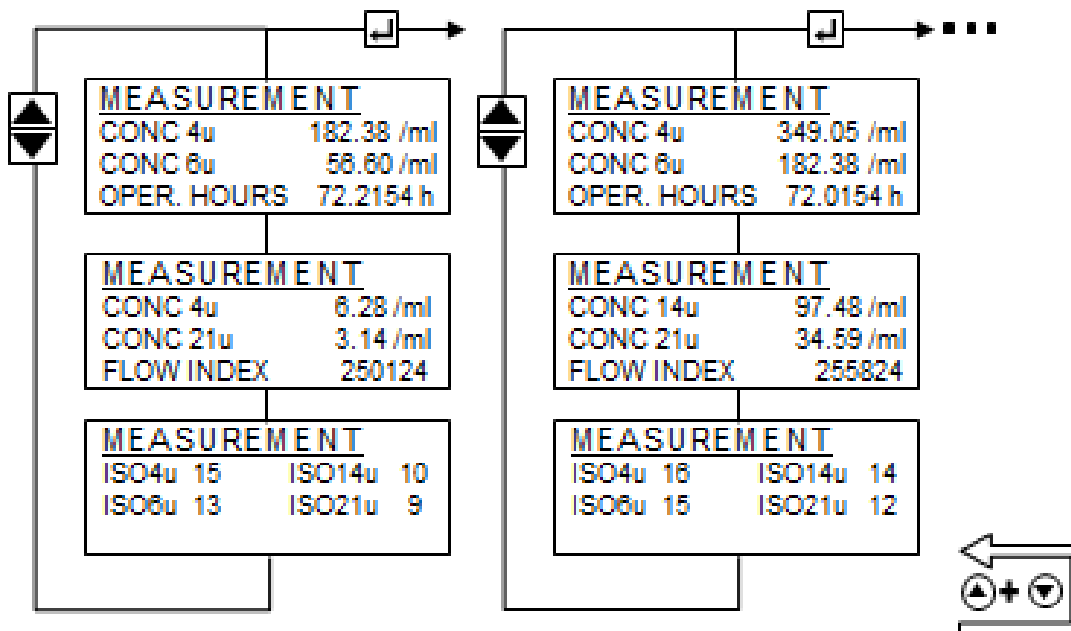

Fig. 15: Measurement results and display of history

11.10.2 Electronics

Representation of internal sensor parameters. The user has no influence thereon.

- › Laser current:
The current which operates the internal laser. The value should be between 1 and 2.8mA. If the value is out of range, there is a risk of malfunction. See chapter 21.
- › PD voltage:
Voltage of the internal detector. The value should be between 3.7 and 4.3 V. If the value is out of range, there is a risk of malfunction. See chapter 21.
- › Temperature:
Internal electronics temperature. The displayed value does not directly correspond to the temperature of the oil.
- › Reinforcement:
Adjusted amount for the internal detector.

11.10.3 Operating hours

- › Sensor:
Counter of operating hours of the device. The counter is active as soon as the device is powered.
- › Laser:
Counter of operating hours of the laser. This counter is only active during a measurement.
- › Hour scale:
Display of the remaining hours until the next calibration of the device. At a value of 0 (ZERO), the time has expired or the function is not activated. When the time has elapsed, this is indicated by a message on the start screen.

11.10.4 Error info

The OPCom Particle Monitor collects various errors, information and operating status and summarizes them into four 16 bit values, the ERC (Error Code). These are always shown in hexadecimal notation. For further information on the decoding see Chapter 25.2 "Coding of error bits".

The ERCs are created and stored after each measurement. In the display the last 256 ERCs are shown. To go through them use the UP [▲] and DOWN [▼] buttons.

To match the ERCs with the specific measurement, the referring operating hour is displayed it the upper right corner.

- › 1/256 = ERC of the latest valid measurement
- › 256/256 = ERC of the oldest valid measurement

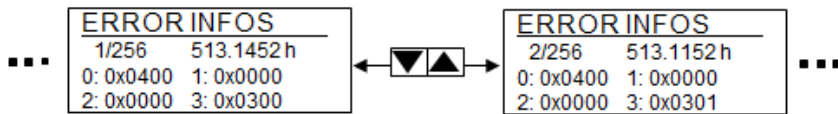

Fig. 16: Display of error codes (ERC)

11.10.5 Flow settings

If the flow is automatically determined, this is shown via a bar graph. The bar is scaled from 50 to 400 ml/min. The representation is used for checking the correct flow during commissioning. The display is updated every 10 seconds.

The flashing letters L (Low) or H (High) signalize a fall below or a rise above the threshold and must be avoided.

If the flow is fixed to a static value, this is also displayed. Then the bar does not change.

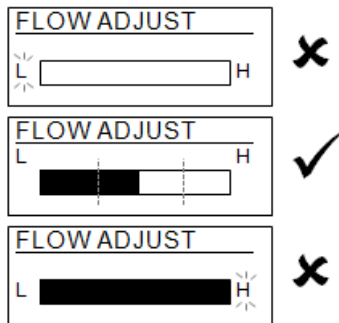

Fig. 17: Bar display of flow

11.11 Language

The menu can be displayed in different languages. The following languages are available:

- › English
- › German
- › French
- › Dutch
- › Czech
- › Spanish
- › Italian
- › Portuguese
- › Polish
- › Turkish

The instrument is calibrated in accordance with ISO 11943.

The equipment used for the calibration is primary calibrated in accordance with ISO 11171 and therefore traceable to NIST SRM 2806A.



The sign μm (c) indicates the particle size calibration using ISOMTD test dust.

The calibration certificate for initial calibration is valid for 18 months. Each subsequent certificate is valid for 12 months.

12.1 Calibration note



This function is only available from software version 2.00.15 and is deactivated ex works.

A necessary calibration is signaled through a message on the display. See the following figure. The device is still fully operable and provides measurement results. The message can be acknowledged by pressing the enter key [↵] for 2 seconds.

From this point, the message reappears after 500 / 800 and 900 hours. The device is still fully operable and provides measurement results. The message can be acknowledged by pressing the enter key [↵] for 2 seconds.

After 1000 hours, the message flashes every 2 seconds. The device is still fully operable and provides measurement results. An acknowledgement is not possible.

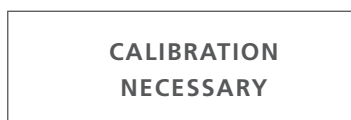

Fig. 18: Display message calibration note



Resetting the calibration note on the display can only be carried out by ARGO-HYTOS service.

The remaining hours until the appearance of the first message can be retrieved in the device menu under "SENSORPARAM > BETRIEBSSTD" ("HOURSCALE").

13. Analog current output (4...20mA)

13.1 Measurement without load resistance

The measurement of the current should be carried out with a suitable ammeter.

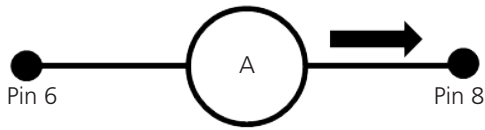

Fig. 19: Measurement of the current without load resistance

The ordinal numbers for the various standards are calculated according to the tables in chapter 13.

13.2 Measurement with load resistance

The measurement of the voltage should be carried out with a suitable voltmeter.

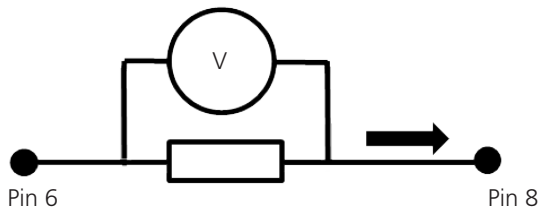

Fig. 20: Measurement of the current with load resistance

The ordinal numbers for the various standards are calculated according to the tables in chapter 13.

The load resistance cannot be chosen arbitrarily. It has to be adjusted according to the supply voltage. The maximal load resistance can be calculated with the following formula:

$$R_{\max} / \Omega = \frac{U / V - 2V}{20\text{mA}} \cdot 100 \Omega$$

Alternatively, the following table may be employed:

R_{\max} / Ω	Supply voltage / V
250	9
400	12
1000	24

Table 15: Maximum load resistance

13.3 Configuration

The choice which ordinal number and which standard shall be given out through the analog output can be done in the menu of the device under "CONFIG. ANALOG".

13.4 Conversion of the analog current output to the ordinal number

The analog current output gives a signal from 4 to 20 mA. Below, the conversions to the respective ordinal number are described.

I/mA	ISO 4406:17	SAE AS 4059E
4	0	000
12	13	5
20	26	12

Table 16: Comparison table current output to ordinal number ISO and SAE

I/mA	NAS 1638	GOST 17216
4	00	00
12	7	15
13	8	17
14	9	-
15	10	-
16	11	-
17	12	-
20	-	-

Table 17: Comparison table current output to ordinal number NAS and GOST

Standard	Formula ordinal number
ISO 4406:17	$1,625 \cdot I / \text{mA} - 6,5$
SAE AS 4059 E	$0,875 \cdot I / \text{mA} - 5,5$
NAS 1638	$I / \text{mA} - 5$
GOST 17216	$2 \cdot I / \text{mA} - 9$

Table 18: Conversion ordinal numbers



NAS and GOST are only available from software version 2.00.15.

13.5 Sequential data output for ISO 4406:17 and SAE AS 4059E

For the standards ISO 4406:17 and SAE AS 4059E, the function of the analog sequential data output may be used. The four ordinal numbers are successively output in a predetermined time frame via the analog interface (4...20 MA).

Each sequence starts with a 20 mA signal for 4 seconds. The following figure shows a complete output sequence with the start character.

For NAS and GOST no sequential output is available.

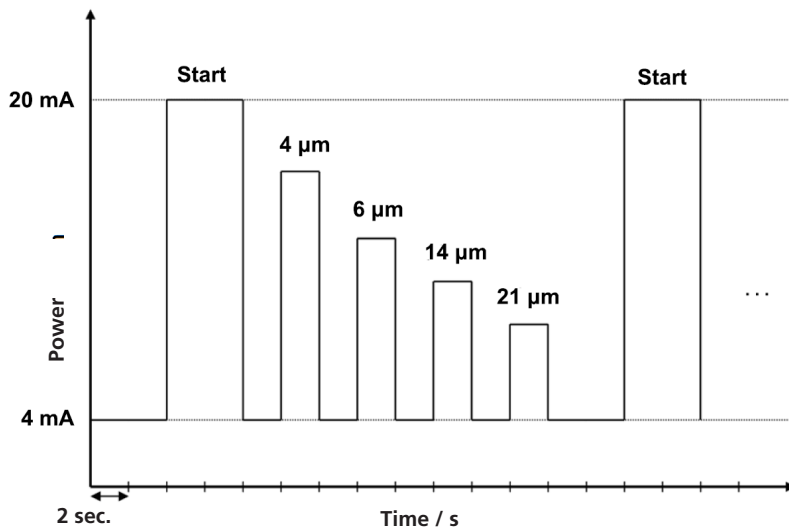

Fig. 21: Sequential data output

14. Switching inputs and outputs

14.1 Digital input

The digital input is needed for the measuring mode: Digital I/O. To start and stop a measurement, pin 5 has to be set either to L- or L+. For further information see Chapter 12.2.2 Digital I/O.

14.2 Switching output

The appearance of an alarm can be detected next to the red LED and the warning triangle on the display on the alarm output at pin 7. See Chapter 12.3 "Configuration alarm".

Two options are available.



Pin 7 is not a switch in the sense of a turnkey.

Depending on the state of alarm, pin 7 is on the ground (L-) or it is not connected (floating).

14.2.1 Option 1

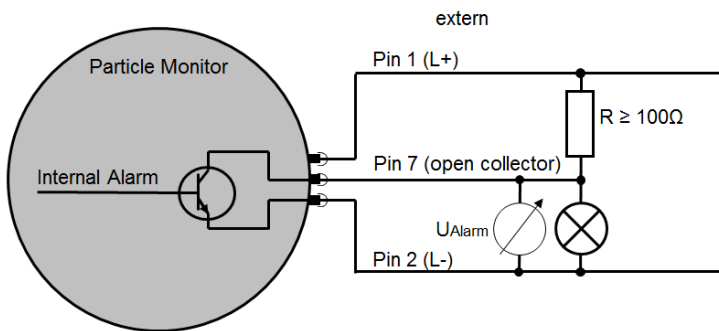

Fig. 22: Connection diagram switching output option 1

Alarm	Statement	Voltage measurement	When connecting a consumer
Available (true)	The internal transistor connects pin 7 to pin 2. The resistor R now prevents a direct short circuit between pin 1 (L+) and pin 2 (L-).	$U_{\text{Alarm}} = L- = 0V$ $R = 1 \dots 10K\Omega$	 $R \geq 100\Omega$
Missing (false)	Pin 7 is not connected (floating).	$U_{\text{Alarm}} = L+$ $R = 1 \dots 10K\Omega$	 $R \geq 100\Omega$

Table 19: Switching behavior of switching output option 1

14.2.2 Option 2

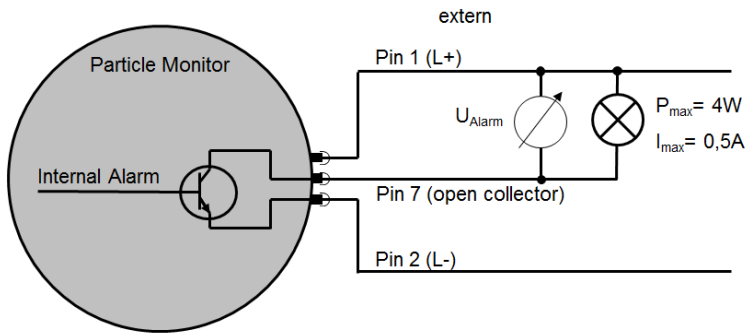

Fig. 23: Connection diagram switching output option 2

Alarm	Statement	Voltage measurement	When connecting a consumer
Available (true)	The internal transistor connects pin 7 to pin 2. The voltage is measured against L-.	$U_{\text{Alarm}} = L+$	 $P_{\text{max}} = 4 \text{ W}$ $I_{\text{max}} = 0,5 \text{ A}$
Missing (false)	Pin 7 is not connected (floating).	$U_{\text{Alarm}} = L- = 0 \text{ V}$	 $P_{\text{max}} = 4 \text{ W}$ $I_{\text{max}} = 0,5 \text{ A}$

Table 20: Switching behavior of switching output option 2

The OPCom Particle Monitor has a serial interface, via which it can be read out and configured. For this purpose, a PC and an appropriate terminal program or a readout software is needed. The sensor has to be connected to a free COM port of a computer. A suitable communication cable for serial connection between sensor and computer / controller is described in Chapter 21 "Accessories". If the computer does not have a serial COM port, it is possible to use a USB-serial converter.

15.1 Interface parameters

- › Baud rate: 9600 (Standard) / 19200 / 57600 / 115200
- › Data-Bits: 8
- › Parity: None
- › Stop-Bits: 1
- › Flow control: None

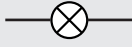
15.2 Read commands

#	Instruction format	Meaning	Return format
1	RVal[CR]	Reading of the current measurement values	\$Time:%.4f[h]; ISO4um:%d[-]; ISO6um:%d[-]; ISO14um:%d[-]; ISO21um:%d[-]; SAE4um:%c[-]; SAE6um:%c[-]; SAE14um:%c[-]; SAE21um:%c[-]; NAS:%c[-]; GOST:%c[-]; Conc4um:%.2f[p/ml]; Conc6um:%.2f[p/ml]; Conc14um:%.2f[p/ml]; Conc21um:%.2f[p/ml]; Flindex:%d[-]; MTime:%d[s]; ERC1:0x0000; ERC2:0x0000; ERC3:0x0000; ERC4:0x0300; CRC:z[CR][LF]
2	RID[CR]	Reading of the identification	\$Argo-Hytos; OPCom II; SN:xxxxxx; SW:xx.xx.xx; CRC:z[CR][LF]
3	RCon[CR]	Reading of the current configuration: Standard Operating mode Flow Analog output Alarm Mode Filter setting Alarm value ISO/SAE 4µm Alarm value ISO/SAE 6µm Alarm value ISO/SAE 14µm Alarm value ISO/SAE 21µm Alarm value NAS Alarm value GOST Alarm value temperature Measuring time Pause time Checksum	\$Std:%d; StartMode:%d; Flow:%d; AO1:%d; Amode:%d; Mean:%d; Alarm4:%c; Alarm6:%c; Alarm14:%c; Alarm21:%c; AlarmNAS:%c; AlarmGOST:%c; AlarmT:%d[°C]; Mtime:%d[s]; Htime:%d[s]; CRC:z[CR][LF]

#	Instruction format	Meaning	Return format
4	RMemS[CR]	Number max. records in memory	MemS:%d[-];CRC:z[CR][LF]
5	RMemU[CR]	Number of current records in memory	MemU:%d[-];CRC:z[CR][LF]
6	RMemO[CR]	Memory organization:	Time; ISO4um; ISO6um; ISO14um; ISO21um; SAE4um; SAE6um; SAE14um; SAE21um; NAS; GOST; Conc4um; Conc6um; Conc14um; Conc21um; FIndex; MTime; ERC1; ERC2; ERC3; ERC4[CR][LF]
7	RMem[CR]	Reading of all records in memory preceded by memory organization. Oldest record first. Quit with enter key.	[memory organization] %f;%f; ... 0x0000[CR][LF] ... %f;%f; ... 0x0000[CR][LF] finished[CR][LF]
8	RMem-n[CR]	Reading of the last n-records in memory. With subsequent checksum (CRC) per record. Oldest record first. Quit with enter key.	\$\$f;%f; ... 0x0000;CRC:z[CR][LF] ... \$\$f;%f; ... 0x0000;CRC:z[CR][LF] finished[CR][LF]
9	RMemn;i[CR]	Reading of the i-records starting with the records in memory. Oldest record = Record 0 → n=0. With subsequent checksum (CRC) per record. Oldest record first. Quit with enter key.	\$\$f;%f; ... 0x0000;CRC:z[CR][LF] ... \$\$f;%f; ... 0x0000;CRC:z[CR][LF] finished[CR][LF]
10	RMemH-n[CR]	Reading of records of the last n-hours in memory. Oldest record first. Quit with enter key.	\$\$f;%f; ... 0x0000;CRC:z[CR][LF] ... \$\$f;%f; ... 0x0000;CRC:z[CR][LF] finished[CR][LF]
11	CMem[CR]	Deleting of all records in memory. Deletion usually takes a few seconds. The end is marked by "finished".	CMem...finished[CR][LF]

Table 21: RS232 Read commands

[CR] = Carriage Return

[LF] = Line Feed

%d / %c / %f = Place holder

15.3 Configuration commands

#	Instruction format		Specification	Return format
1	Measuring time in seconds			
	Write	WMtime%d [CR]	%d = 30...300 Default: 60	Mtime:%d[s];CRC:z[CR][LF]
	Read	RMtime[CR]	-	
2	Pause time in seconds			
	Write	WHtime%d[CR]	%d = 1...86400 Default: 10	Htime:%d[s];CRC:z[CR][LF]
	Read	RHtime[CR]	-	
3	Operating mode			
	Write	SStartMode%d[CR]	%d = 0: time-controlled measurement (default) %d = 1: Digital I/O %d = 2: Key / RS232 %d = 3: Automatic	StartMode:%d;CRC:z[CR][LF]
	Read	RStartMode[CR]	-	
4	Autoparts: Number of particles if operating mode= Automatic			
	Write	WAutoParts%d[CR]	%d = 200...5000000 Default: 200	AutoParts:%d[-];CRC:z[CR][LF]
	Read	RAutoParts[CR]	-	
5	Start and stop of a measurement in operating mode "Key"			
	Start	Start[CR]	-	Measuring[CR][LF]
	Stop	Stop[CR]	-	See return format read command "RVal"
6	Volume flow in ml/min			
	Write	WFlow%d[CR]	%d = 0...400 0 = Automatic (default) 1...400 = Fixed value	Flow:%d[ml/min];CRC:z[CR][LF]
	Read	RFlow[CR]	-	
7	Automatic measurement value output via RS232			
	Write	SAutoT%d[CR]	%d = 0: deactivated (default) %d = 1: activated	AutoT:%d;CRC:z[CR][LF]
	Read	-	-	
8	Standard to be displayed			
	Write	SStd%d[CR]	%d = 0: ISO 4406:17 (default) %d = 1: SAE AS4059E %d = 2: NAS 1638 %d = 3: GOST 17216	Std:%d;CRC:z[CR][LF]
	Read	RCon[CR]	-	
9	Alarm type			
	Write	SAlarmD%d[CR]	%d = 0: Standard alarm %d = 1: Filter mode Default: 0	AlarmD:%d;CRC:z[CR][LF]
	Read	RCon[CR]	-	
10	Limit value alarm ISO/SAE 4µm (depending on set standard)			
	Write	WAlarm4%c[CR]	ISO: %c = 0...28 0 = Alarm deactivated Default: 0 SAE: %c = 000...12 000 = Alarm deactivated Default: 000	Alarm4:%c[-];CRC:z[CR][LF]
	Read	RAAlarm4[CR]	-	

#	Instruction format		Specification	Return format
11	Limit value alarm ISO/SAE 6µm (depending on set standard)			
	Write	WAlarm6%c[CR]	ISO: %c = 0...28 0 = Alarm deactivated Default: 0 SAE: %c = 000...12 000 = Alarm deactivated Default: 000	Alarm6:%c[-];CRC:z[CR][LF]
	Read	RAlarm6[CR]	-	
12	Limit value alarm ISO/SAE 14µm (depending on set standard)			
	Write	WAlarm14%c[CR]	ISO: %c = 0...28 0 = Alarm deactivated Default: 0 SAE: %c = 000...12 000 = Alarm deactivated Default: 000	Alarm14:%c[-];CRC:z[CR][LF]
	Read	RAlarm14[CR]	-	
13	Limit value alarm ISO/SAE 21µm (depending on set standard)			
	Write	WAlarm21%c[CR]	ISO: %c = 0...28 0 = Alarm deactivated Default: 0 SAE: %c = 000...12 000 = Alarm deactivated Default: 000	Alarm21:%c[-];CRC:z[CR][LF]
	Read	RAlarm21[CR]	-	
14	Limit value alarm NAS			
	Write	WAlarmNAS%c[CR]	%c = 00...12 00 = Alarm deactivated Default: 00	AlarmNAS:%c[-];CRC:z[CR][LF]
	Read	RAlarmNAS[CR]	-	
15	Limit value alarm GOST			
	Write	WAlarmGOST%c[CR]	%c = 00...17 00 = Alarm deactivated Default: 00	AlarmGOST:%c[-];CRC:z[CR][LF]
	Read	RAlarmGOST[CR]	-	
16	Limit value alarm temperature in °C			
	Write	WAlarmT%d[CR]	%c = 0..85 0 = Alarm deactivated Default: 0	AlarmT:%d[°C];CRC:z[CR][LF]
	Read	RAlarmT[CR]	-	
17	Current output			
	Write	SAO1%d[CR]]	%d = 0: deactivated %d = 1: ISO/SAE 4µm %d = 2: ISO/SAE 6µm %d = 3: ISO/SAE 14µm %d = 4: ISO/SAE 21µm %d = 5: ISO/SAE sequential (default) %d = 6: NAS %d = 7: GOST	AO1:%d;CRC:z[CR][LF]
	Read	RCon[CR]	-	

#	Instruction format		Specification	Return format
18	Low-pass filter			
	Write	WMean%d[CR]	%d = 1...255 1 = no filter Default: 2	Mean:%d[-];CRC:z[CR][LF]
	Read	RMean[CR]	-	
19	Communication type			
	Write	SComMode%d[CR]	%d = 0: RS232 (default) %d = 1: CANopen %d = 2: Autodetect %d = 3: CAN J1939	ComMode:%d;CRC:z[CR][LF]
	Read	-	-	Siehe Antwort: "RCon"
20	RS232 Transmission rate			
	Write	SRSBR%d[CR]	%d = 0: 9600 Baud (default) %d = 1: 19200 Baud %d = 2: 57600 Baud %d = 3: 115200 Baud	RSBR:%d;CRC:z[CR][LF]
	Read	-	-	
21	CAN Scheduling			
	Write	SCTRM%d[CR]	%d = 0: deactivated (default) %d = 1: aktiviert (120Ω)	CTRM:%d;CRC:z[CR][LF]
	Read	-	-	
22	CAN Transmission rate			
	Write	SCOBR%d[CR]	%d = 3: 125K Baud %d = 4: 250K Baud (default) %d = 5: 500K Baud %d = 6: 1000K Baud	COBR:%d;CRC:z[CR][LF]
	Read	-	-	
23	CAN Node-ID			
	Write	WCROID%d[CR]	%d = 1...255 Default: 10	COID:%d[-];CRC:z[CR][LF]
	Read	RCOID[CR]	-	
24	CAN Auto Default			
	Write	WCAutoDef%d[CR]	Decision which protocol should be spoken (CANopen oder CAN J1939) if communication type = Autodetect %d = 0: CANopen (default) %d = 1: CAN J1939	CAutoDef:%d[-];CRC:z[CR][LF]
	Read	RCAutoDef[CR]	-	
25	CAN J 1939 - Interval in seconds for PDU 2			
	Write	WCJInt%d[CR]	%d = 0...60 0 = to be sent on value change Default: 10	CJInt:%d[s];CRC:z[CR][LF]
	Read	RCJInt[CR]	-	

Table 22: RS232 Configuration commands

[CR] = Carriage Return

[LF] = Line Feed

%d / %c / %f = Place holder

15.4 Checksum calculation (CRC)

To check if the response to the command was transmitted error-free, the checksum (CRC) can be used.

The decimal value of each character sent in a string (see ASCII-table) has to be added up. Including Line feed [LF] and Carriage Return [CR]. If the result is dividable through 256, the transmission is error-free.

An example of the response of the OPCom to the command „RMemS[CR]“ is shown below. (Reading out the memory usage)

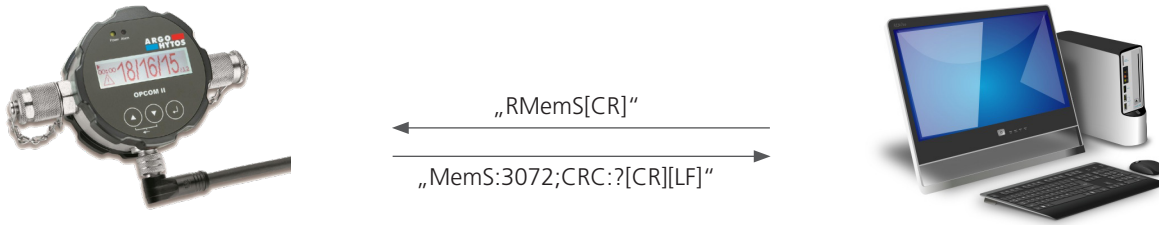

Fig. 24: Example data transmission RS232 with checksum

Response	Significance (decimal) according to ASCII-Table
M	77
e	101
m	109
S	83
:	58
3	51
0	48
7	55
2	50
[91
-	45
]	93
;	59
C	67
R	82
C	67
:	58
?	63
[CR]	13
[LF]	10
Sum	1280 → 1280 / 256 = 5 Rest 0 → Error-free transmission

Table 23: Example checksum calculation (CRC)

16. Communication CAN

The CAN interface meets the „CAN 2.0B Active Specification“.

The sensor supports a limited number of transmission speeds on the CAN-bus.

Data rate	Supported	CiA Draft 301	Bus length acc. to CiA Draft Standard 301
1 Mbit/s	yes	yes	25 m
800 kbit/s	no	yes	50 m
500 kbit/s	yes	yes	100 m
250 kbit/s	yes	yes	250 m
125 kbit/s	yes	yes	500 m
100 kbit/s	no	no	750 m
50 kbit/s	no	yes	1000 m
20 kbit/s	no	yes	2500 m
10 kbit/s	no	yes	5000 m

Table 24: Supported bus speeds at CANopen and associated cable lengths

16.1 CANopen

The CANopen protocol defines what is described, not the way something is described. With the implemented methods, a distributed control network is realized which can connect everything, from very simple participants to very complex controllers without causing communication problems between the participants.

Parameter	Size	Unit
Typical response time to SDO queries	<10	ms
Maximum response time to SDO queries	150	ms
Supply voltage CAN transceiver	3,3	V
Integrated scheduling	no	-

Table 25: Electrical parameter CANopen interface

The central concept of CANopen is the so-called Device Object Dictionary (OD), a concept which is also used in other fieldbus systems.

The chapters below will first address the Object Dictionary, then the Communication Profile Area (CPA), and finally the CANopen communication procedure.

The following figure is for illustrative purposes only, the implementation meets the CAN 2.0B specification.

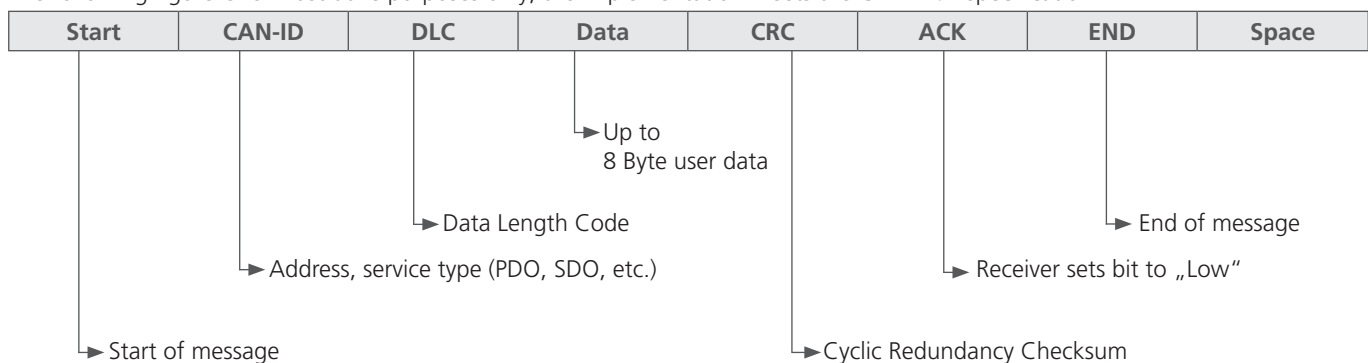

Fig. 25: CANopen message format

16.1.1 „CANopen Object Dictionary“ in general

The CANopen Object Dictionary (OD) is an object directory in which each object can be addressed with a 16 bit index. Each object can consist of several data elements that can be addressed by means of an 8-bit sub index.

The basic layout of a CANopen object dictionary is shown in the following table.

Index (hex)	Object
0000	-
0001 - 001F	Static data types (Boolean, integer)
0020 - 003F	Complex data types (consisting of standard data types)
0040 - 005F	Complex data types, manufacturer-specific
0060 - 007F	Static data types (device profile-specific)
0080 - 009F	Complex data types (device profile-specific)
00A0 - 0FFF	Reserved
1000 - 1FFF	Communication Profile Area (e.g. device type, error register, supported PDOs etc.)
2000 - 5FFF	Communication Profile Area (manufacturer-specific)
6000 - 9FFF	Device profile-specific Device Profile Area (e.g. "DSP-401 Device Profile for I/O Modules")
A000 - FFFF	Reserved

Table 26: General CANopen Object Dictionary structure

16.1.2 CANopen Communication Objects

Communication objects transferred with CANopen are described by services and protocols and are classified as follows:

- › Network Management (NMT) provides services and is used for bus initialization, error handling and node control
- › Process Data Objects (PDOs) are used to transfer process data in real-time
- › Service Data Objects (SDOs) enable read and write access to the object dictionary of a node
- › Special Function Object protocol allows application-specific network synchronization, timestamp transfer and emergency messages

An example of network initialization using a CANopen Master and a sensor is described below.

- (A) After connection to the current supply, the sensor sends a Boot Up message within approx. five seconds once the pre-operational status has been reached. In this state, the sensor only sends heartbeat messages if configured accordingly (see point A Fig. 26).
- (B) Then the sensor can be configured via SDOs; in most cases this is not necessary, since the once set communication parameters are automatically saved by the sensor (see point B Fig. 26).
- (C) In order to set the sensor into the operational state, you can either send an appropriate message to all CANopen participants or specifically to the sensor. In operational state, the sensor sends the supported PDOs according to its configuration either at periodic intervals or as triggered synch messages (see Paragraph C in Fig. 26).

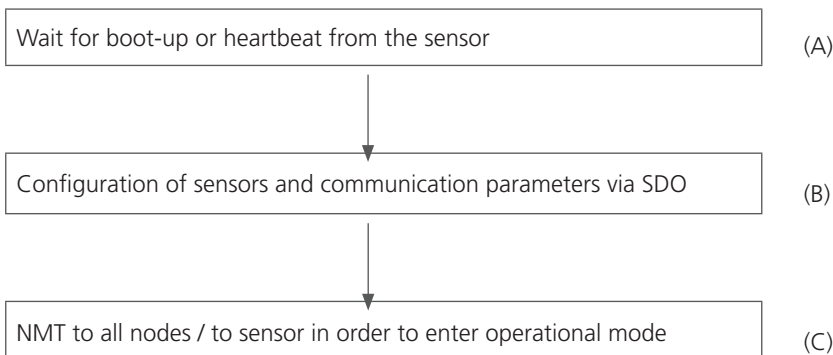

Fig. 26: CANopen Bus initialization process

Depending on the sensor state, various services of the CANopen protocol are available:

Com. Object	Initializing	Pre-Operational	Operational	Stopped
PDO			X	
SDO		X	X	
Synch		X	X	
BootUp	X			
NMT		X	X	X

Table 27: Available CANOpen services in various sensor states

16.1.3 Service Data Object (SDO)

Service Data Objects provide read and write access to the sensor's object dictionary. The SDOs are acknowledged; transfer is always performed between only two participants, a so-called client / server model.

The sensor can only function as a server, it only responds to SDO messages and does not spontaneously send any queries to other participants. The ID of the SDO messages from the sensor to the client is NodeID+0x580. The expected ID for requests from the client to the sensor (server) in the case of SDO messages is NodeID+0x600.

The standard protocol for SDO transfer requires 4 bytes in order to encode the sender direction, data type, index and sub-index. Thus 4 bytes remain of the 8 bytes of a CAN data field for the data content. For objects whose data content is greater than 4 bytes, there are two additional protocols for the so-called fragmented or segmented SDO transfer.

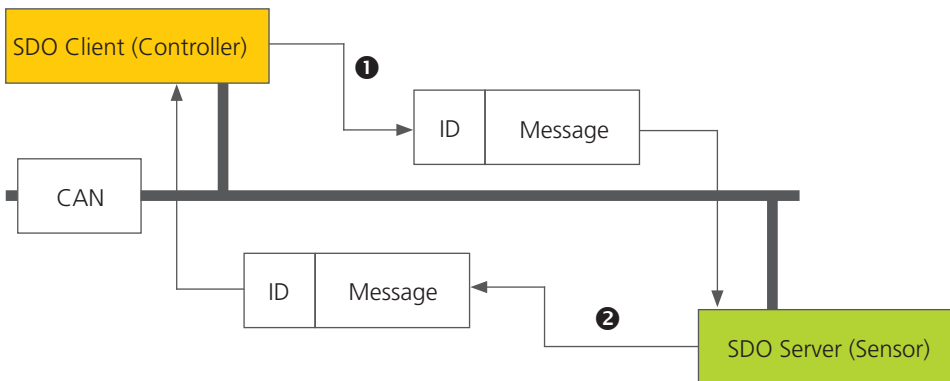

Fig. 27: SDO Client / Server relationship

SDOs are intended to configure the sensor via access to the object dictionary, to inquire seldom needed data or configuration values, or to download large data volumes. The SDO features at a glance:

- › Access to all data in the object dictionary
- › Confirmed transfer
- › Client / Server relationship when communicating

The control and user data of a non-segmented SDO standard message is distributed across the CAN message as shown in the following table. The user data in an SDO message usually consists of up to 4 bytes. The control data in an SDO message (Cmd, index, sub-index) is used to determine the direction of access to the object dictionary and the transferred data type if applicable. Please consult "CiA Draft Standard 301" for the exact specifications of the SDO protocol.

CAN	CAN-ID	DLC	CAN Message user data						
			0	1	2	3	4	5	6
CANopen SDO	COB-ID 11 Bit	DLC	Cmd	Index	Sub-index	CANopen SDO Message user data			

Table 28: Setup of a SDO message

An example of an SDO query of the sensor serial number from the object dictionary as sent to Index 0x1018, Sub-index 4, with a 32 bit data length is shown below. The client (controller) sends a read request to the sensor with the ID "NodeID" (see Table 29).

CAN	CAN-ID	DLC	CAN Message user data							
			0	1	2	3	4	5	6	7
CANopen	COB-ID 11 Bit	DLC	Cmd	Index		Subidx	SDO user data			
				1	0	0	3	2	1	0
Message from client to sensor	0x600 + NodeID	0x08	0x40	0x18	0x10	0x04	dont care	dont care	dont care	dont care

Table 29: SDO download request from the client to the server

The sensor responds with a corresponding SDO message (see Table 30) encoding the data type, index, sub-index and serial number of the sensor, in this example serial number 200123 (0x30DBB).

CAN	CAN-ID	DLC	CAN Message user data							
			0	1	2	3	4	5	6	7
CANopen	COB-ID 11 Bit	DLC	Cmd	Index		Subidx	SDO user data			
				1	0	0	3	2	1	0
Message from client to sensor	0x580 + NodeID	0x08	0x43	0x18	0x10	0x04	0xBB	0x0D	0x30	0x00

Table 30: SDO download response from the server to the client

An example of the data upload (heartbeat time) via SDO to the sensor object dictionary at index 0x1017 with a data length of 16 bits is shown below. To do this, the client (control) sends a write request to the sensor using the ID "NodeID" (see Table 31) in order to set the heartbeat time to 1000 ms (0x03E8).

CAN	CAN-ID	DLC	CAN Message user data							
			0	1	2	3	4	5	6	7
CANopen	COB-ID 11 Bit	DLC	Cmd	Index		Subidx	SDO user data			
				1	0	0	3	2	1	0
Message from client to sensor	0x600 + NodeID	0x08	0x2B	0x17	0x10	0x00	0xE8	0x03	0	0

Table 31: SDO upload request from the client to the server

The sensor responds with a corresponding SDO message (see Table 32) confirming that the access attempt was successful and that the index and sub-index on which access occurred have been encoded.

CAN	CAN-ID	DLC	CAN Message user data							
			0	1	2	3	4	5	6	7
CANopen	COB-ID 11 Bit	DLC	Cmd	Index		Subidx	SDO user data			
				1	0	0	3	2	1	0
Message from client to sensor	0x580 + NodeID	0x08	0x60	0x17	0x10	0x00	0x00	0x00	0x00	0x00

Table 32: SDO upload response from the server to the client

16.1.4 Process Data Object (PDO)

PDOs are one or more data sets mirroring up to 8 bytes of data in a CAN message from the object dictionary for the purpose of transferring data quickly from a "producer" to one or more "consumers" (see Fig. 28).

Each PDO has a unique COB-ID (Communication Object Identifier), and is only sent from one single node; but may be received by several nodes, and need not be acknowledged / confirmed.

PDOs are ideally suited to transfer data from sensors to the controller, or from the control system to actuators. PDO attributes of the sensor at a glance:

- › Sensor supports three transmit PDOs (TPDOs), but no RPDOs. The level sensors support four TPDOs.
- › Data mapping in PDOs is fixed and cannot be changed

The sensor supports two different PDO transfer methods.

1. When using the event or timer-triggered method, transfer is triggered by an internal timer or event in the sensor.
2. In the SYNCH-triggered method, transfer is performed in response to a SYNCH message (CAN message from a SYNCH producer without user data). The response using PDO is either sent on each received Synch, or after every 'n' SYNCH message received.

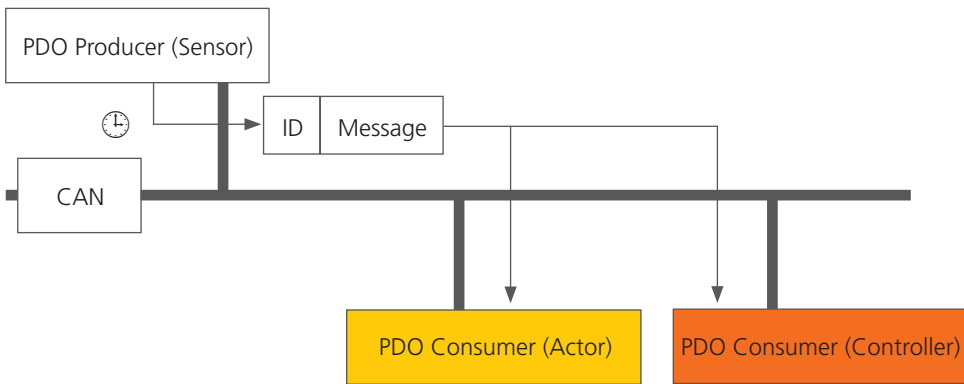

Fig. 28: PDO Consumer/producer relationship

16.1.5 PDO Mapping

The sensor supports three to four transmit PDOs (TPDOs) to allow the most effective operation of the CAN-bus. The sensor does not support dynamic mapping of PDOs, the mapping parameters are therefore only readable but not writeable.

Fig. 30 shows the principle of the mapping of objects from the OD in a TPDO, it corresponds to CiA DS-301, Chapter 9.5.4. Which objects are mapped in TPDO 1 to 4 can be determined in the OD at index 0x1A00 to 0x1A03. The structure of the PDO mapping entries is displayed in Fig. 29. Furthermore, each TPDO has a description of the communication parameters, such as transmission type, COB-ID and possibly the event timer. The communication parameters for the TPDOs 1 to 4 are documented in OD at the index 0x1800 to 0x1803.

		LSB
Index (16 Bit)	Sub-index (8 Bit)	Object length in Bit (8 Bit)

Fig. 29: Basic structure of a PDO mapping entry

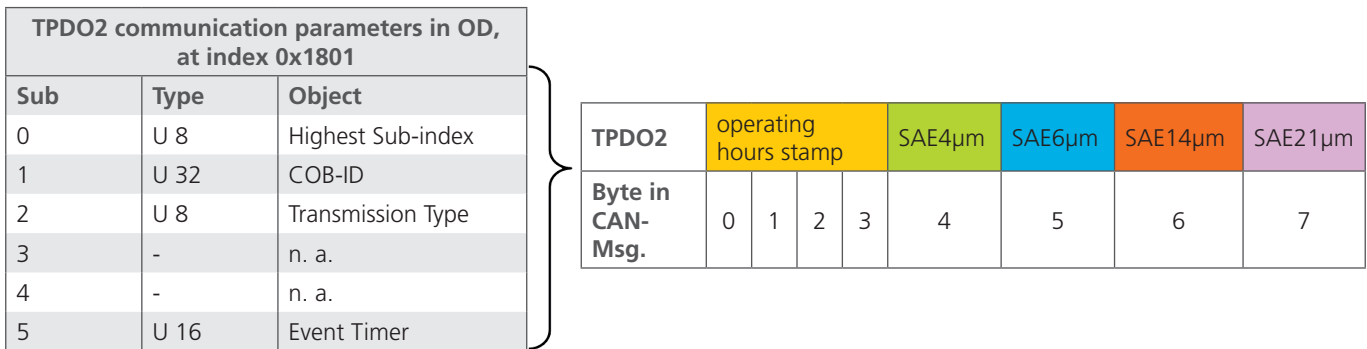
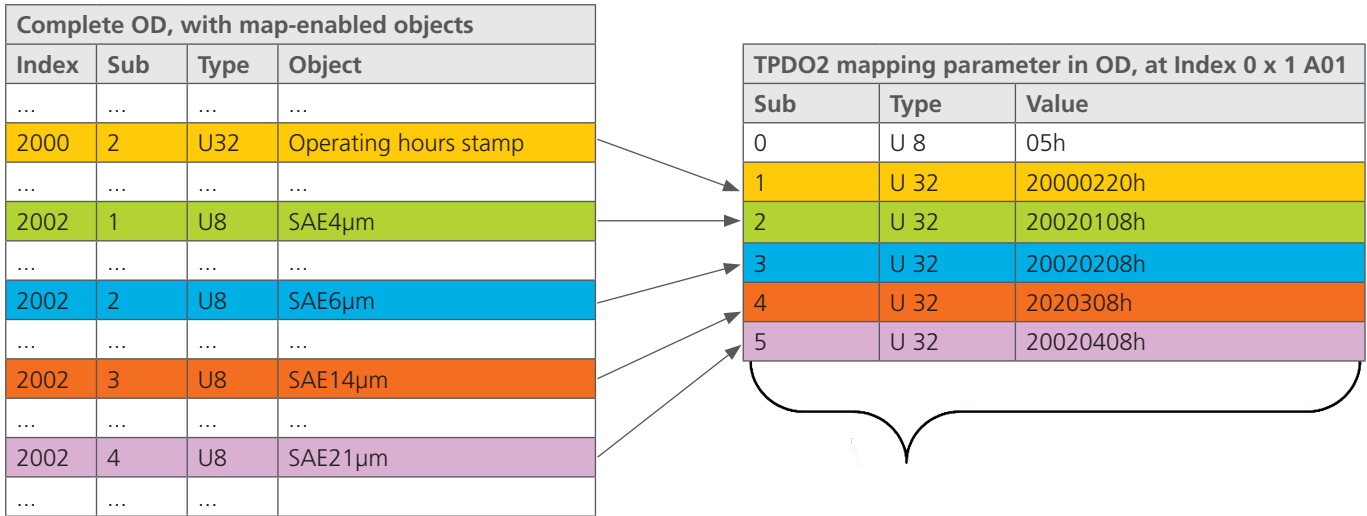

Fig. 30: Principle of mapping of several OD-objects in one TPDO

The sensor supports certain types of TPDO (see table 33), which can be inserted for the respective communication parameters of the TPDOs (see Fig. 30).

Type	supported	cyclically	not cyclically	synchronously	asynchronously
0	yes		x	x	
1-240	yes	x		x	
241-253	no				
254	yes				x
255	yes				x

Table 33: Description of TPDO types

16.1.6 „CANopen Object Dictionary“ in detail

The complete object dictionary is represented in the following table. With few exceptions, the possible settings correspond to the CANopen Standard as described in DS 301.

Suitable EDS files for the sensors are available on the homepage of ARGO-HYTOS GMBH.

Idx	SIdx	name	type	Attr.	mapped on PDO	default	notes
1000h	0	device type	unsigned 32	ro		194h	sensor, see DS 404
1001h	0	error register	unsigned 8	ro		00h	mandatory see DS301
1017h	0	producer heartbeat time	unsigned 16	rw		1338h	heartbeat time in ms, range: 0..65535
1018h		identity object	record	ro			
	0	number of entries	unsigned 8	ro		04h	largest sub index
	1	vendor ID	unsigned 32	ro		000000E6h	ARGO-HYTOS
	2	product code	unsigned 32	ro		00004F4CH	OPCom II
	3	revision number	unsigned 32	ro		1000	device dependent
	4	serial number	unsigned 32	ro			device dependent
1800h		transmit PDO1 parameter	record				
	0	number of entries	unsigned 8	ro		05h	largest sub index
	1	COB-ID	unsigned 32	rw		180h+ NodeID	COB-ID used by PDO, range: 181h..1FFh, can be changed while not operational
	2	transmission type	unsigned 8	rw		FFh	cyclic + synchronous, asynchronous values: 1-240, 254, 255
	5	event time	unsigned 16	rw		1F4h	event timer in ms for asynchronous TPDO1, value has to be a multiple of 50 and max 12700
1801h		transmit PDO2 parameter	record				
	0	number of entries	unsigned 8	ro		05h	largest sub index
	1	COB-ID	unsigned 32	rw		280h+ NodeID	COB-ID used by PDO, range: 281h..2FFh, can be changed while not operational
	2	transmission type	unsigned 8	re		FFh	cyclic + synchronous, asynchronous values: 1-240, 254, 255
	5	event time	unsigned 16	rw		1F4h	event timer in ms for asynchronous TPDO2 range: 0..65000
1802h		transmit PDO3 parameter	record				
	0	Number of entries	unsigned 8	ro		05h	largest sub index
	1	COB-ID	unsigned 32	rw		380h+ NodeID	COB-ID used by PDO, range: 381h..3FFh, can be changed while not operational
	2	transmission type	unsigned 8	rw		FFh	cyclic + synchronous, asynchronous values: 1-240, 254, 255

Idx	SIdx	name	type	Attr.	mapped on PDO	default	notes
	5	event timer	unsigned 16	rw		1F4h	event timer in ms for asynchronous TPDO3 range: 0..65000
1803h		transmit PDO4 parameter	record				
	0	number of entries	unsigned 8	ro		05h	largest sub index
	1	COB-ID	unsigned 32	rw		480h+ NodeID	COB-ID used by PDO, range: 481h..4FFh, can be changed while not operational
	2	transmission type	unsigned 8	rw		FFh	cyclic + synchronous, asynchronous values: 1-240, 254, 255
	5	event time	unsigned 16	rw		1F4h	event timer in ms for asynchronous TPDO3 range: 0..65000
1A00h		TPDO1 mapping parameter	record				
	0	Number of entries	unsigned 8	ro		05h	largest sub index
	1	PDO mapping for 1st app obj. to be mapped	unsigned 32	co		20000220h	20000220h
	2	PDO mapping for 2nd app obj. to be mapped	unsigned 32	co		20010108h	ISO4µm, 1 Byte im 2001h, sub 01
	3	PDO mapping for 3rd app obj. to be mapped	unsigned 32	co		20010208h	ISO6µm, 1 Byte im 2001h, sub 02
	4	PDO mapping for 4th app obj. to be mapped	unsigned 32	co		20010308h	ISO14µm, 1 Byte im 2001h, sub 03
	5	PDO mapping for 5th app obj. to be mapped	unsigned 32	co		20010408h	ISO21µm, 1 Byte im 2001h, sub 04
1A01h		TPDO2 mapping parameter	record				
	0	Number of entries	unsigned 8	ro		05h	largest sub index
	1	PDO mapping for 1st app obj. to be mapped	unsigned 32	co		20000220h	timestamp of the measurement, 4 Byte
	2	PDO mapping for 2nd app obj. to be mapped	unsigned 32	co		20020108h	SAE4µm, 1 Byte im 2002h, sub 01
	3	PDO mapping for 3rd app obj. to be mapped	unsigned 32	co		20020208h	SAE6µm, 1 Byte im 2002h, sub 02
	4	PDO mapping for 4th app obj. to be mapped	unsigned 32	co		20020308h	SAE14µm, 1 Byte im 2002h, sub 03
	5	PDO mapping for 5th app obj. to be mapped	unsigned 32	co		20020408h	SAE21µm, 1 Byte im 2002h, sub 04
1A02h		TPDO3 mapping parameter	record				
	0	number of entries	unsigned 8	ro		05h	largest sub index

Idx	SIdx	name	type	Attr.	mapped on PDO	default	notes
	1	PDO mapping for 1st app obj. to be mapped	unsigned 32	co		20000120h	operating hours, 4 Byte
	2	PDO mapping for 2nd app obj. to be mapped	unsigned 32	co		20030108h	oil condition bits, 1 Byte
	3	PDO mapping for 3rd app obj. to be mapped	unsigned 32	co		20030708h	measurement bits, 1 Byte
	4	PDO mapping for 4th app obj. to be mapped	unsigned 32	co		20030808h	sensor status bits, 1 Byte
	5	PDO mapping for 5th app obj. to be mapped	unsigned 32	co		20040008h	temperature, 1 Byte
1A03h		TPDO4 mapping parameter	record				
	0	Number of entries	unsigned 8	ro		03h	largest sub index
	1	PDO mapping for 1st app obj. to be mapped	unsigned 32	co		20000220h	timestamp of the measurement, 4 Byte
	2	PDO mapping for 2nd app obj. to be mapped	unsigned 32	co		20060108h	NAS, 1 Byte in 2006h, sub 01
	3	PDO mapping for 3rd app obj. to be mapped	unsigned 32	co		20070108h	GOST, 1 Byte in 2007h, sub 01
2000h		time related parameters of the sensor	record				
	0	number of entries	unsigned 8	ro		04h	largest sub index
	1	operating hours	unsigned 32	ro	y		sensor up time in seconds
	2	timestamp of the last measurement	unsigned 32	ro	y		timestamp of the last measurement
	3	laser operation hours in hours	unsigned 32	ro			laser operation hours
	4	time to calibration note S1 in hours	unsigned 32	ro			time to calibration note S1
2001h		ISO measurement	record				
	0	number of entries	unsigned 8	ro		04h	largest sub index
	1	ISO4µm	unsigned 8	ro	y		
	2	ISO6µm	unsigned 8	ro	y		
	3	ISO14µm	unsigned 8	ro	y		
	4	ISO21µm	unsigned 8	ro	y		
2002h		SAE measurement	record				
	0	number of entries	unsigned 8	ro		04h	largest sub index
	1	SAE4µm	unsigned 8	ro	y		offset of two to display 000, 00 and 0, valid for all classes 0 == SAE 000 1 == SAE 00 2 == SAE 0 3 == SAE 1 ... 14 == SAE 12 (maximum value)

Idx	SIdx	name	type	Attr.	mapped on PDO	default	notes
	2	SAE6µm	unsigned 8	ro	y		
	3	SAE14µm	unsigned 8	ro	y		
	4	SAE 21µm	unsigned 8	ro	y		
2003h		condition monitoring bits	array				
	0	number of entries	unsigned 8	ro		08h	largest sub index
	1	oil specific bits	unsigned 8	ro	y		0 concentration limit exceeded 1 flow high 2 flow low 3 measurement not plausible (air...)
	2	reserved	unsigned 8	ro			
	3	reserved	unsigned 8	ro			Bit 0: calibration limit S1 reached Bit 1: calibration limit S5 reached
	4	reserved	unsigned 8	ro			
	5	reserved	unsigned 8	ro			
	6	reserved	unsigned 8	ro			
	7	measurement info	unsigned 8	ro	y		Bit0: measurement is running Bit1: operating mode: time Bit2: operating mode: Digital I/O Bit3: operating mode: Button Bit4: alarm type: (1)filter/(0)standard Bit5: power-up Bit6: concentration alarm Bit7: temperature alarm
	8	sensor alarm	unsigned 8	ro	y		Bit0: laser current high Bit1: laser current low Bit2: voltage high Bit3: voltage low Bit4: temperature high Bit5: temperature low Bit6: - Bit7: operating mode: auto
2004h	0	sensor temperature	signed 8	ro	y		temperature in °C
2005h	0	flow index	unsigned 16	ro			Flow index (0..500)
2006h		NAS measurement	record				
	0	number of entries	unsigned 8	ro		01h	largest sub index
	1	NAS	unsigned 8	ro	y		offset of one to display 00 and 0 0 == NAS 00 1 == NAS 0 2 == NAS 1 ... 13 == NAS 12 (maximum value)
2007h		GOST measurement	record				
	0	number of entries	unsigned 8	ro		01h	largest sub index

Idx	SIdx	name	type	Attr.	mapped on PDO	default	notes
	1	GOST 17216	unsigned 8	ro	y		offset of one to display 00 and 0 0 == GOST 00 1 == GOST 0 2 == GOST 1 17 == GOST 16 (maximum value)
2020h		commando	unsigned 8	wo			1 = start of a measurement 2 = stop of a measurement 3 = result between
2030h		measurement related settings	record				
	0	number of entries	unsigned 8	ro		4h	largest sub index
	1	measurement time	unsigned 32	rw			Measurement Time in s
	2	hold time	unsigned 32	rw			Time between Measurements
	3	operation mode	unsigned 16	rw			0 = time Control 1 = digital I/O 2 = button 3 = automatic
	4	history disable	unsigned 16	rw		0h	0 = history enabled 1 = history disabled
2031h		startup settings	record				
	0	number or entries	unsigned 8	ro		4h	largest sub index
	1	start mode	unsigned 16	rw		0h	0 = Network with NMT Master (Init => PreOp => Start_Remote_Node => Operational) >0 = Network without NMT Master (Init => Operational)
	2	communication type	unsigned 16	rw			enabled communication interface: 0: RS232 1: CANopen 2: auto 3: J1939
	3	baud rate CAN	unsigned 16	rw			baud rate CAN: 3: 125k 4: 250k 5: 500k 6: 1000k
	4	baud rate RS232	unsigned 16	rw			baud rate RS232: 0: 9600 1: 19200 2: 57600 3: 115200
2032h		standard & alarm related settings	record				
	0	number of entries	unsigned 8	ro		9h	largest sub index
	1	display & alarm standard	unsigned 16	rw			displayed Standard and alarm trigger bit setting 0 = ISO 1 = SAE 2 = NAS 3 = GOST
	2	alarm type	unsigned 16	rw			0 = standard alarm 1 = filter mode

Idx	SIdx	name	type	Attr.	mapped on PDO	default	notes
	3	alarm value temperature	unsigned 8	rw			range: 0..85 °C 0 = disabled
	4	alarm value ISO/SAE4µm	unsigned 8	rw			alarm threshold 4µm (note the offset)
	5	alarm value ISO/SAE6µm	unsigned 8	rw			alarm threshold 4µm (note the offset)
	6	alarm value ISO/SAE14µm	unsigned 8	rw			alarm threshold 4µm (note the offset)
	7	alarm value ISO/SAE21µm	unsigned 8	rw			alarm threshold 4µm (note the offset)
	8	alarm value NAS	unsigned 8	rw			alarm threshold NAS (note the offset)
	9	alarm value GOST	unsigned 8	rw			alarm threshold GOST (note the offset)
2100h		readmem control functions	record				
	0	number of entries	unsigned 8	ro		4h	largest sub index
	1	size of history memory	unsigned 32	ro		device dependent	size of memory in datasets
	2	used history mem	unsigned 32	ro			used datasets within memory (corresponds internally to write pointer)
	3	reading pointer, dataset	unsigned 32	rw			autoincrementing read pointer to a dataset for history memory reading; can be between 0 and current write pointer
	4	clear history memory	unsigned 16	wo			1 = clear memory
2101h	0	readmem Initiate segmented SDO data upload	unsigned 32	ro			Appropriate Pointer has to be set (with 2100sub3) before start reading, Size of the record will be sent back on reading

Table 34: Communication-related object dictionary

16.2 CAN J1939

For further information see www.argo-hytos.com



Function available only from software version 2.00.15.

17. Classification systems

The automatic particle counter (APC), which is used for the calibration of the OPCom particle monitor is primary calibrated according to ISO 11171.

The ordinal numbers of the OPCom particle monitor are displayed according to ISO 4406. these are determined by the measured particle concentration for 4. 6. 14 and 21 $\mu\text{m(c)}$.

For the successor of NAS. SAE AS and for the GOST standard. other size classes are used. The sizes can be converted with a small loss of accuracy.

17.1 Definition of particle sizes

In industrial hydraulics. the particle numbers are coded according to ISO 4406:17. With the replacement of the test dust ACFTD by ISO MTD. the particle sizes have been redefined.



Fig. 31: Particle size definition

ISO-MTD	> 4 $\mu\text{m(c)}$	> 6 $\mu\text{m(c)}$	> 14 $\mu\text{m(c)}$	> 21 $\mu\text{m(c)}$	> 38 $\mu\text{m(c)}$	> 70 $\mu\text{m(c)}$
ACFTD	> 2 μm	> 5 μm	> 15 μm	> 25 μm	> 50 μm	> 100 μm

Table 35: Comparison of particle size ISO-MTD - ACFTD

The size specification in $\mu\text{m(c)}$ is the diameter of a circle having the same area as the projected area of the detected particle.

The size specifications of ISO-MTD and ACFTD can be converted into each other. See table below.

17.1.1 Cleanliness classes according to ISO 4406:17

The values are added in cumulated form (all particles >4 μm . all particles > 6 μm).

Concentration in particles / ml		ISO 4406:17	Display OPCom
From	up to and including		
2,500,000.00		> 28	28
1,300,000.00	2,500,000.00	28	28
640,000.00	1,300,000.00	27	27
320,000.00	640,000.00	26	26
160,000.00	320,000.00	25	25
80,000.00	160,000.00	24	24
40,000.00	80,000.00	23	23
20,000.00	40,000.00	22	22
10,000.00	20,000.00	21	21
5,000.00	10,000.00	20	20
2,500.00	5,000.00	19	19
1,300.00	2,500.00	18	18
640.00	1,300.00	17	17
320.00	640.00	169	16
160.00	320.00	15	15
80.00	160.00	14	14
40.00	80.00	13	13
20.00	40.00	12	12

Table 35: Comparison of particle size ISO-MTD-ACFTD

Concentration in particles / ml		ISO 4406:17	Display OPCOM
From	up to and including		
10.00	20.00	11	11
5.00	10.00	10	10
2.50	5.00	9	9
1.30	2.50	8	8
0.64	1.30	7	7
0.32	0.64	6	≤ 6
0.16	0.32	5	≤ 6
0.08	0.16	4	≤ 6
0.04	0.08	3	≤ 6
0.02	0.04	2	≤ 6
0.01	0.02	1	≤ 6
0.00	0.01	0	0

Table 36: Determination of cleanliness classes according to ISO 4406:17

17.1.2 Cleanliness classes according to SAE AS 4059E

The values are added in cumulated form (all particles >4 µm, all particles > 6 µm, ...), comparable to ISO.

All data in µm (c)

Concentration in particles / ml (ISO MTD)				SAE AS 4059E	Display OPCOM
> 4 µm (A)	> 6 µm (B)	> 14 µm (C)	> 21 µm (D)		
1.95	0.76	0.14	0.03	000	000
3.90	1.52	0.27	0.05	00	00
7.80	3.04	0.54	0.10	0	0
15.60	6.09	1.09	0.20	1	1
31.20	12.20	2.17	0.39	2	2
65.20	24.30	4.32	0.76	3	3
125.00	48.60	8.64	1.52	4	4
250.00	97.30	17.30	3.06	5	5
500.00	195.00	34.60	6.12	6	6
1,000.00	389.00	69.20	12.20	7	7
2,000.00	779.00	139.00	24.50	8	8
4,000.00	1,560.00	277.00	49.00	9	9
8,000.00	3,110.00	554.00	98.00	10	10
16,000.00	6,230.00	1,110.00	196.00	11	11
32,000.00	12,500.00	2,220.00	392.00	12	12

Table 37: Determination of cleanliness classes according to SAE AS 4059E

17.1.3 Cleanliness classes according to NAS 1638



Function only available from software version 2.00.15.

The NAS 1638 is divided into different size classes. 5-15µm, 15-25µm, 25-50µm, ...
The particles are counted differentially and not accumulated as in ISO 4406.



The OPCOM can only measure the sizes 4, 6, 14, 21 µm. Therefore, the cleanliness class is calculated only based on NAS 1638.

A direct recalculation of NAS to ISO is not possible.

The concentrations are calculated according to the following scheme:

- › Concentration NAS(5-15µm) = Concentration ISO6µm – Concentration ISO14µm
- › Concentration NAS(15-25µm) = Concentration ISO14µm – Concentration ISO21µm
- › Concentration NAS(25-50µm) = Concentration ISO21µm

The according NAS ordinal number is determined with the following table. The largest of the three determined NAS ordinal numbers constitutes the result.

Concentration in particles / ml			NAS 1638 Display OPCOM
5-15µm	15-25µm	25-50µm	
1.25	0.22	0.01	00
2.50	0.44	0.08	0
5.00	0.89	0.16	1
10.00	1.78	0.32	2
20.00	3.56	0.63	3
40.00	7.12	1.26	4
80.00	14.25	2.53	5
160.00	28.50	5.06	6
320.00	57.00	10.12	7
640.00	114.00	20.25	8
1,280.00	228.00	40.50	9
2,560.00	456.00	81.00	10
5,120.00	910.00	162.00	11
10,240.00	1,824.00	324.00	12

Table 38: Determination of cleanliness classes according to NAS 1638

Even if there is no direct reference between ISO 4406 and NAS 1638, the following table may serve as an indication.

NAS	ISO	NAS	ISO
3	- / 12 / 9	8	- / 17 / 14
4	- / 13 / 10	9	- / 18 / 15
5	- / 14 / 11	10	- / 19 / 16
6	- / 15 / 12	11	- / 20 / 17
7	- / 16 / 13		

Table 39: Comparison of ISO 4406 and NAS 1638 (approximately)

17.1.4 Cleanliness classes according to GOST 17216



Function only available from software version 2.00.15.

The GOST 17216 is divided into different size classes. 5-15µm, 15-25µm, 25-50µm, ...
The particles are counted differentially and not accumulated as in ISO 4406



The OPCom can only measure the sizes 4, 6, 14, 21 µm. Therefore, the cleanliness class is calculated only based on GOST 17216.

The displayed GOST ordinal number is derived from the ISO 4406 ordinal numbers.

The following table shows the determination of the GOST ordinal number. If the determined ordinal number (ISO 4, 6 or 14µm) is higher than the corresponding value in the table, the next higher GOST ordinal number is used.

A direct recalculation of GOST to ISO is not possible.

ISO 4406:17			GOST 17216
4 µm	6 µm	14 µm	Display OPCom
6	5	3	00
7	5	3	0
8	6	4	1
9	7	5	2
-	8	6	3
-	9	7	4
-	10	8	5
-	11	9	6
-	12	9	7
-	13	10	8
-	14	12	9
-	15	13	10
-	16	13	11
-	17	14	12
-	18	16	13
-	19	16	14
-	20	18	15
-	21	19	16
-	22	20	17

Table 40: Determination of the cleanliness classes according to GOST 17216



CAUTION

Ingress of dirt and fluids causes disorders

Premature wear, malfunctions! Risk of damage! Property damage!
The safe function of the OPCom Particle Monitor is thus no longer guaranteed.

- ▶ Ensure absolute cleanliness when working at the hydraulic system.
- ▶ Do not use a high-pressure cleaner.

Damage to the surface by solvents and aggressive detergents!

Aggressive detergents may damage the seals of the OPCom Particle Monitor and let them age faster.

- ▶ Never use solvents or aggressive detergents.
- ▶ Do not use a high-pressure cleaner.

Damage to the hydraulic system and the seals

The water pressure of a high-pressure cleaner can damage the hydraulic system and the seals of the OPCom Particle Monitor. The water displaces the oil from the hydraulic systems and the seals.

- ▶ Do not use a high-pressure cleaner for cleaning.

Close all openings with suitable protective caps / devices.

Check that all seals and caps of the plug-in connections are secure, so that no humidity can penetrate into the OPCom Particle Monitor.

Clean the OPCom Particle Monitor only with a dry, lint free tissue.

18.1 Maintenance

When properly used, the OPCom Particle Monitor is maintenance-free.

NOTE

Note that the device needs to be calibrated once a year by the manufacturer.
If this calibration is not carried out, the warranty expires.

18.2 Repair

ARGO-HYTOS offers a comprehensive range of services for repair of the OPCom Particle Monitor.

Spare parts are not offered.

Repair to the OPCom Particle Monitor may only be carried out by the manufacturer or authorized distributors and subsidiaries. There is no guarantee for self-initiated repairs.

The OPCom particle monitor is a component which does not have to be taken out of operation. Therefore, this chapter does not contain any information.



WARNING

Incorrect disassembly

If the particle monitor is disassembled incorrectly during pressurization, there is a risk of leakage of media under high pressure.

- ▶ Be sure that all feed lines and the OPCom Particle Monitor are pressure-free.
- ▶ Check the existing state.
- ▶ Ensure that the machine is not turned on again.
- ▶ Disassemble the OPCom Particle Monitor.

19.1 Environment

Dispose of the packaging material according to the local regulations.

Careless disposal of the OPCom Particle Monitor and the pressure fluid can cause environmental pollution.

Dispose of the OPCom Particle Monitor and the pressure fluid in accordance with the national regulations of your country.

Dispose of the pressure fluid residues in accordance with the applicable safety data sheets for these hydraulic fluids.

Description	Order number
Data cable for computer connection <ul style="list-style-type: none"> › Side 1: M12 8-pole, 90° angled, IP67 › Side 2: D-Sub-plug 9-pole with additional coaxial power connector for power supply › Length: 5m, shielded › Temperature area -25°C...90°C › Oil-resistant 	SCSO 100-5030
Data cable with open ends <ul style="list-style-type: none"> › Side 1: M12 8-pole, 90° angled, IP67 › Side 2: open › Length: 5m, shielded › Temperature area -25°C...90°C › Oil-resistant 	SCSO 100-5020
Sensor connectors <ul style="list-style-type: none"> › M12 8-pole, straight, IP67 › Suitable for cable diameter 6...8 mm › Temperature area -20°C ... 85°C 	SCSO 100-5010
Adapter USB - RS232 serial <ul style="list-style-type: none"> › Side 1 (PC): USB A plug › Side 2 (Periphery): D-Sub-plug 9-pole › Length: 1,8m › Incl. driver CD for windows 98 / ME / 2000 / XP / Win 7 / Win 8 	PPCO 100-5420
Universal power supply <ul style="list-style-type: none"> › Supply range: 100...240VAC 50/60Hz › Output voltage: 24VDC / max. 0,63A / 15W › Operating temperature range: 0...40°C › Suitable for data cable SCSO 100-5030 › Supply line: Euro power cable 2-pole, 1,5m 	SCSO 100-5080
Ethernet - RS232 Gateway <ul style="list-style-type: none"> › Side 1: D-Sub-plug 9-pole › Side 2: RJ45 › 10/100 Mbps › Temperature range: 0...55°C › Power supply: 12...48VDC › Windows 95 / 98 / ME / NT / 2000 / XP / Vista / 7 / 8 	SCSO 100-5100
Display and storage device LubMon Visu <ul style="list-style-type: none"> › Suitable for installation in control cabinets › Visual display of measurement data via a display › Data logger with up to 1500 records › SD Card and USB Type B 	SCSO 900-1000
Minimess connector with volume flow regulation <ul style="list-style-type: none"> › Pressure range: 2 ... 50 bar › Pressure range: 50 ... 400 bar 	SPCO 300-5105 SPCO 300-5140
Flow control valve with Minimess connector	SPCO 300-5100

Table 41: Accessories

21. Troubleshooting

Error	Possible cause	Recommended measures
<ul style="list-style-type: none"> › No communication via RS232 or CAN-bus possible. › Current output < 4 mA 	Cable not properly connected	<ul style="list-style-type: none"> ▶ First check the electrical connection of the sensor, the data cable and power cable. ▶ Ensure that the connection is configured as prescribed.
	Operating voltage is outside of the prescribed range	<ul style="list-style-type: none"> ▶ Always operate the sensor in the range between 9 V and 33 VDC.
	Wrong configured communication bus	<ul style="list-style-type: none"> ▶ Check configuration in the menu "Communication"
<ul style="list-style-type: none"> › On all size channels, identical values are displayed. 	Air in the oil	<ul style="list-style-type: none"> ▶ Increase operating pressure within the specified range. ▶ Increase distance to the next pump / gear / cylinder.
<ul style="list-style-type: none"> › All size channels show the value 0/0/0/0 	No volume flow	<ul style="list-style-type: none"> ▶ Check inlet and outlet for correct installation. ▶ Increase operating pressure in the specified range.
	No valid measurement result available	<ul style="list-style-type: none"> ▶ Check configuration and measuring mode ▶ Make sure that a measurement starts and is completed
	Measuring cell contaminated (symbol [▶] flashes in display)	<ul style="list-style-type: none"> ▶ Clean OPCom Particle Monitor using clean oil or a solvent (e.g. isopropanol) ▶ Rinse with clean oil in the opposite direction.
	Measuring cell defective (symbol [▶]flashes in display)	<ul style="list-style-type: none"> ▶ Please contact ARGO-HYTOS service.
<ul style="list-style-type: none"> › Laser current high › Photo voltage low 	Air in the oil	<ul style="list-style-type: none"> ▶ Increase operating pressure in the specified range. ▶ Increase distance to the next pump / gear / cylinder.
	Measuring cell contaminated	<ul style="list-style-type: none"> ▶ Clean OPCom Particle Monitor using clean oil or a solvent (e.g. isopropanol) ▶ Rinse with clean oil in the opposite direction.
<ul style="list-style-type: none"> › The device permanently displays "no valid application". › The device repeatedly restarts. 	The basic system has a disorder. (All communication lines are automatically deactivated)	<ul style="list-style-type: none"> ▶ Please contact ARGO-HYTOS service.
<ul style="list-style-type: none"> › No serial communication 	Interface configuration is incorrect	<ul style="list-style-type: none"> ▶ Check and correct settings of the interface parameter if needed (9600, 8,1, N, N). ▶ Test communication using a terminal program.
	Wrong communication port selected	<ul style="list-style-type: none"> ▶ Check and correct the selection of the communication port (e.g. COM1)
	Incorrect spelling of sensor commands	<ul style="list-style-type: none"> ▶ Check the spelling of the sensor commands. Pay particular attention to upper case and lower case.
	NumLock key is disabled	<ul style="list-style-type: none"> ▶ Activate the NumLock key
	Caps lock key is activated (upper case)	<ul style="list-style-type: none"> ▶ Deactivate the Caps Lock
	Incorrect connection of cable or cable is defective	<ul style="list-style-type: none"> ▶ If possible, use the ARGO-HYTOS data cable

Table 42: Troubleshooting

Question	Answer
Why is there a warning triangle in the display? Why does the red LED light up?	An internal alarm has triggered. Compare the settings in the menu under "CONFIG. ALARM".
What is the measuring principle of the OPCOM Particle Monitor?	The particle monitor operates on the principle of light extinction. The shadow of particles is detected by means of a light source and a recipient.
Which electrical interfaces does the OPCOM Particle Monitor offer?	The particle monitor has a CAN, RS232 and a 4...20mA interface. CAN and RS232 cannot be operated simultaneously.
Which data loggers are available for this product?	LubMon PCLight, LubMon Visu and LubMonConnect.
How can the volume flow constantly be regulated in the specific range?	Generally, there must be no major changes in the volume flow during a measurement. If the system pressure is too high and thus also the volume flow through the particle monitor, additional accessories such as orifices or valves can be used. These can be purchased from ARGO-HYTOS.
Where to install orifices and valves?	Installation must always be performed downstream of the particle monitor. This results in a dynamic pressure which prevents outgassing of air.
Is the device compatible with LABS?	No, the device is calibrated with oil and can therefore not be used in food processing.
Is the device ATEX compliant?	The basic unit does not meet any ATEX directives, an ATEX version is in development.
To which standard is the device calibrated?	The device is calibrated according to ISO 11943. The equipment used for the calibration was primarily calibrated according to ISO 11171 and is thus traceable to NIST SRM 2806A.
How can the device be cleaned?	Clean OPCOM Particle Monitor using clean oil or a solvent (e.g. isopropanol) Rinse with clean oil in opposite direction.
What is the volume flow index?	The volume flow index is an internal value to calculate the particle concentration. This is not the actual volume flow.
How high is the measurement deviation beyond the specified measuring range?	This measurement deviation cannot be specified. The device must be operated within the specified range.
How long is the calibration certificate valid?	The validity of the initial calibration is 18 months. After this period or with subsequent calibration, the validity is limited to 12 months.
Which COM port is used at a serial-USB converter?	This depends on the computer to which the converter is connected. Check the COM port in your hardware settings on the computer.
How to set the measuring time?	The measuring time depends on the application. Usually 60 seconds are preferable (factory setting). With a very small contamination of the medium, the measuring time can be increased accordingly.
What is the difference between a particle counter and a particle monitor?	A particle counter counts all particles in the oil that flows through it. A particle monitor detects only one defined part of the particles and calculates the total amount.
Can customers calibrate the device on their own?	No. For calibration of the device, sound knowledge is necessary.
Does the device have a real-time clock (RTC)?	No, there is no RTC. The device has an internal counter of operating hours.
How can the device be configured?	The device provides a variety of settings. For further information see the manual.
Is there a device without display?	Yes, such a device is available.

Question	Answer
Is it necessary to monitor the measuring equipment?	Depending on the user / operator. If the measuring data is used for further purposes, mostly yes.
Where is the ideal installation point in a system?	The installation / measuring point should reflect the overall condition of the system. Installation after a filter, pump or long hoses and pipes should be avoided. There must be a constant oil pressure.
Is the device compatible with diesel fuels?	Yes, the device is compatible.
Is the device compatible with phosphate ester / skydrol?	The standard version of the OPCom is not skydrol resistant. For measuring skydrol, the phosphate ester version must be used.
Can CAN and RS232 be used in parallel?	No, there is only the possibility of applying one type of communication. Parallel operation is not possible.
Is the device compatible with rapeseed oil?	There is only a slight effect of the medium on the resistance of internal seals, which, however, can lead to a malfunction of the part in the long term.

Table 43: FAQ

23.1 Technical data

Sensor data	Size	Unit
Max. operating pressure		
dynamic	420	bar
static	600	bar
Permissible flow rate	50...400	ml/min
Operating conditions:		
Temperature	-20...85	°C
Rel. humidity (non-condensing)	0...100	% r.H.
Display readable up to	60	°C
Compatible fluids	Mineral oils (H, HL, HLP, HLPD, HVLP), synthetic esters (HETG, HEPG, HEES, HEPR), polyalkylenglycols (PAG), zinc and ash-free oils (ZAF), polyalphaolefins (PAO)	
Wetted materials	Stainless steel, sapphire, chrome, NBR, minimess coupling: Zinc / nickel	
Protection class ¹⁾	IP67	
Power supply	9...33	V
Power input	max. 0,3	A
Max. power consumption	2	W
Output		
Power output ²⁾	4...20	mA
Accuracy power output ³⁾	±2	%
Interfaces	RS232 / CAN	-
Alarm contact	Open Collector	-
Digital input for start and stop		
Power supply	9...33	V
Data memory	3000	data records
Connecting dimensions		
Fluid connections	G¼ minimess M 16x2	inch
Electrical connection	M 12 x 1, 8-pole	-
Tightening torque M12 - connection	0,1	Nm
Measuring range acc. to ISO 4406:17		
Cleanliness level (measuring range)	0...24	Ordinal number (OZ)
Cleanliness level (calibrated range)	10...22	Ordinal number (OZ)
Measuring accuracy (calibrated range)	±1	Ordinal number (OZ)
Weight	~720	g

Table 44: Technical data

¹⁾ With screwed-on connector²⁾ Output IOut is freely configurable (see interfaces and communication commands)³⁾ In relation to the analogue current signal (4 ... 20 mA)

23.2 Dimensional drawing



Abb. 32: Dimensional drawing

24.1 Cable lengths

The tables show the maximum cable lengths for different transmission rates.

Baud rate	Max. cable length
9600	150 m
19200	15 m
57600	5 m
115200	<2 m

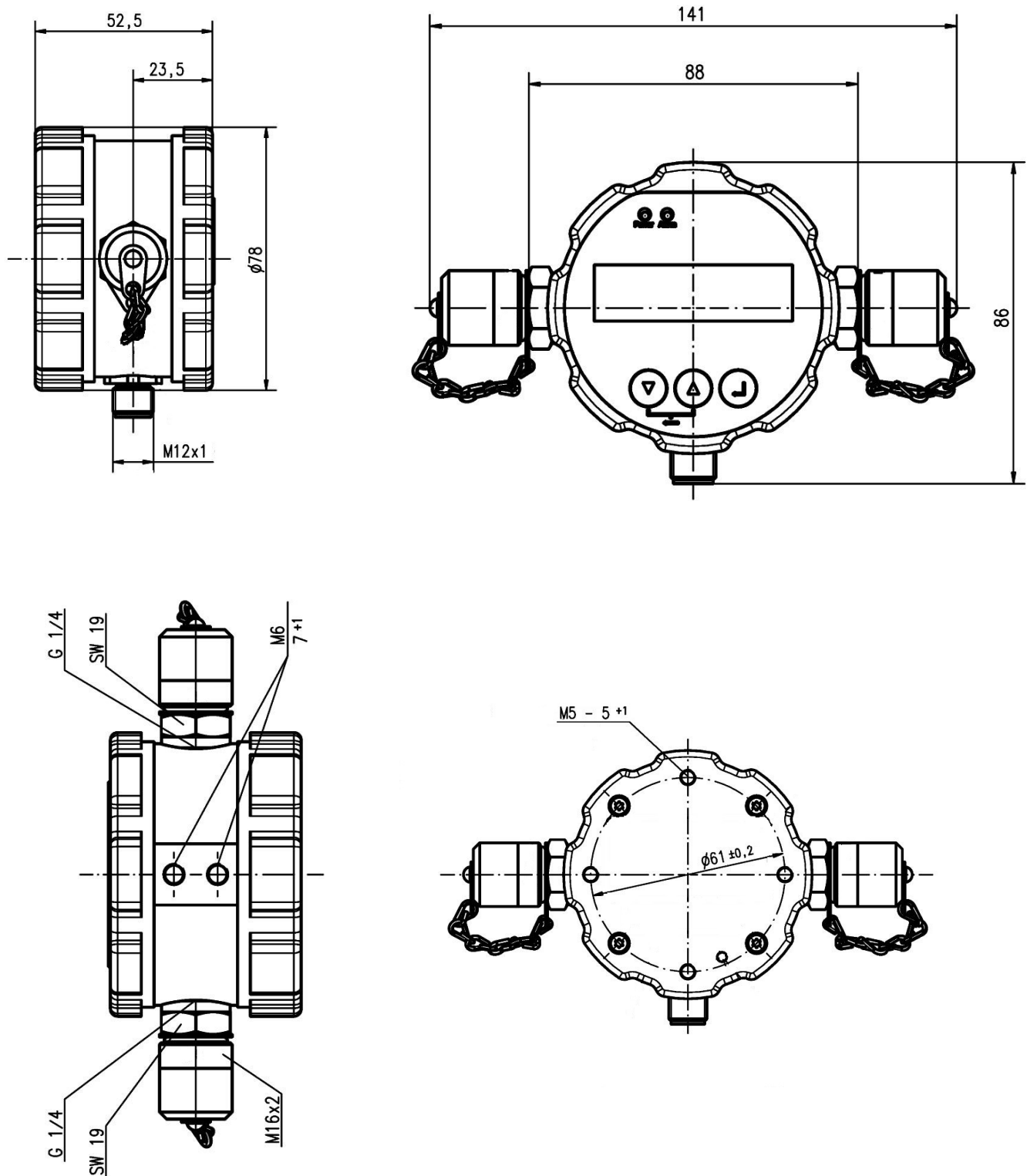
Table 45: Cable lengths RS 232

24.2 Coding of error bits

Every ERC is displayed in hexadecimal notation and consists of four characters (0-F). The conversion for each character is based on the following tables.

hexadecimal	binary
0	0000
1	0001
2	0010
3	0011
4	0100
5	0101
6	0110
7	0111
8	1000
9	1001
A	1010
B	1011
C	1100
D	1101
E	1110
F	1111

Table 46: Calculation hexadecimal to binary

Bit Nr.	MSB 15	14	13	12	11	10	9	8
ERC 1	--	--	--	--	ISO(i+1)>= ISO(i)	Flow too small	Flow too high	Concentration >=ISO 23
ERC2	--	--	--	--	--	--	--	--
ERC3	--	--	--	--	--	--	--	--
ERC4	Temperature alarm	Concentration alarm	Power Up = 1 before first measurement	Alarm mode 0= Standard 1= Filter	Measuring mode = button	Measuring mode = Digital I/O	Measuring mode = time controlled	Running measurement

7	6	5	4	3	2	1	LSB 0
--	--	--	--	--	--	--	--
--	--	--	--	--	--	Last threshold Calibration (S5) reached	First threshold Calibration (S1) reached
--	--	--	--	--	--	--	--
Meas. mode = Automatic	--	Temperature <-20°C	Temperature >80°C	Detector voltage too high	Detector voltage too small	Laser current too small	Laser current too high

Table 47: ERC Decoding table

ERC 0x	1				0				2				A			
Binary	0	0	0	1	0	0	0	0	0	0	1	0	1	0	1	0
Bit No.	15	14	13	12	11	10	9	8	7	6	5	4	3	2	1	0

Table 48: Example of an ERC decoding

Meaning:

- Bit 1 = 1 → Laser current too small
- Bit 3 = 1 → Detector voltage too high
- Bit 5 = 1 → Temperature <-20°C
- Bit 12 = 1 → Alarm mode = filter

24.3 Particle contaminations

The required oil cleanliness in the system depends on the components that are most sensitive to contaminants. If the component manufacturers do not give any specific information about the required oil cleanliness or filter fineness, it is recommended to determine the oil cleanliness on the basis of the tables shown below:

The listed reference values for standard components refer to a pressure range from 160 to 210 bar.

System components	Required oil cleanliness according to ISO 4406	
Pumps	Axial piston pumps	21 / 18 / 15
	Radial piston pumps	21 / 18 / 15
	Gear pumps	21 / 18 / 15
	Vane pumps	20 / 17 / 14
Motors	Axial piston motors	21 / 18 / 15
	Radial piston motors	21 / 18 / 15
	Gear motors	21 / 18 / 15
	Vane motors	20 / 17 / 14
Valves	Directional control valves	21 / 18 / 15
	Pressure valves	21 / 18 / 15
	Flow control valves	21 / 18 / 15
	Check valves	21 / 18 / 15
	Proportional valves	20 / 17 / 14

Table 49: Cleanliness class for system components

If the operating pressure in the system is increased, it is necessary to improve the oil cleanliness, to ensure the same wear resistance of the components as with normal pressure.

The following table shows the required change in oil cleanliness, when the operating pressure changes in relation to the basic pressure range of 160 to 210 bar.

Operating pressure in bar	Change in oil cleanliness
<100	3 classes worse
100 ... 160	1 class worse
160 ... 210	None
210 ... 250	1 class better
250 ... 315	2 classes better
315 ... 420	3 classes better
420 ... 500	4 classes better
500 ... 630	5 classes better

Table 50: Change of the cleanliness classes at different operating pressures

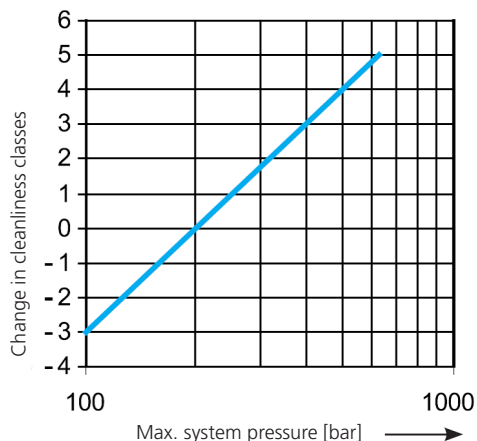

Fig. 33: Change of the cleanliness classes at different operating pressures

Example:

In a system with a gear pump and proportional valves, an oil cleanliness of 20/17/14 according to ISO 4406 for an operating pressure of 210 bar is necessary. If the operating pressure is increased to 250 bar, the table shows that the cleanliness of the oil needs to be reduced by one class to 19/16/13. The required oil cleanliness is also determined by other influencing variables:

- › Expected life time of the machine
- › Costs for repairs / spare parts
- › Costs due to downtime and interruptions
- › Requirements for the safety of the system (these are not only influenced by the oil cleanliness)

If one of these aspects is particularly important, the required oil cleanliness should be improved by one class. If two or more criteria are important, the oil cleanliness should be improved by two classes.

International

ARGO-HYTOS worldwide

Benelux	ARGO-HYTOS B.V.	info.benelux@argo-hytos.com
Brazil	ARGO-HYTOS Fluid Power Systems Ltda.	info.br@argo-hytos.com
China	ARGO-HYTOS Fluid Power Systems	info.cn@argo-hytos.com
Czech Republic	ARGO-HYTOS s.r.o	info.cz@argo-hytos.com
	ARGO-HYTOS Protech s.r.o	info.protech@argo-hytos.com
France	ARGO-HYTOS SAS	info.fr@argo-hytos.com
Germany	ARGO-HYTOS GMBH	info.de@argo-hytos.com
Great Britain	ARGO-HYTOS Ltd.	info.uk@argo-hytos.com
Hong Kong	ARGO-HYTOS Hong Kong Ltd.	info.hk@argo-hytos.com
India	ARGO-HYTOS PVT. LTD.	info.in@argo-hytos.com
Italy	ARGO-HYTOS S.r.l.	info.it@argo-hytos.com
Poland	ARGO-HYTOS Polska spz o.o.	info.pl@argo-hytos.com
Sweden	ARGO-HYTOS Nordic AB	info.se@argo-hytos.com
Turkey	ARGO-HYTOS Hidrolik Ekip. San. ve Tic. Ltd. Şti.	info.tr@argo-hytos.com
USA	ARGO-HYTOS Inc.	info.us@argo-hytos.com

