

## Off-line Filter Unit

FNA 045



### Safety and operating instructions

**Read safety and operating instructions before use.**

**Note:**

The indicated data only serve to describe the product.  
Specifications regarding the use of this product are only examples and suggestions.  
Catalog specifications are no guaranteed features.  
The information given does not release the user from his / her own assessments and inspection.  
Our products are subject to a process of natural wear and aging.

© All rights are reserved by ARGO-HYTOS GMBH, even in the event of industrial property rights.  
Any right of disposal such as copying and distribution rights shall remain with us.

The picture on the title page shows a configuration example.  
The delivered product may thus differ from the illustration.

The device conforms with the **CE** requirements.

# Contents

<b>Contents</b> .....	<b>3</b>
<b>1. About this documentation</b> .....	<b>4</b>
1.1 Applicability of this documentation .....	4
1.2 Required and supplementary documentation .....	4
1.3 Presentation of information .....	4
<b>2. Safety instructions</b> .....	<b>6</b>
2.1 About this chapter .....	6
2.2 Intended use .....	6
2.3 Improper use .....	6
2.4 Reasonably foreseeable misuse .....	6
2.5 Qualification of personnel .....	6
2.6 General safety instructions .....	7
2.7 Product and technology related safety instructions .....	7
<b>3. General instructions</b> .....	<b>8</b>
<b>4. Scope of delivery</b> .....	<b>9</b>
<b>5. About this product</b> .....	<b>10</b>
5.1 Performance specification .....	10
5.2 Device description .....	10
5.3 Component overview .....	10
5.4 Identification of the product .....	11
<b>6. Transport and storage</b> .....	<b>12</b>
<b>7. Assembly</b> .....	<b>13</b>
<b>8. Commissioning</b> .....	<b>14</b>
8.1 Before commissioning .....	14
8.2 After switching on .....	14
8.3 In case of power failure .....	14
<b>9. Operation</b> .....	<b>16</b>
<b>10. Repair and maintenance</b> .....	<b>17</b>
10.1 Maintenance .....	18
10.2 Maintenance overview .....	18
10.3 Replacing the filter element .....	18
10.4 Replacing the pump and the motor .....	19
10.5 Replacing the suction filter element / pump protection filter .....	21
<b>11. Decommissioning</b> .....	<b>22</b>
<b>12. Disassembly</b> .....	<b>23</b>
<b>13. Disposal</b> .....	<b>24</b>
<b>14. Troubleshooting</b> .....	<b>25</b>
14.1 How to proceed .....	25
14.2. Fault table .....	25

<b>15. Technical data</b> .....	<b>26</b>
15.1 Device dimensions .....	26
15.2 Technical data .....	27
15.3 Operating conditions .....	28
15.4 Hydraulic circuit diagram.....	28
15.5 Connection diagram .....	29
<b>16. Appendix</b> .....	<b>30</b>
16.1 <b>Installation declaration</b> .....	30
16.2 Spare parts list .....	31

## 1. About this documentation

### 1.1 Applicability of this documentation

This documentation is applicable for the following product:

- › Off-line Filter Unit FNA 045

This documentation is written for technicians, operators, service engineers and system operators.

This document contains important information for safe and appropriate assembly, transport, activation, operation, usage, servicing, dismantling and simple troubleshooting.

- › Read this document completely and in particular Chapter 2, "Safety Instructions", before you work with the product.

### 1.2 Required and supplementary documentation

Do not commission the product until you have received the documentation marked with the book icon and before you have understood and complied with the information therein.

	Title	Number of document	1.2.1 Document type
	Data sheet	80.50-e	PDF

Table 1: Required and supplementary documentation

### 1.3 Presentation of information

So that this document can help you to work quickly and safely with your product, we use standardized safety instructions, symbols, terms and abbreviations. For better understanding, these are explained in the following sections.

#### 1.3.1 Safety instructions

In this documentation, safety instructions are faced with a sequence of actions which would result in the danger of personal injury or damage to equipment. The measures described to avoid these hazards must be observed.

 <b>DANGER</b>	
	<b>Type and source of danger</b> <ul style="list-style-type: none"><li>› Consequences of the danger</li><li>› Escaping or averting the danger</li><li>› Rescue (optional)</li></ul>

- › Warning signal: draws attention to the danger
- › Signal word: indicates the severity of the danger
- › Type and source of danger: specifies the type and source of danger
- › Consequences: describes the consequences in the event of non-compliance
- › Action: indicates how the danger can be avoided



Warning sign, signal word	Meaning
 <b>DANGER</b>	Indicates a dangerous situation which results in death or serious injury if not avoided.
 <b>WARNING</b>	Indicates a dangerous situation which may result in death or serious bodily injury if not avoided.
 <b>CAUTION</b>	Indicates a dangerous situation which may result in light to moderate injury if not avoided.
<b>NOTE</b>	Indicates property damage: The product or surrounding could be damaged.

Table 2: Meaning of the warning signs

### 1.3.2 Symbols

The following symbols indicate notes which are not safety-relevant but increase the intelligibility of the documentation.









Symbol	Meaning
	If this information is not observed, the product cannot optimally be used or operated
>	Singular, independent action step / instruction
1. 2. 3.	Numbered instruction The numbers indicate that the action steps follow one another
	This symbol indicates danger to equipment, material and environment
	This symbol indicates the risk of personal injury (minor injury).
	This symbol indicates the risk of personal injury (death, serious bodily injury).
	This symbol specifies that protective gloves should be worn.
	This symbol specifies that safety shoes should be worn.
	This symbol specifies that protective goggles should be worn.
	This symbol specifies that the unit should be disconnected from the power supply.

Table 3: Meaning of symbols

### 1.3.3 Terms

In this documentation the following terms are used:

Term	Meaning

Table 4: Terms

### 1.3.4 Abbreviations

In this documentation the following abbreviations are used:

Term	Meaning
FNA	Off-line Filter Unit

Table 5: Abbreviations

## 2. Safety instructions

### 2.1 About this chapter

This product was manufactured according to the generally recognized standards of engineering. Nevertheless, there is a danger of injury or damage if you do not observe this chapter and the safety instructions in this documentation.

- › Read this document thoroughly and completely before working with the product.
- › Retain this document and ensure that it is available for all users at all times.
- › Always include the necessary documentation when passing the equipment along to a third party.

### 2.2 Intended use

This product is a hydraulic component.

You may use the product for the following:

- › for filtration of hydraulic fluids in the bypass flow on machines and systems, taking account of the technical data.

This product is intended for professional use only and not for private use.

"Intended use" also includes that you have completely read and understood this documentation, in particular Chapter 2 "Safety Instructions".

### 2.3 Improper use

Any other use than the intended use described, is improper and inadmissible.

If unsuitable products are installed or used in safety-related applications, unintended operating states may occur in the application, which may cause personal injury and / or property damage.

Therefore only use this product in safety-related applications if this use is explicitly specified and permitted in the product documentation, e.g. in explosion protection areas or in safety-related parts of a control system (functional safety).

ARGO-HYTOS GMBH assumes no liability for damages resulting from improper use.

The risks associated with improper use are solely with the user.

### 2.4 Reasonably foreseeable misuse

The delivery of the following media is forbidden:

- › others than listed in Chapter 16 "Technical data".

Especially

- › flammable liquids such as petrol or thinner (explosion hazard)
- › foodstuffs
- › The device is not suitable for sucking sludge and sediment.

The operator alone is liable for damages resulting from improper use.

### 2.5 Qualification of personnel

The operations described in this document require fundamental knowledge of mechanics and hydraulics as well as knowledge of the appropriate technical terms. In order to ensure safe use, these operations may therefore only be carried out by a correspondingly skilled worker or an instructed person under the guidance of a skilled worker.





A skilled worker is someone who can - based on his / her technical education, knowledge and experience as well as knowledge of the respective regulations of the jobs assigned to him / her - recognize possible dangers and ensure appropriate safety measures.

A skilled worker must observe the relevant technical regulations.

## 2.6 General safety instructions

- › Observe the valid regulations for accident prevention and environmental protection.
- › Observe the safety regulations and requirements of the country in which the product is used / applied.
- › Only use ARGO-HYTOS products that are in technically perfect condition.
- › Observe all instructions on the product.
- › People who assemble, operate, disassemble or maintain ARGO-HYTOS products may not do so under the influence of alcohol, other drugs or medications that affect the responsiveness.
- › Only use manufacturer-approved accessories and spare parts, in order to prevent personal danger due to unsuitable spare parts.
- › Observe the technical data and ambient specifications specified in the product documentation.
- › If unsuitable products are used or installed in safety-relevant applications, unintended operating states may occur in the application, which can cause personal injury and / or material damage. Therefore only use the product in safety-relevant applications if this use is explicitly specified and permitted in the product documentation.
- › You may only put the product into operation, when it has been established that the final product (e.g. a machine or system), into which the ARGO-HYTOS products have been installed, complies with the country-specific regulations, safety regulations and standards of the application.

## 2.7 Product and technology related safety instructions

 <b>CAUTION</b>	
	<p><b>Leaked hydraulic oil</b> <b>Environmental hazard / risk of slipping</b></p> <ul style="list-style-type: none"><li>› In case of spills, cover the oil-covered surface immediately with an oil-binding medium.</li><li>› Then immediately dispose of the oil-binding medium according to the national environmental regulations.</li></ul>
	<p><b>Ignition hazard</b> <b>Risk of electrostatic charge by poorly conducting hydraulic fluid.</b></p> <ul style="list-style-type: none"><li>› If the electrical conductivity of the hydraulic fluid is not known, please contact the manufacturer of the hydraulic fluid.</li></ul>
	<p><b>Risk of burns</b> <b>Contact temperatures according to DIN EN563 (3) and DIN EN13202 (4) may be exceeded during operation.</b></p> <ul style="list-style-type: none"><li>› Allow the off-line filter unit to cool down before touching it.</li></ul>

#### 3.1 For prevention of material damage and product damage



**CAUTION**



**Danger due to improper handling**

**Property damage**

- › The filter unit may only be used in accordance with Section 2.2, "Intended use".

**Leakage or spillage of hydraulic fluid**

**Environmental pollution and ground water contamination**

- › Use oil binding agents in order to bind leaked hydraulic oil.



**Risk of burns**

**Contact temperatures according to DIN EN563 (3) and DIN EN13202 (4) may be exceeded during operation.**

- › Allow the off-line filter unit to cool down before touching it.

**Contamination due to fluids and foreign bodies**

**Premature wear, malfunction, risk of damage, property damage.**

- › Ensure cleanliness during installation in order to prevent foreign bodies, such as welding beads or metal chips, from entering the hydraulic lines, leading to premature wear or malfunction.
- › Make sure that connections, hydraulic lines and attachment parts (e.g. gauges) are free from dirt and chips.
- › Prior to commissioning, check that all hydraulic and mechanical connections are connected and tight, and that all gaskets and seals of the plug connectors are correctly assembled and undamaged.
- › For removal of lubricants and other contaminants, use residue-free industrial wipes.
- › Make sure that all connections, hydraulic lines and attachment parts are clean.
- › Ensure that no contaminants enter when closing the connections.
- › Make sure that no detergents enter the hydraulic system.
- › Do not use cotton waste or faying cleaning rags for cleaning.
- › Do not use hemp as sealing agent.



**Improper cleaning**

**Premature wear, malfunction, risk of damage, property damage.**

- › Close all openings with appropriate protective fittings to prevent penetration of detergents.
- › Do not use aggressive cleaning agents for cleaning. Clean the product with a suitable cleaning fluid.
- › Do not use a high pressure cleaner.
- › Do not use compressed air to clean function interfaces such as seal areas.



## 4. Scope of delivery

---

### The package includes:

- › 1 Off-line Filter Unit FNA 045
- › 1 Operating manual

## 5. About this product

### 5.1 Performance specification

The off-line filter unit FNA 045 is a stationary filter unit for filtration of hydraulic fluids and lubricants with a viscosity of 15 mm<sup>2</sup>/s - 600 mm<sup>2</sup>/s (in continuous operation).

A separate installation in the bypass or cooling circuit for fine filtration and discharge of the full flow filter is just as possible as the filtration of fresh oil and the cleaning (flushing) of polluted systems for wear protection of components and systems.

The volume flow is 45 l/min (50 Hz) and 54 l/min (60 Hz) respectively.

The operating temperature is in the range of 0 °C to 65 °C.

### 5.2 Device description

The off-line filter unit FNA 040 consists of an electrically operated filter pump with exchangeable filter element and may be equipped with an electrical maintenance indicator. The control box of the pump motor is used to connect the power supply. The suction hose may be connected to the suction port of the pump and the pressure hose at the outlet of the main filter.

### 5.3 Component overview



Fig. 1: Component overview

- |                                      |                                      |
|--------------------------------------|--------------------------------------|
| 1 Block                              | 6 Filter housing with filter element |
| 2 Fluid outlet / pressure connection | 7 Fluid inlet / suction connection   |
| 3 Rotary switch                      | 8 Differential pressure switch       |
| 4 Motor                              | 9 Closure suction filter             |
| 5 Filter cover                       | 10 Nameplate                         |

#### 5.4 Identification of the product

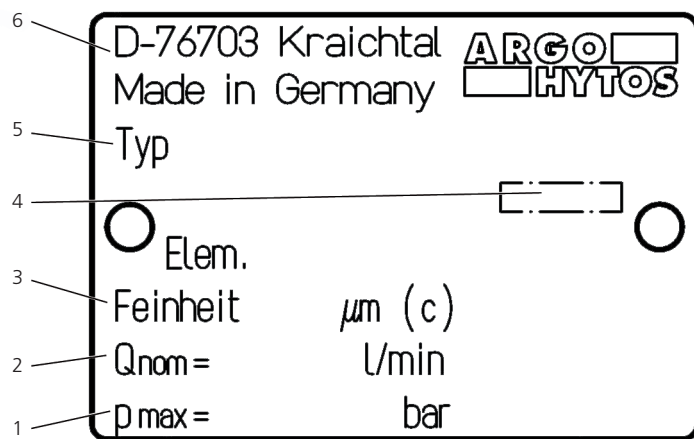

Fig. 2: Nameplate

- |   |                     |   |                     |
|---|---------------------|---|---------------------|
| 1 | Max. pressure       | 4 | Year of manufacture |
| 2 | Nominal volume flow | 5 | Type designation    |
| 3 | Filter fineness     | 6 | Address             |

#### NOTE

Nameplates are documents which must not be changed or removed.

- › Damaged or lost nameplates immediately have to be replaced true to the original.

## 6. Transport and storage

### 6.1 Transport



**Falling unit through incorrect transport  
Injury and property damage**

- › The unit must be carried manually by two persons due to its own weight of 37 kg.
- › Wear safety shoes when transporting the filter unit.

- › When using mobile transport aids, ensure a secure position of the unit (danger of tipping).
- › During transport, close the suction and pressure port, in order to avoid a possible leakage of residual oil.

### 6.2 Storage

The off-line filter unit FNA 045 should be stored in a in an enclosed space, to protect it from moisture and condensation.



**Risks related to chemical reactions**

**Risk of injury**

**Chemical substances in the immediate vicinity of the off-line filter unit may react and lead to destruction of the device and to injuries of persons who are in the immediate vicinity of the device.**

- › Storage in the immediate vicinity of chemically active substances such as acids, alkalis, salts, organic solvents and rechargeable batteries is prohibited.

The ambient temperature during storage of the off-line filter unit FNA 045 should be between + 5 °C and + 30 °C at a humidity of 80 %. Before storage over a period of more than 6 months, the unit should be filled with oil in order to preserve it against corrosion.



**Faulty power supply  
Risk of death and injury**

- › Always consider the country-specific regulations.

Let - prior to commissioning - an electrician check whether:

- › the mains voltage matches with the voltage specified on the type plate of the motor,
- › the power source has appropriately been secured,
- › the cross-section is of sufficient size,
- › cable and connection to the power source are in perfect condition.

With 3-phase AC motors check after connecting that:

- › when switching on, the direction of rotation matches with the direction arrow on the motor, if not, have it changed by an electrician.

Specifically, proceed with the following steps:

- › connect the motor to the local power supply.

### 8.1 Before commissioning

- › Be sure to read and understand the operating manual before putting the device into operation.
- › The information for intended use, the operating conditions and the technical specifications must be adhered to.
- › Fasten the unit sufficiently safely and vibration-free only using rubber buffers (Order no. UM 045.0709) (MA 30 +5 Nm).
- › Cables and hoses must be outside of the movement range of the operating personnel (tripping hazard).
- › If no hydraulic oil is sucked in during commissioning, switch off the unit, open the cover at the filter housing and fill in approx. 0,5 l hydraulic oil.
- › The oil to be filtered must be compatible with the previously filtered hydraulic oil. If this is not the case, the filter unit must be cleaned and the filter element is to be replaced (see filter element change).
- › When using the hoses during unmanned operation, ensure that they might not fall out of the container.
- › Recommended nominal sizes of the hydraulic connections:
  - » Suction hose / suction pipe DN 32
  - » Pressure hose / pressure pipe DN 25
- › The suction and discharge pipe must be immersed far enough below the liquid level, so that oil is sucked in.
- › The hydraulic fluid must be free of water (no oil turbidity).
- › Properly close the cover of the filter housing.
- › Manually turn the cover until it stops; a gap between cover and housing may remain visible (see Figure 3).

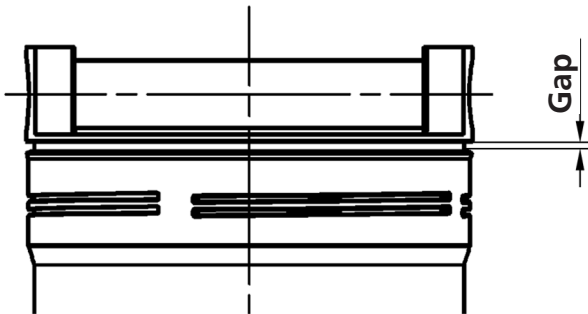

Fig. 3: Gap at the filter cover

### 8.2 After switching on

- › With 3-phase AC motors check after connecting if the direction of rotation matches with the direction arrow on the motor. If not, have it changed by an electrician.
- › Check the off-line filter unit for leaks.

### 8.3 In case of power failure

In order to prevent unintentional starting of the unit, always switch off and unplug the unit.

#### CAUTION



#### **Danger by improper handling**

#### **Material damage**

- › The off-line filter unit should be equipped with a suction strainer on the suction side. A missing or defective suction strainer (Order No. see below) can lead to pump damage. In this case the manufacturer assumes no liability.
- › With assembly of the off-line filter units, a clogging indicator has to be used. Without clogging indicator, clogging of the element cannot be observed.

Installation position	vertical
Fixing	Fixing only with rubber buffers (Order No. UM 045.0709)
Extension height filter element	min. 700 mm
Connection recommendation for pipeworks	All cut-ring and progressive-ring fittings of series L or LL from ERMETO EO-standard program according to DIN 2353/ISO 8434-1
Connection recommendation for hoses Suction connection- $\varnothing$ (inlet)	min. DN 32 only use spiral hose All cut-ring and progressive-ring fittings of series L or LL from ERMETO EO-standard program according to DIN 2353/ISO 8434-1
Connection recommendation for hoses Pressure connection- $\varnothing$ (outlet)	min. DN 25
Suction height	max. 2.0 m (unfilled condition)
Pump protection	Use of suction strainer mandatory / fineness 280 $\mu$ m (Order No. S9.0417-13)
Max. cleaning performance	Distance between suction and pressure side to be kept as large as possible (no short-circuit of the oil flow).

Table 6: Installation recommendations

**! CAUTION**



**Exposure to spilled oil  
Injury - risk of slipping**

› If oil leaks, the oil-covered area must be shut off immediately and covered with an oil binding medium (risk of slipping).



**Static charge  
Sparking**

› There is a risk of static charge when using poorly conducting hydraulic or lubricating oils. In this case, please consult the manufacturer.

**9.1 Filtering hydraulic fluids in the bypass flow**

1. Connect the filter unit to a power source.
2. Place the suction line into the container of the machine or system (e.g. hydraulic tank).
3. Place the pressure line of the pressure limiting valve in the container of the machine or system (e.g. hydraulic tank).
4. Turn the rotary switch to Pos. II

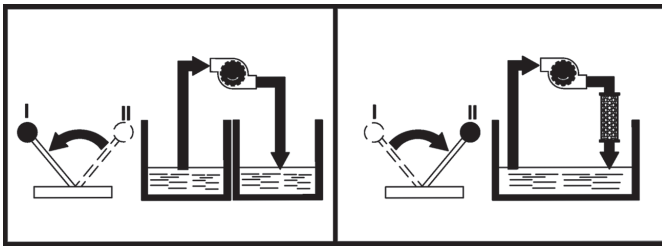

5. Turn on the power supply and plug in the mains plug.
6. Check the oil flow on possibly insufficient immersion depth of the suction pipe in the oil tank.

**NOTE**

**Faulty insertion of the discharge pipe**

- › At the beginning of the filtration, filling of the off-line filter unit may take a few seconds.
7. Using the clogging indicator, check the element for clogging at operating temperature of the medium used.
  8. At the end of filtration, pull the suction strainer out of the container of the machine or unit (e.g. hydraulic tank) and draw in air for max. 30 seconds. Thus, residual oil from the filter housing and the lines above oil level will be returned via the discharge pipe into the tank of the machine or unit.
  9. Turn off the power supply and unplug the mains plug.

**NOTE**

**Reaching the maximum cleaning performance**

- › In order to prevent a short circuit of the oil flow, the distance between the suction and pressure connection should be kept as large as possible.



 **DANGER**



**Danger to life**  
**Risk of electric shock**

During repair work, turn off the unit and pull the mains plug.

 **CAUTION**



**Risks related to chemical reactions**

**Risk of injury**

- › Chemical substances in the immediate vicinity of the filter unit may react and lead to destruction of the device and to injuries of persons who are in the immediate vicinity of the device
- › Storage in the immediate vicinity of chemically active substances such as acids, alkalis, salts, organic solvents and rechargeable batteries is prohibited.



**Hydraulic oil spills**

**Environmental hazard / risk of slipping**

- › Before maintenance and repair work, completely drain the unit.
- › In case of spills, cover the oil-covered surface immediately with an oil-binding medium.
- › Then immediately dispose of the oil-binding medium according to the national environmental regulations.



**Ignition hazard**

**Risk of electrostatic charge by poorly conducting hydraulic fluid**

- › If the electrical conductivity of the hydraulic fluid is not known, please contact the manufacturer of the hydraulic fluid.



**Risk of burns**

**Contact temperatures according to DIN EN563 (3) and DIN EN13202 (4) may be exceeded during operation.**

- › Allow the filter unit to cool down before touching it.

**NOTE**

**Impaired function by dirt ingress into the pump**

**The function of the filter unit is no longer guaranteed.**

- › During repair work, all parts coming in contact with the hydraulic medium, must be kept free of dirt and chips.

## 10.1 Maintenance

### 10.2 Maintenance overview

Maintenance work	Part No.	Maintenance interval
Checking / changing the filter element	V7.1560-103(3µm) V7.1560-03 (5µm) V7.1560-06 (10µm) Y7.1560-05 (Aqua Element)	As soon as the clogging indicator turns into the red area within the permitted viscosity range.
Checking / changing the suction filter element	S9.0417-13	quarterly or with corresponding peculiarities (lower volume rate with clean filter element, too loud operating noise)

Table 7: Maintenance overview

### 10.3 Replacing the filter element

1. Pump the filter element empty - (see Chapter 9.1 "Filtering liquids in the bypass flow" Point 7)
2. Disconnect the off-line filter unit from the power supply and unplug the mains plug.

<b>! CAUTION</b>	
	<p><b>Risk of burns</b> Contact temperature according to DIN EN563 (3) and DIN EN13202 (4) may be exceeded during operation.</p> <p>› Allow the filter unit to cool down before touching it.</p>

#### 10.3.1 Removing the filter element

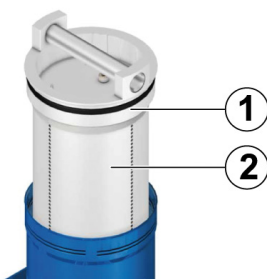

Fig. 4: Removing the filter element

1. Turn the housing cover (1) counterclockwise.
2. Carefully remove the cover (1) with the filter element (2) from the filter tube. (The filter element is attached to the cover. Let the draining oil drip off into the housing.)

#### 10.3.2 Removing the filter element from the cover



Fig. 5: Removing the filter element from the cover

1. Push the filter element at the cover in arrow direction 1 and remove it in arrow direction 2.
2. Dispose of the filter element according to the national environmental legislation (Waste code: Oil filter 16 01 07).

### 10.3.3 Attaching the filter element

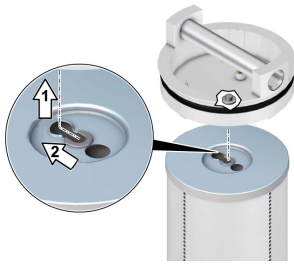

Fig. 6: Attaching the filter element

1. Check the filter element type number.  
Does the laser inscription on the filter element match with the indications on the type plate or in the operating manual?
2. Attach the filter element in arrow direction 2 and lock it in arrow direction 1.

### 10.3.4 Installing the filter element

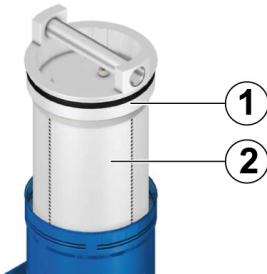

Fig. 7: Installing the filter element

1. Carefully insert the cover (1) with the filter element (2) into the filter tube.
2. Screw in the cover manually until it stops.  
A gap between cover and filter pipe may remain visible (see Chapter 8.1 "Before commissioning" / Fig. 3)

## 10.4 Replacing the pump and the motor

<b>DANGER</b>	
	<p><b>Danger to life</b> <b>Risk of electric shock</b></p> <ul style="list-style-type: none"> <li>› Before uninstalling, disconnect the device from the power supply and pull the mains plug. Uninstalling may only be carried out by qualified electricians.</li> <li>› Electrical work on the off-line filter units has strictly to be carried out by qualified electricians. Danger of electrical shock.</li> </ul>
	<p><b>Risk of injury</b> <b>Risk of injury by incorrect handling</b></p> <ul style="list-style-type: none"> <li>› Uninstalling may only be carried out by instructed persons.</li> </ul>
<b>CAUTION</b>	
	<p><b>Risk of burns</b> <b>Contact temperatures according to DIN EN563 (3) and DIN EN13202 (4) may be exceeded during operation.</b></p> <ul style="list-style-type: none"> <li>› Allow the filter unit to cool down before touching it.</li> </ul>
	<p><b>Risk of functional impairment</b> <b>In case of dirt ingress into the pump during maintenance work, optimal functioning of the device is no longer guaranteed (no manufacturer liability).</b></p> <ul style="list-style-type: none"> <li>› Work with special care when replacing the pump / motor.</li> <li>› All parts coming into contact with the hydraulic medium must be kept free from dirt and chips.</li> </ul>

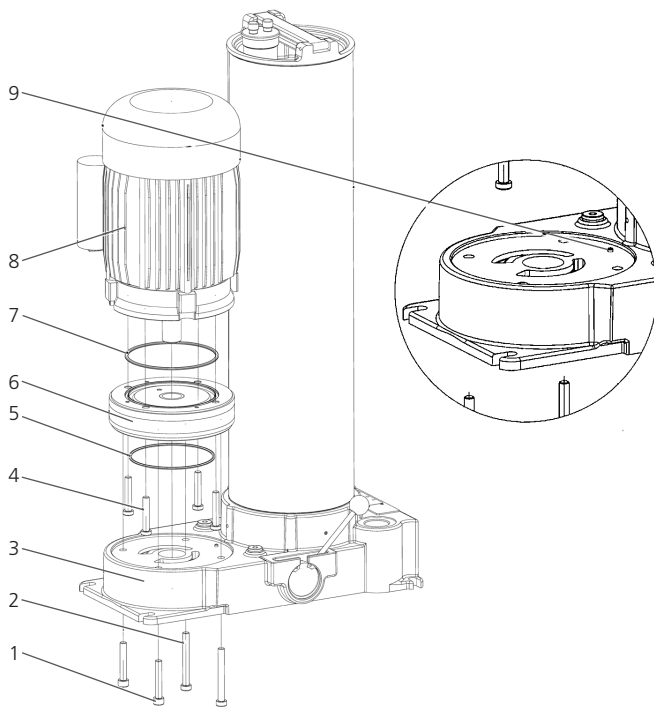

Fig. 8: Replacing the motor and the pump

#### 10.4.1 Removing the pump / motor

1. Unscrew the cylinder screws (Pos. 1 and 2) and release the motor / pump unit (Pos. 4 - 8) from the block (Pos. 3) in upward direction.
2. Unscrew the cylinder screws (Pos. 4) and release the motor (Pos. 8) from the pump (Pos. 7).

#### NOTE

- › When replacing the pump / motor, the O-rings (Pos. 5 and Pos. 7) must always be replaced by new O-rings. Please take the Order No. from the spare parts list.

#### 10.4.2 Installing the pump / motor

1. Lubricate the O-ring (Pos. 7) and insert it into the provided O-ring groove of the pump (Pos. 6).
2. Place the pump (Pos. 6) onto the motor (Pos. 8) and press it down. Make sure that the O-ring (Pos. 7) remains in the O-ring groove and that it is not damaged between the pump (Pos. 6) and the motor (Pos. 8).

#### NOTE

##### Observe the alignment of the pump

- › During the subsequent assembly, the suction and pressure kidneys of the pump (Pos. 6) must coincide with those of the pump block (Pos. 3) (ensure the correct position by a roll pin (Pos. 9)). Please also pay attention to the later position of the terminal box (Fig. 1 Pos. 4).

3. Fasten the pump (Pos. 6) using the cylinder screws (Pos. 4) ( $M_A 20^{+5} \text{ Nm}$ ).
4. Lubricate the O-ring (Pos. 5) and insert it into the provided O-ring groove of the pump (Pos. 6).
5. Fill the pump (Pos. 6) with oil via the suction and pressure kidneys and check the pump's operability (turn the shaft end of the motor once by  $360^\circ$  by hand).
6. Place the motor and pump assembly (Pos. 6 with Pos. 8) overhead on the pump block (Pos. 3). Make sure that the O-ring (Pos. 5) remains in the O-ring groove and that it is not damaged between the pump (Pos. 6) and the pump block (Pos. 3).
7. Fasten the motor / pump unit with the cylinder screws (Pos. 1 and Pos. 2) to the pump block (Pos. 3) ( $MA 20^{+5} \text{ Nm}$ ).
8. Fasten the filter pump block to the machine / system, using the rubber buffers (Order No. UM 045.0709) ( $M_A 20^{+5} \text{ Nm}$ ).
9. Connect the unit to the power supply according to the electrical connection diagram.

The device can be put into operation (see manual: Commissioning).

If no oil is sucked during commissioning, open the cover at the filter housing and fill in about 0.5 l oil.

## 10.5 Replacing the suction filter element / pump protection filter

### 10.5.1 Removing the suction filter element

- › Provide a drip tray for residual oil and the clogged filter element.
- › Unscrew the locking screw (Pos. 1) by a hexagon socket screw key AF 22.
- › Slightly pull the clogged element out of the housing.
- › Dispose of the filter element in line with environmental requirements, waste code: OILFILTER 16 0107

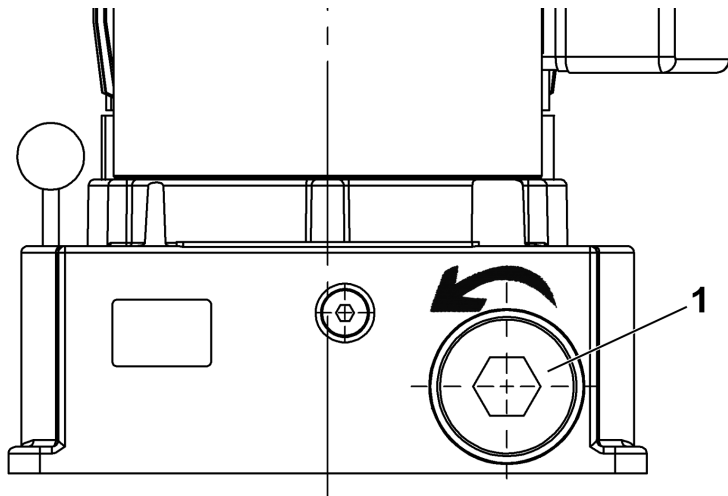

Fig. 9: Removing the suction filter element

### 10.5.2 Installing the suction filter element

- › Always replace the O-ring when changing the filter element.
- › Attach the suction filter element (Pos. 1) carefully into the pump block.
- › Screw in the locking screw and tighten it by a hexagon socket screw key AF 22 (MA 25  $\pm$ 2,5 Nm).
- › Check the tightness of the locking screw after starting operation and tighten it if necessary.

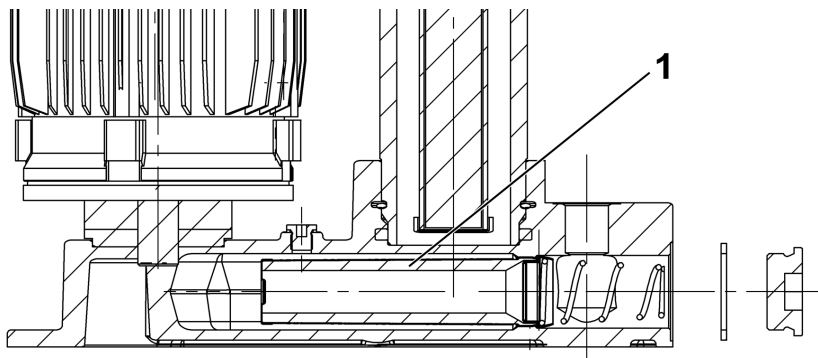

Fig. 10: Installing the suction filter element

#### NOTE

##### Suspected leakage

- › Oil which accidentally spilt onto the filter unit when changing the filter element may seem to be leaked oil. Review the facts.



**DANGER**



**Danger to life**  
**Risk of electric shock**

› Before uninstalling, pull the mains plug. Uninstalling may only be carried out by qualified electricians.



**Risk of injury**  
**Risk of injury by incorrect handling**

› Uninstalling may only be carried out by instructed persons.

The final decommissioning and disposal requires complete uninstallation of the total energy supply, the mechanical components and the disposal of the hydraulic media remaining in the device.

With disassembly and disposal, all national safety and environmental regulations must be observed.

The off-line filter unit is a device which does not have to be dismantled.

## 13. Disposal

---

- › Careless disposal of the off-line filter unit FNA 045 and the hydraulic fluid can lead to environmental pollution.
- › Therefore, dispose of the filter unit and the hydraulic fluid in accordance with the national regulations of your country.
- › Dispose of hydraulic fluid residues according to the applicable safety data sheets for these hydraulic fluids.



## 14. Troubleshooting

### 14.1 How to proceed

- › Get an overview on the function of the product in connection with the overall system.
- › Try to find out whether the product had provided the required function in the overall system before the error occurred.
- › Try to detect changes in the overall system, into which the product has been installed:
  - » Have the operating conditions or the operating range of the product changed?
  - » Have modifications (e.g. conversions) or repairs been carried out at the overall system (device / unit, electrics, control) or at the product? If so, which modifications?
  - » Has the product or the device been operated correctly?
  - » How does the fault tend to show?
- › Get a clear impression about the cause of trouble. Possibly consult the direct operator or machine operator.

### 14.2 Fault table

Problem / fault	Possible cause	Elimination
Electric motor does not turn on during commissioning	<ul style="list-style-type: none"> <li>› Electric cable or mains plug defective</li> <li>› Supply voltage missing</li> <li>› Motor defective</li> <li>› Pump defective</li> <li>› Viscosity too high (medium)</li> </ul>	<ul style="list-style-type: none"> <li>▶ Have the cable replaced by a skilled electrician</li> <li>▶ Establish the power supply or activate the electric fuse</li> <li>▶ Replace motor (repair at manufacturer's premises)</li> <li>▶ Replace pump (repair at manufacturer's premises)</li> <li>▶ Warm up the oil</li> </ul>
Electric motor switches off during operation	<ul style="list-style-type: none"> <li>› Electric motor overheated</li> <li>› Pump blocked</li> </ul>	<ul style="list-style-type: none"> <li>▶ Let the motor cool down, clean any contaminated ventilation slits</li> <li>▶ Replace pump (repair at manufacturer's premises)</li> </ul>
Volume flow is clearly too low	<ul style="list-style-type: none"> <li>› Filter element contaminated</li> <li>› Suction filter element contaminated</li> <li>› Viscosity too high</li> <li>› Suction height too large</li> <li>› Leak on suction side</li> <li>› Wear of the pump</li> </ul>	<ul style="list-style-type: none"> <li>▶ Replace filter element</li> <li>▶ Replace suction strainer</li> <li>▶ Warm up the medium</li> <li>▶ Adjust suction height</li> <li>▶ Replace suction hose or seal connection points (re-tighten them)</li> <li>▶ Replace pump (repair at manufacturer's premises)</li> </ul>
Operating noise too loud	<ul style="list-style-type: none"> <li>› Filter element contaminated</li> <li>› Suction filter element contaminated</li> <li>› Viscosity too high</li> <li>› Suction height too large</li> <li>› Leak on suction side</li> <li>› Wear of the pump</li> <li>› Off-line filter unit standing on a vibration-sensitive surface (e.g. sheet metal)</li> </ul>	<ul style="list-style-type: none"> <li>▶ Replace filter element</li> <li>▶ Replace suction strainer</li> <li>▶ Warm up the medium</li> <li>▶ Adjust suction height</li> <li>▶ Replace suction hose or seal connection points (re-tighten them)</li> <li>▶ Replace pump</li> <li>▶ Improve site conditions</li> </ul>
Pump does not suck	<ul style="list-style-type: none"> <li>› Leak on suction side</li> <li>› Sealing plug of the suction strainer is leaky</li> <li>› Unit pumped empty (with refilling)</li> </ul>	<ul style="list-style-type: none"> <li>▶ Replace suction hose or seal connection points (re-tighten them)</li> <li>▶ Check the sealing ring and replace it if necessary, check tightening torque</li> <li>▶ Prime the unit (0.3 l)</li> </ul>

Table 8: Fault table

## 15. Technical data

### 15.1 Device dimensions

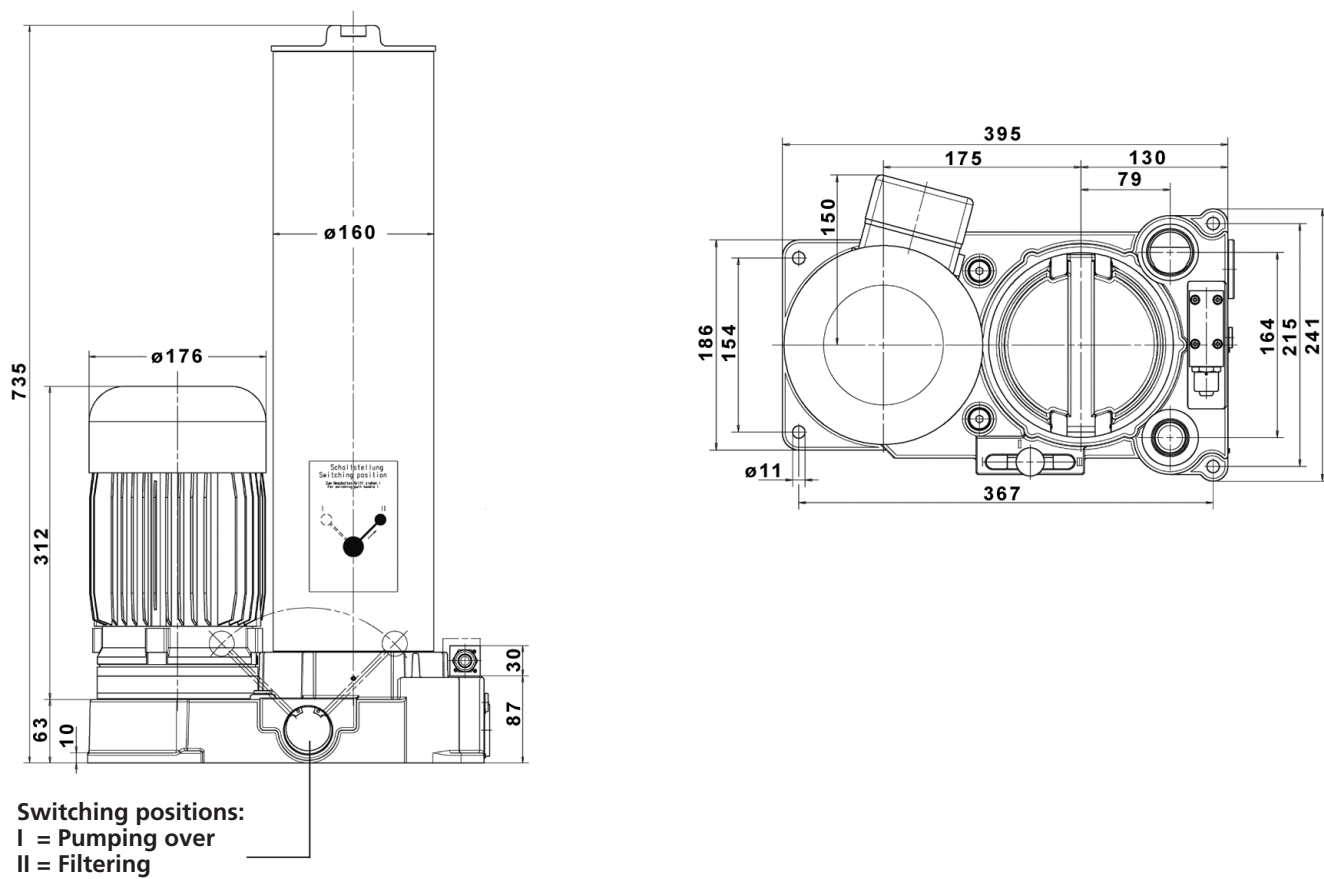

Fig. 11: Device dimensions

## 15.2 Technical data

Nominal flow rate (50 Hz)	l / m	45 (50 Hz) 54 (60 Hz)
Pressure limiting valve	bar	6 ± 0,5
Max. operating pressure	bar	7
Filter element		V7.1560-103 $\beta_{3(c)} \geq 200$ V7.1560-06 $\beta_{12(c)} \geq 200$ V7.1560-03 $\beta_{5(c)} \geq 200$ V7.1560-05 $\beta_{8(c)} \geq 200$ water absorption capacity approx. 1.5 l
Connection suction side		G 1 ¼" connection with hose DN 32 and suction pipe (when replacing the suction hose, only use a spiral hose)
Clogging indicator		re-fitting recommended
Connection pressure side		G 1" connection with hose DN 25 and pressure pipe
Suction strainer		strainer element 280 µm
Electric drive for device types FNA 045-1153 FNA 045-1553 FNA 045-1656		1~ AC-motor with operating capacitor 230 V / 50 Hz; 1.1 kW; n=1500 min <sup>-1</sup> , BG 90
Electric drive for device types FNA 045-4153 FNA 045-4553 FNA 045-4656		3~ AC motor 400 / 460 V - 50 / 60 Hz; 1.1 kW; n=1500 / 1800 min <sup>-1</sup> , BG 90
Tare weight	kg	approx. 36,8
Sound power level	db(A) max.	73 (under operating conditions permitted for continuous operation) 78 (under operating conditions permitted for short-term operation)
Device dimensions (length x width x height)	mm	see Chapter 15.1

Table 9: Technical data

### 15.3 Operating conditions

Permissible temperature range	Hydraulic fluid °C	0 ... 65 (note viscosity range)
	Ambient temperature °C	0 ... 50

#### ! CAUTION

	<p><b>Risk of burns</b>  <b>Contact temperatures according to DIN EN563 (3) and DIN EN13202 (4) may be exceeded during operation.</b></p> <p>› Allow the filter unit to cool down before touching it.</p>
---	---

Electric drive	Continuous operation min. [mm <sup>2</sup> /s]	Continuous operation max. [mm <sup>2</sup> /s]	Short-term operation [mm <sup>2</sup> /s]
1 ~ Motor, 230 V	15	600	800
3 ~ Motor, 400 V			

#### NOTE

#### Varying viscosity behavior

› Viscosities of a medium are always temperature-dependent.

Admissible suction heights	m (max.) first use / unfilled	2,0
	m (max.) operating status	6,0
Media resistance	Resistant to environmentally friendly and mineral oil based fluids. Before use with synthetic fluids please contact the manufacturer.	
Work position	standing	
Mains fuse		
FNA 045-1153 FNA 045-1553 FNA 045-1656	1 ~ Motor, 230 V / 50 Hz, 1.1 KW	
FNA 045-4153 FNA 045-4553 FNA 045-4656	3 ~ Motor, 400 V / 50 Hz, 1.1 KW	

### 15.4 Hydraulic circuit diagram

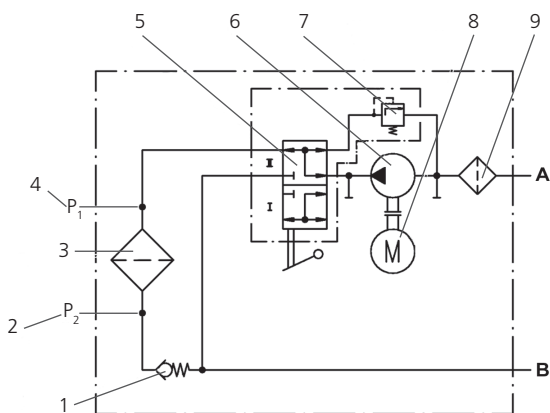

Fig. 12: Hydraulic circuit diagram

1	Check valve	4	P <sub>1</sub> : Pressure before filter element	7	Pressure limiting valve
2	P <sub>2</sub> : Pressure after filter element	5	Rotary directional control valve	8	Motor
3	Filter element	6	Pump clogging indicator	9	Suction filter element

## 15.5 Connection plan

 **DANGER**



**Danger to life**  
**Risk of electric shock**

› Electrical work on the off-line filter units has strictly to be carried out by qualified electricians.

Connections

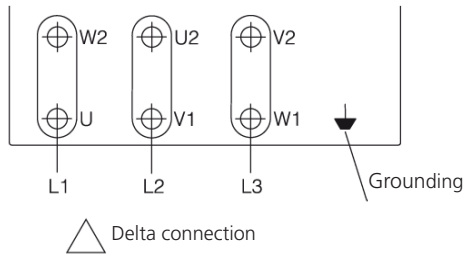

Connections

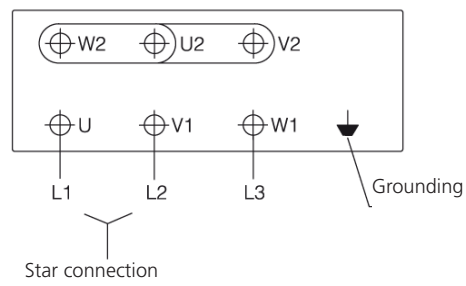

Connections

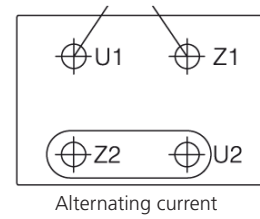

Fig. 13: Connection plan

16.1 Installation declaration

# Einbauerklärung

## Installation declaration



**ARGO-HYTOS Polska sp. z o.o.**  
Władysława Grabskiego 27  
32-640 Zator

Tel.: +48 33 873 16 52  
Fax: +48 33 873 19 15  
www.argo-hytos.com

Die Einbauerklärung gilt für folgendes Gerät:

The installation declaration applies to the following unit:

Nebenstromfilteraggregat

Off-line filter unit

### FNA 045

Wir bestätigen die Übereinstimmung mit den wesentlichen Anforderungen der europäischen Richtlinie(n):

We declare the conformity according to the essential requirements of the European directive(s):

**Maschinenrichtlinie 2006-42-EG**

**Machinery Directive 2006/42/EC**

**EMV Richtlinie 2004/108/EG**

**EMC Directive 2004/108/EC**

Folgende Norm(en) wurde(n) angewandt:

The following standard(s) was (were) applied:

**DIN EN 809**  
**DIN EN 60204-1 (VDE 0113-1: 2007-06)**

Zator, 22.11.2016

(Ort und Datum der Ausstellung)

(Place and date of issue)

A handwritten signature in blue ink that reads "A. Noworyta".

(Unterschrift ) Arkadiusz Noworyta/  
Vorsitzender des Vorstandes

(Signature) Arkadiusz Noworyta/  
President of the Board

## 16.2 Spare parts list

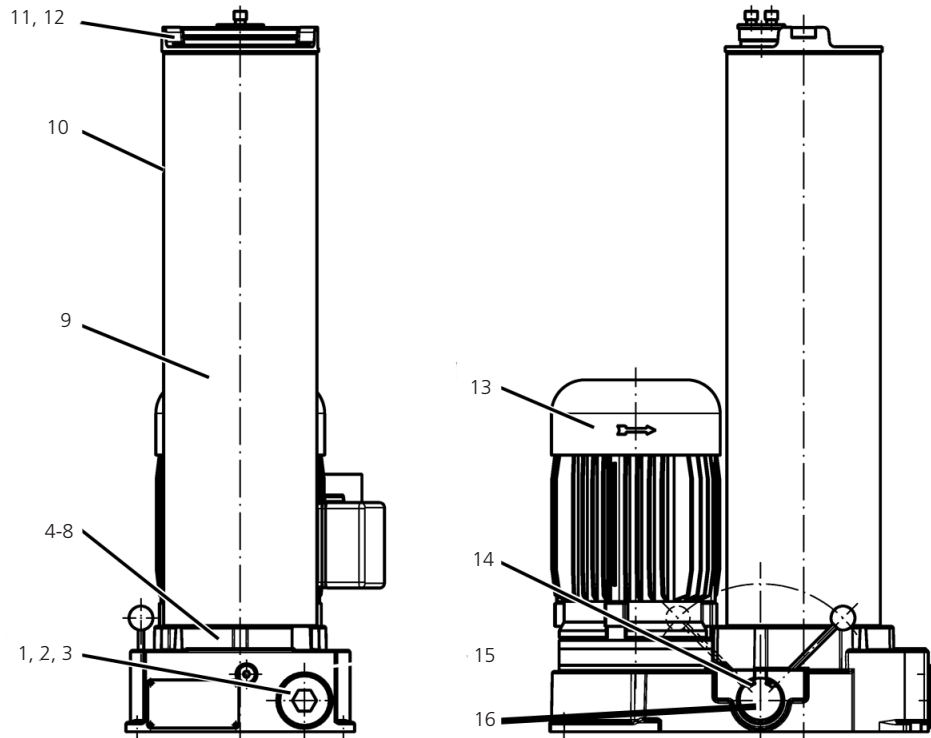

Fig. 14: Spare parts drawing

No.	Description	Pcs.	Part No.	Remark
1	Locking screw DIN 908-M45x2	1	13526600	
2	USIT-ring	1	17523000	
3	Screen element	1	S9.0417-13	
4	Pump	1	FNA 045.1900	
5	O-ring D112x3	1	N007. 1123	
6	O-ring D102x3	1	N007 .1023	
7	Cylinder screw ISO 4762-M8x50	4	13356000	
8	Cylinder screw ISO 4762-M8x50	4	13356000	
9	Filter element	1	V7.1560-03 V7.1560-103 V7.1560-06	
10	Housing	1	FNA 045.0103	
11	Cover, complete	1	FNA 045.1210	
12	O-ring	1	N007 .1455	
13	Motor		FNA 045.1760 FNA 045. 1770	1~Motor, 230V / 50 Hz, 1.1 KW 3~Motor, 400V / 50 Hz, 1.1 KW
14	Locking ring	1	FNA 045.0704	
15	Block	1	FNA 045.0104	
16	Pressure limiting valve	1	17008400	

Table 10: Spare parts list

International

## ARGO-HYTOS worldwide

<b>Benelux</b>	ARGO-HYTOS B.V.	info.benelux@argo-hytos.com
<b>Brazil</b>	ARGO-HYTOS Fluid Power Systems Ltda.	info.br@argo-hytos.com
<b>China</b>	ARGO-HYTOS Fluid Power Systems	info.cn@argo-hytos.com
<b>Czech Republic</b>	ARGO-HYTOS s.r.o ARGO-HYTOS Protech s.r.o	info.cz@argo-hytos.com info.protech@argo-hytos.com
<b>France</b>	ARGO-HYTOS SAS	info.fr@argo-hytos.com
<b>Germany</b>	ARGO-HYTOS GMBH	info.de@argo-hytos.com
<b>Great Britain</b>	ARGO-HYTOS Ltd.	info.uk@argo-hytos.com
<b>Hong Kong</b>	ARGO-HYTOS Hong Kong Ltd.	info.hk@argo-hytos.com
<b>India</b>	ARGO-HYTOS PVT. LTD.	info.in@argo-hytos.com
<b>Italy</b>	ARGO-HYTOS S.r.l.	info.it@argo-hytos.com
<b>Poland</b>	ARGO-HYTOS Polska spz o.o.	info.pl@argo-hytos.com
<b>Sweden</b>	ARGO-HYTOS Nordic AB	info.se@argo-hytos.com
<b>Turkey</b>	ARGO-HYTOS Hidrolik Ekip. San. ve Tic. Ltd. Şti.	info.tr@argo-hytos.com
<b>USA</b>	ARGO-HYTOS Inc.	info.us@argo-hytos.com

