

Off-line Filter Unit

FNA1HV



Safety and operating instructions

Read safety and operating instructions before use.

Note: The indicated data only serve to describe the product. Specifications regarding the use of this product are only examples and suggestions. Catalog specifications are no guaranteed features. The information given does not release the user from his / her own assessments and inspection.

Our products are subject to a process of natural wear and aging.

© All rights are reserved by ARGO-HYTOS GMBH, even in the event of industrial property rights. Any right of disposal such as copying and distribution rights shall remain with us.

The picture on the title page shows a configuration example. The delivered product may thus differ from the illustration.

Contents

Contents	2
1. About this documentation	4
1.1 Applicability of this documentation.....	4
1.2 Required and supplementary documentation.....	4
1.3 Presentation of information.....	4
2. Safety instructions	6
2.1 About this chapter.....	6
2.2 Intended use.....	6
2.3 Improper use.....	6
2.4 Reasonably foreseeable misuse.....	6
2.5 Qualification of personnel.....	6
2.6 General safety instructions.....	7
2.7 Product and technology-related safety instructions.....	7
3. General instructions	8
3.1 For prevention of material damage and product damage.....	8
4. Scope of delivery	9
5. About this product	10
5.1 Type plate.....	10
5.2 Component overview.....	11
6. Transport and storage	12
6.1 Transport.....	12
6.2 Storage.....	12
7. Installation	13
7.1 Mounting kit.....	13
7.2 Hydraulic connection.....	13
7.3 Mains connection.....	14
8. Installation recommendations	15
9. Operation of the off-line filter unit	16
9.1 Filtering liquids in the bypass flow.....	16
9.2 Ensuring maximum cleaning performance.....	16
10. Technical data	17
11. Operating conditions	19
12. Maintenance	20
12.1 Disassembly of the pump / motor.....	21
12.2 Installation of the pump / motor.....	22
12.3 Changing the filter element.....	23
13. Faultfinding / troubleshooting	26
14. Decommissioning / disposal	27

15. Annex	28
15.4 Hydraulic circuit diagrams.....	28
15.2 Connection diagrams	29
15.3 Spare parts lists	30
15.4 Installation declaration.....	32

1.1 Applicability of this documentation

This documentation is applicable for the following product series:

- › Off-line Filter Unit FNA1HV 005; FNA1HV 008; FNA1HV 016

This documentation is written for technicians, operators, service engineers and system operators.

This document contains important information for safe and appropriate assembly, transport, activation, operation, usage, servicing, dismantling and simple troubleshooting.

- › Read this document completely and in particular Chapter 2, "Safety instructions", before you work with the product.

1.2 Required and supplementary documentation

Do not commission the product until you have received the documentation marked with the book icon and before you have understood and complied with the information therein.

	Title	Number of document	1.2.1 Document type
	FNA1HV 008 / 016	80.41-EN/US · 0121	

Table 1: Required and supplementary documentation

1.3 Presentation of information

So that this document can help you to work quickly and safely with your product, we use standardized safety instructions, symbols, terms and abbreviations. For better understanding, these are explained in the following sections.

1.3.1 Safety instructions

In this documentation, safety instructions are faced with a sequence of actions which would result in the danger of personal injury or damage to equipment. The measures described to avoid these hazards must be observed.

 DANGER	
	<p>Type and source of danger</p> <ul style="list-style-type: none"> › Consequences of the danger › Escaping or averting the danger › Rescue (optional)

- › Warning signal: draws attention to the danger
- › Signal word: indicates the severity of the danger
- › Type and source of danger: specifies the type and source of danger
- › Consequences: describes the consequences in the event of non-compliance
- › Action: indicates how the danger can be avoided



Warning sign, signal word	Meaning
 DANGER	Indicates a dangerous situation which results in death or serious injury if not avoided.
 WARNING	Indicates a dangerous situation which may result in death or serious bodily injury if not avoided.
 CAUTION	Indicates a dangerous situation which may result in light to moderate injury if not avoided.
NOTE	Indicates property damage: The product or surrounding could be damaged.

Table 2: Meaning of the warning signs

1.3.2 Symbols

The following symbols indicate notes which are not safety-relevant but increase the intelligibility of the documentation.









Symbol	Meaning
	If this information is not observed, the product cannot optimally be used or operated
>	Singular, independent action step / instruction
1. 2. 3.	Numbered instruction The numbers indicate that the action steps follow one another
	This symbol indicates danger to equipment, material and environment
	This symbol indicates the risk of personal injury (minor injury).
	This symbol indicates the risk of personal injury (death, serious bodily injury).
	This symbol specifies that protective gloves should be worn.
	This symbol specifies that safety shoes should be worn.
	This symbol specifies that protective goggles should be worn.
	This symbol specifies that the unit should be disconnected from the power supply.
	This symbol indicates possible hazards to the environment.

Table 3: Meaning of symbols

1.3.3 Terms

In this documentation the following terms are used:

Term	Meaning
FNA1HV	Off-line Filter Unit

Table 4: Terms

1.3.4 Abbreviations

In this documentation the following abbreviations are used:

Term	Meaning

Table 5: Abbreviations

2.1 About this chapter

This product was manufactured according to the generally recognized standards of engineering. Nevertheless, there is a danger of injury or damage if you do not observe this chapter and the safety instructions in this documentation.

- › Read this document thoroughly and completely before working with the product.
- › Retain this document and ensure that it is available for all users at all times.
- › Always include the necessary documentation when passing the equipment along to a third party.

2.2 Intended use

This product is a hydraulic component.

You may use the product for the following:

- › for filtration of hydraulic fluids in the bypass flow on machines and systems, taking account of the technical data.
- › This product is intended for professional use only and not for private use.

"Intended use" also includes that you have completely read and understood this documentation, in particular Chapter 2 "Safety instructions".

2.3 Improper use

Any other use than the intended use described, is improper and inadmissible.

If unsuitable products are installed or used in safety-related applications, unintended operating states may occur in the application, which may cause personal injury and / or property damage.

Therefore only use this product in safety-related applications if this use is explicitly specified and permitted in the product documentation, e.g. in explosion protection areas or in safety-related parts of a control system (functional safety).

The ARGO-HYTOS GMBH assumes no liability for damages resulting from improper use. The risks associated with improper use are solely with the user.

2.4 Reasonably foreseeable misuse

The delivery of the following media is forbidden:

- › others than listed in Chapter 16 "Technical data".

Especially

- › flammable liquids such as petrol or thinner (explosion hazard)
- › foodstuffs
- › The device is not suitable for sucking sludge and sediment.

The operator alone is liable for damages resulting from improper use.

2.5 Qualification of personnel

The operations described in this document require fundamental knowledge of mechanics and hydraulics as well as knowledge of the appropriate technical terms. In order to ensure safe use, these operations may therefore only be carried out by a correspondingly skilled worker or an instructed person under the guidance of a skilled worker.





A skilled worker is someone who can - based on his / her technical education, knowledge and experience as well as knowledge of the respective regulations of the jobs assigned to him / her - recognize possible dangers and ensure appropriate safety measures.

A skilled worker must observe the relevant technical regulations.

2.6 General safety instructions

- › Observe the valid regulations for accident prevention and environmental protection.
- › Observe the safety regulations and requirements of the country in which the product is used / applied.
- › Only use ARGO-HYTOS products that are in technically perfect condition.
- › Observe all instructions on the product.
- › People who assemble, operate, disassemble or maintain ARGO-HYTOS products may not do so under the influence of alcohol, other drugs or medications that affect the responsiveness.
- › Only use manufacturer-approved accessories and spare parts, in order to prevent personal danger due to unsuitable spare parts.
- › Observe the technical data and ambient specifications specified in the product documentation.
- › If unsuitable products are used or installed in safety-relevant applications, unintended operating states may occur in the application, which can cause personal injury and / or material damage. Therefore only use the product in safety-relevant applications if this use is explicitly specified and permitted in the product documentation.
- › You may only put the product into operation, when it has been established that the final product (e.g. a machine or system), into which the ARGO-HYTOS products have been installed, complies with the country-specific regulations, safety regulations and standards of the application.

2.7 Product and technology related safety instructions

 CAUTION	
	<p>Leaked hydraulic oil Environmental hazard / risk of slipping.</p> <ul style="list-style-type: none">› In case of spills, cover the oil-covered surface immediately with an oil-binding medium.› Then immediately dispose of the oil-binding medium according to the national environmental regulations.
	<p>Ignition hazard Risk of electrostatic charge by poorly conducting hydraulic fluid.</p> <ul style="list-style-type: none">› If the electrical conductivity of the hydraulic fluid is not known, please contact the manufacturer of the hydraulic fluid.
	<p>Risk of burns Contact temperatures according to DIN EN563 (3) and DIN EN13202 (4) may be exceeded during operation.</p> <ul style="list-style-type: none">› Allow the off-line filter unit to cool down before touching it.

3.1 For prevention of material damage and product damage



CAUTION

**Danger due to improper handling****Property damage**

- › The off-line filter unit FNA1HV 005; FNA1HV 008; FNA1HV 016 may only be used in accordance with Section 2.2, "Intended use".

Leakage or spillage of hydraulic fluid**Environmental pollution and ground water contamination.**

- › Use oil binding agents in order to bind leaked hydraulic oil.

**Risk of burns****Contact temperatures according to DIN EN563 (3) and DIN EN13202 (4) may be exceeded during operation.**

- › Allow the off-line filter unit to cool down before touching it.

Contamination due to fluids and foreign bodies**Premature wear, malfunction, risk of damage, property damage.**

- › Ensure cleanliness during installation in order to prevent foreign bodies, such as welding beads or metal chips, from entering the hydraulic lines, leading to premature wear or malfunction.
- › Make sure that connections, hydraulic lines and attachment parts (e.g. gauges) are free from dirt and chips.
- › Prior to commissioning, check that all hydraulic and mechanical connections are connected and tight, and that all gaskets and seals of the plug connectors are correctly assembled and undamaged.
- › For removal of lubricants and other contaminants, use residue-free industrial wipes.
- › Make sure that all connections, hydraulic lines and attachment parts are clean.
- › Ensure that no contaminants enter when closing the connections.
- › Make sure that no detergents enter the hydraulic system.
- › Do not use cotton waste or faying cleaning rags for cleaning.
- › Do not use hemp as sealing agent.

**Improper cleaning****Premature wear, malfunction, risk of damage, property damage.**

- › Close all openings with appropriate protective fittings to prevent penetration of detergents.
- › Do not use aggressive cleaning agents for cleaning. Clean the product with a suitable cleaning fluid.
- › Do not use a high pressure cleaner.
- › Do not use compressed air to clean function interfaces such as seal areas.

The package includes:

- › 1 Off-line Filter Unit FNA1HV 005 / FNA1HV 008 / FNA1HV 016
- › 1 Operating manual
- › Mounting kit (rubber buffers, washers, nuts)

The off-line filter unit "FNA1HV 005 / FNA1HV 008 /FNA1HV 016" is a filter system for filtering hydraulic fluids in the bypass flow.

5.1 Type plate

NOTE



Type plates are documents; they must not be modified or removed.

› Damaged or lost type plates must be replaced with exact copies of the original.

PL 32-640 Zator
www.argo-hytos.com
Made in EU

ARGO
HYTOS

T7

Type: FA 016-1300
Filter element: V7.1220-13
Filter fineness: 5 µm
Q nom = 16 l/min
P max = 4 bar
Serial number: 2015-02/428930-03

Fig. 1: Type plate (example)

5.2 Component overview



Fig. 2: Component overview

- | | |
|---|-------------------|
| 1 Filter cover | 5 Oil inlet port |
| 2 Filter housing | 6 Motor-pump unit |
| 3 Filter element | 7 Cable entries |
| 4 Connection clogging indicator /
clogging indicator | 8 Oil outlet port |

This chapter contains information on the transport, setting up, connecting and putting into operation as well as storage of the unit.

NOTE



To be observed:

- › The safety instructions in chapter "Safety information" and here particularly the operating conditions in section "Intended use".
- › Dimensions and weight of the unit in chapter "Technical data".

6.1 Transport

- › The unit is not suitable for transport

6.2 Storage

6.2.1 Preparation for storage

- › The unit must be completely emptied.
- › Treat all bare parts with preservatives.

6.2.2 Storage

- › Do not store the unit near flammable liquids or gases.
- › Do not store in the rain or in damp and wet environment.

7 Installation

7.1 Mounting kit

The unit must be fixed sufficiently safe and vibration-free by using the provided mounting kit (tightening torque of the hexagon nuts (3): $M_A 5^{+2} \text{ Nm} - \text{AF } 10$).

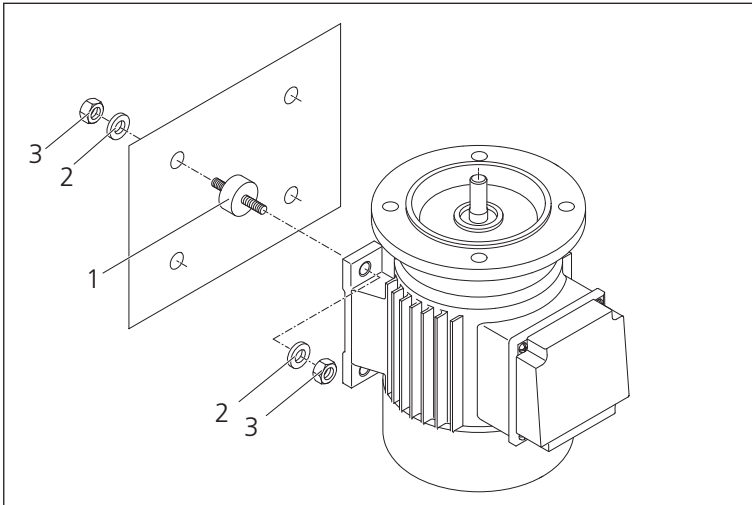

Fig. 3: Mounting kit

- | | |
|------------------------|-------------------------|
| 1 Damping element (4x) | 3 Hexagon nut AF10 (8x) |
| 2 Washer (8x) | |



7.2 Hydraulik connection

CAUTION



Risk of malfunctions!

- › When hydraulically connecting the off-line filter unit, a strainer must be used on the suction side.
- › A missing suction strainer can lead to destruction of the pump. In this case, the manufacturer assumes no liability.
- › With installation of the off-line filter units, a clogging indicator must be used.
- › Without a clogging indicator, element contamination is not detectable.

 DANGER	
	<p>Danger to life through electric shock!</p> <ul style="list-style-type: none"> › Electrical work may only be carried out by qualified electricians. › The mains voltage must match the voltage indicated on the type plate (motor). › The direction of rotation of the motor must match the direction of rotation arrow on the motor housing. › Check the direction of rotation of the motor each time the unit is switched on (only for three-phase motor). › The power source must be sufficiently fused (see page 23). › Cable cross-sections must be sufficiently dimensioned. › Cables and connection to the power source must be in perfect condition.

Always observe before operating the filter unit:

- › The above-mentioned operating conditions (see page 19) must be strictly observed.
 - › Read the installation instructions carefully and completely.
 - › Cables and hoses must not be laid within the operating personnel's range of movement (risk of tripping).
 - › During unattended operation, make sure that hoses cannot fall out of the tank.
 - › Ensure that the suction and pressure sides are sufficiently immersed in hydraulic fluid (sucking in air can lead to malfunctions).
 - › If no air is sucked in during commissioning, open the cover on the filter housing and fill in approx. 0.3 l of oil.
 - › The oil must be compatible with the operating fluid from the previous filtrations. If this is not the case, the filter system must be cleaned and the filter element must be replaced.
-
- › The cover of the filter housing must be properly closed. If necessary, turn the cover by hand as far as it will go; there may be a gap that remains visible between the cover and the housing (see fig. 4)

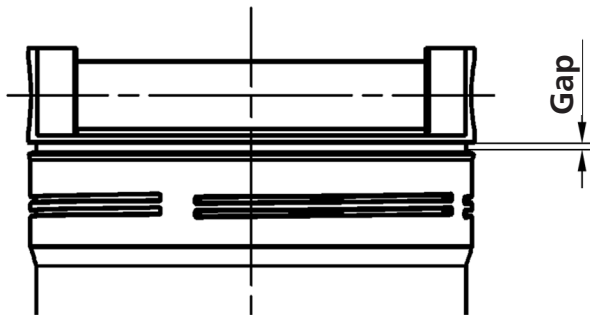

Fig. 4: Gap between cover and housing

On start-up please check:

- › Tightness of the filter unit.
- › For 3-phase AC motors, check whether the motor's direction of rotation corresponds to the direction of rotation arrow on the motor housing. If not, only allow qualified personnel to invert the phases (only with 3-phase motor).

In the event of power failure

- › Switch the unit off or disconnect it from the mains to avoid consequential damage to people and the environment when the voltage returns, e.g. due to overflowing oil or danger of slipping due to leaking oil.



CAUTION

**Risk of malfunctions!**

- › When connecting the off-line filter unit hydraulically, a strainer must be inserted on the suction side.
- › A missing strainer can lead to the destruction of the pump. In this case, the manufacturer assumes no liability.
- › When installing the off-line filter units, a contamination indicator must be used.
- › Without a clogging indicator, element clogging cannot be detected.

Device type	FNA1HV 005; FNA1HV 008; FNA1HV 016
Installation position	Vertical
Fixing	Mounting only by using the supplied mounting kit ($M_A 5^{+2}$ Nm)
Clearance filter element	min. 340 mm
Recommended connection for piping	All cutting and progressive ring fittings of the series L or LL from Parker (ERMETO Original) EO-standard program according to DIN 2353/ISO 8434-1
Recommended connection for hoses suction connection - \varnothing (inlet)	min. DN 32 and max. -0,4 bar negative pressure
Recommended connection for hoses pressure connection - \varnothing (outlet)	min. DN 25
Suction height	max. 1.5 m
Pump protection	Min. fineness 600 μ m e. g. order no. FA 016.0303
Max. cleaning performance	Keep the distance between suction and pressure side as large as possible (no short-circuit of oil flow)

Table 6: Installation recommendations

**CAUTION****Risk of malfunctions!**

- › When connecting the off-line filter unit hydraulically, a strainer must be inserted on the suction side.
- › A missing strainer can lead to the destruction of the pump. In this case, the manufacturer assumes no liability.
- › When installing the off-line filter units, a contamination indicator must be used.
- › Without a clogging indicator, element clogging cannot be detected.

9.1 Filtering hydraulic fluids in the bypass flow.

- › Attach the filter unit as described under point 7 and connect it (with 3~ motors observe direction of rotation).
- › When using a suction bell or a suction and pressure lance resp., immerse these into the hydraulic tank of the machine or system.
- › Depending on the connection, the filter unit can be switched on automatically (with the machine or system) or manually.
- › Control of the oil flow (sufficient immersion depth of the strainer or the suction lance resp. into the hydraulic fluid).
- › Check the element for clogging, using the clogging indicator.

NOTE

- › At the beginning of filtration, it may take a few seconds to fill the filter unit.
- › To prevent an oil flow short circuit, the distance between the suction bell or the suction and pressure lances should be kept as large as possible.

9.2 Ensuring maximum cleaning performance

- › Start up hydraulic or lubrication system (circulation of fluid, lower viscosity).
- › Keep the distance between the suction and pressure sides as large as possible (no short-circuiting of the oil flow).
- › Keep an adequate filtration time - recommended guideline values:
 - 90 minutes per 100 l / 26.4 gal tank capacity with FNA1HV 005 devices
 - 60 minutes per 100 l / 26.4 gal tank capacity with FNA1HV 008 devices
 - 30 minutes per 100 l / 26.4 gal tank capacity with FNA1HV 016 devices

NOTE



› For device-specific technical data, please see table 8, page 19.

	FNA1HV 005	FNA1HV 008	FNA1HV 016
Nominal flow rate	5 l/min (50 Hz) or 6 l/min (60 Hz)	8 l/min (50 Hz) or 9.5 l/min (60 Hz)	16 l/min (50 Hz) or 19 l/min (60 Hz)
Pressure relief valve	5 ± 0.5 bar		
Filter element	see page 18		
Clogging indicator	on request, see page 18		
Connections	see page 15 - table 6		
Suction strainer (optional)	fineness 600 µm		
Electric drives	see page 18		
FNA1HV 005 / 40050	3~ three-phase motor, 400/460 V, 50/60 Hz, 0.37/0.44 kW; n = 860/1030 min ⁻¹		
FNA1HV 008 / 23050	1~ AC motor with operating capacitor, 220-240 V, 50/60 Hz, 0.37 kW; n = 1500/1800 min ⁻¹		
FNA1HV 008 / 40050	3~ three-phase motor, 400/460 V, 50/60 Hz, 0.37/ 0.44 kW; n = 1500/1800 min ⁻¹		
FNA1HV 016 / 23050	1~ AC motor with operating capacitor, 220-240 V, 50/60 Hz, 0.55 kW/0.66 kW; n = 3000/3600 min ⁻¹		
FNA1HV 016 / 40050	3~ three-phase motor, 400/ 460 V, 50/ 60 Hz, 0.55/ 0.66 kW; n = 3000/ 3600 min ⁻¹		
Weight when empty	approx. 11 kg		
Noise intensity level	max. 73 dB(A) under operating conditions allowed for continuous operation max. 79 dB(A) under operating conditions allowed for short-term operation		

Table 7 : Technical data

FNA1HV

- / -

Type of filter unit	Code
Off-line filter unit, high viscosity version	FNA1HV

Nominal flow rate*	Code
5 l/min / 1.32 gpm	005
8 l/min / 2.11 gpm	008
16 l/min / 4.23 gpm	016

Connection ports	Code
In: G1 Out: G ³ / ₄	G
In: 1 ⁵ / ₁₆ -12 UN-2B Out: 1 ¹ / ₁₆ -12 UN-2B	U

Filter element						Code
		Fineness (β=200) Dirt-holding capacity according to ISO 16889 / water capacity			Spare filter element code	
		FNAHV1 005	FNAHV1 008	FNAHV1 016		
EXAPOR [®] MAX 2	3 μm	490 g	280 g	160 g	V7.1220-113	V003
EXAPOR [®] MAX 2	5 μm	460 g	270 g	140 g	V7.1220-13	V005
EXAPOR [®] MAX 2	10 μm	340 g	190 g	110 g	V7.1220-06	V010
EXAPOR [®] AQUA	7 μm	64 g / 320 ml	38 g / 190 ml	22 g / 110 ml	Y7.1220-05	Y007
EXAPOR [®] AQUA	3 μm	45 g / 340 ml	25 g / 205 ml	15 g / 120 ml	Y7.1220-113	Y003

Electric motor*				Code
Phase(s), voltage	Frequency	Power FNA1HV 005 / 008 / 016	Elec. connection	
3~400/460 VAC	50/60 Hz	0.37 / 0.37 / 0.55 kW	1	40050
1~230 VAC	50/60 Hz	0.37 / 0.37 / 0.55 kW	2	23050

Clogging indicator						Code
Type		Code of indicator	Connection	Datasheet number	Hydraulic symbol	
Differential pressure clogging indicator	optical	DG 042-05	Flange	60.30	1	OD
	electrical	DG 041-32	Flange	60.30	2	ED
	electrical + optical	DG 041-32 DG 041.1200	Flange	60.30	3	EOD
Without clogging indicator					4	XD

* Indications at 50 Hz. At 60 Hz, the value increases by approx. 20%.

11 Operating conditions

Permissible temperature range	Hydraulic fluid: 0 °C to 60° C / 32 °F to 140 °F Environment: 0 °C to 50° C / 32 °F to 122 °F			
Permissible viscosity range	Type of unit	Continuous operation min.	Continuous operation max.	Short-term operation max.
	FNA1HV 005	15 mm ² /s	3500 mm ² /s	4500 mm ² /s
	FNA1HV 008	15 mm ² /s	2500 mm ² /s	3500 mm ² /s
	FNA1HV 016	15 mm ² /s	1500 mm ² /s	2000 mm ² /s
Permissible suction heights	max. 1 m (unfilled) max. 6 m (in operating condition)			
Media resistance	Resistant to environmentally friendly and mineral oil based fluids. In case of synthetic fluids, please consult the manufacturer.			
Mains fuse	230 V, 50/60 Hz	10 A – 16 A		
	400/460 V, 50/60 Hz	10 A – 16 A		
Working position	upright			

Table 8: Operating conditions

! DANGER**Danger to life through electric shock!**

- › Disconnect the device from the power supply during maintenance work.
- › Electrical work may only be carried out by qualified electricians.

! WARNING**Hot surfaces - danger of burns!**

- › Let the filter unit cool down and empty it completely before maintenance.

! WARNING

- › When replacing the pump / motor, proceed with special care.
- › All parts coming into contact with the hydraulic medium must be kept free of dirt and chips.
- › If dirt enters the pump during maintenance work, optimal functioning of the device is no longer guaranteed. In this case, the manufacturer assumes no liability!

NOTE**When performing any work:**

- › Wear protective gloves, safety shoes and safety goggles!

12.1 Disassembly of the pump / motor

When replacing the pump / motor, proceed with the following steps:

1. Loosen the hexagon nuts (8) and washers (7).
2. Lift the module "filter pipe and housing" (2) upwards.
3. Remove the pump plate (5) together with the wheel set (5.1) from the motor (9) and lift them upwards.
4. Detach the motor (9) from the brackets.
5. Dispose of old parts in an environmentally compatible way.

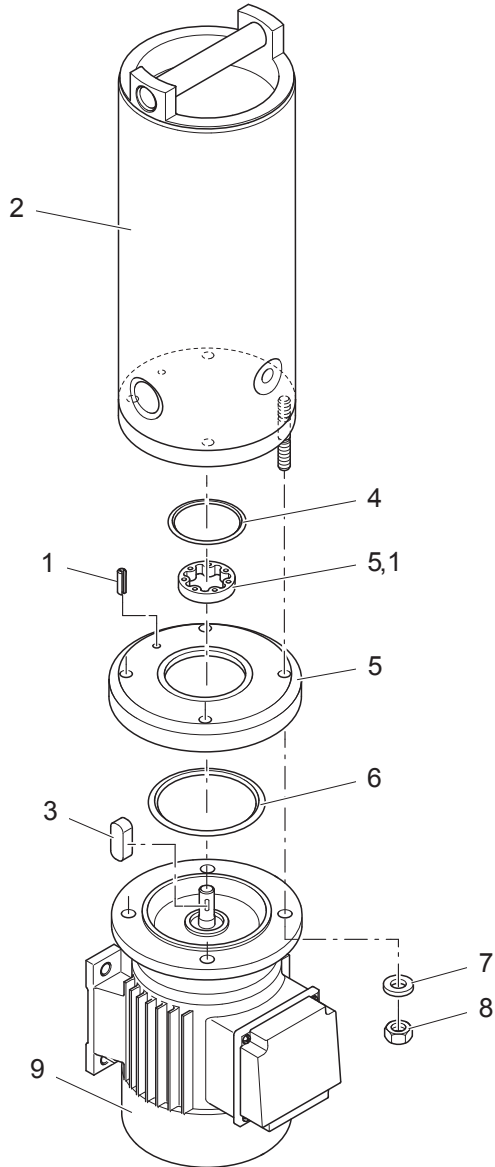

Fig. 5: Exploded view of the off-line filter unit

12.2 Installation of the pump / motor



- › Always replace the O-rings (4, 6, fig. 5) by new spare parts when changing the pump / motor. (Order-no. see spare parts list from page 30 on).

1. Attach the motor (9) to the corresponding brackets (see assembly kit page 13).
2. Insert outer and inner rotor (5.1) into the corresponding section of the pump plate (5) (in any position).
3. Oil the O-rings (4, 6) and insert them into the provided O-ring grooves of the pump plate.
4. Fit the pre-assembled pump plate (5, 5.1, 4, 6) onto the motor (9).
5. Insert the key (3) of the motor shaft into one of the four key grooves of the inner rotor.
6. During assembly, make sure that the O-ring (6) is seated in the O-ring groove and is not squeezed between the motor and the pump plate.
7. The hole for the roll pin (1) must be opposite the terminal box on the motor.
8. Fill the wheel sets with clean oil and check the smooth running of the pump. To do this, turn the shaft end of the motor once by hand through 360°.
9. Reassemble the "filter tube with housing" module (2) with the pump plate and the motor.
10. When mounting the filter tube, make sure that the O-ring (4) is seated in the O-ring groove and is not squeezed between the pump plate (5) and the housing (2).
11. Mount hexagons nuts (8) with washers (7) ($M_A 15^{+2}$ Nm).

The device can be put back into operation (see operating instructions: Commissioning). If no oil is sucked in during commissioning, open the cover at the filter housing and fill in about 0.3 l oil.

If the electrical supply has been removed from the motor, connect it in accordance with the electrical circuit diagrams.

12.3 Changing the filter element

The off-line filter unit is maintenance-free, except from the filter element (see page 11, pos. 3) and the suction strainer (if used).

Maintenance work	Order no.	Maintenance interval
Check / change filter element	V7.1220-113 (3 µm) V7.1220-13 (5 µm) V7.1220-06 (10 µm) Y7.1220-05 (7 µm) Y7.1220-113 (3 µm)	Once the contamination indicator changes to the red area within the range of permissible viscosity.
Check / change suction strainer	FA 016.0301	a) Visual inspection before each commissioning. b) On each change of the filter element.

Table 9: Maintenance intervals

It is necessary to change the filter element if - during operation in the range of the permissible viscosity - the clogging indicator changes from the green to the red area.

Follow the steps below to change the filter element (see also Fig. 5 and Fig. 6):

12.3.1 Before changing the filter element

1. When using a suction strainer or suction lance, remove the corresponding component from the hydraulic tank of the machine or system and suck air for max. 30 seconds. Residual oil from the bypass filter unit is returned to the hydraulic tank of the machine or system via the pressure lance.
2. Switch off the unit and disconnect the power supply.
3. If necessary, let the unit cool down.

12.3.2 Disassembly of the filter element

4. Unscrew the filter cover.
5. Carefully pull the cover with the filter element out of the housing.
6. (Filter element is attached to the cover, let escaping oil drip down into the housing).
7. Release the filter element from the cover by moving it as shown in Fig. 6.
8. Dispose of the filter element in accordance with environmental regulations, waste code: OIL FILTER 16 01 07

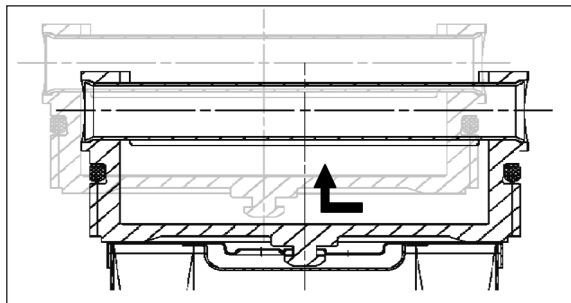

Fig. 6: Releasing the fixture at the cover / filter element

12.3.3 Installation of the filter element

1. When changing the filter element, always replace the O-ring in the cover (part of the delivery).
2. Check the type number of the filter element:
3. (compare the numbers of the laser inscription on the filter element and the type plate).
4. Attach the filter element to the cover (see Fig. 7).
5. Carefully insert the cover with the filter element into the filter housing.
6. Screw the cover in manually until it stops. A gap may remain visible between the cover and the housing (see Fig. 4, page 14).
7. Check that the ventilation slots of the electric motor are clean, remove any contamination.
8. Restart the unit.
9. After commissioning, check the tightness of the filter housing.

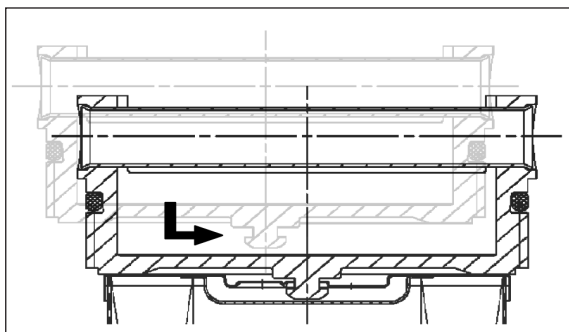

Fig. 7: Attaching the cover to the filter element

NOTE



- › Oil that has accidentally drained onto components of the off-line filter unit when changing the filter element, could be considered as leakage oil.

12.3.4 Checking / changing the suction strainer FA 016.0303

The suction strainer should be checked - and if necessary changed - every three months or with anomalies (significantly lower volume flow with a clean filter element, too loud operating noise).
When changing the suction strainer proceed as follows (see fig. 8):

1. Release the hose clamp (1) and pull the suction strainer (3) from the suction hose (2).
2. Clean the suction strainer (3) with cleaning solvent or diesel fuel or replace it if damaged (Order No. FA 016.0303) and dispose of the used part in accordance with the environmental requirements, waste code: OIL FILTER 16 01 07.
3. Attach the suction strainer (3) to the suction hose (2) according to Fig. 8 and secure it with the hose clamp (1).

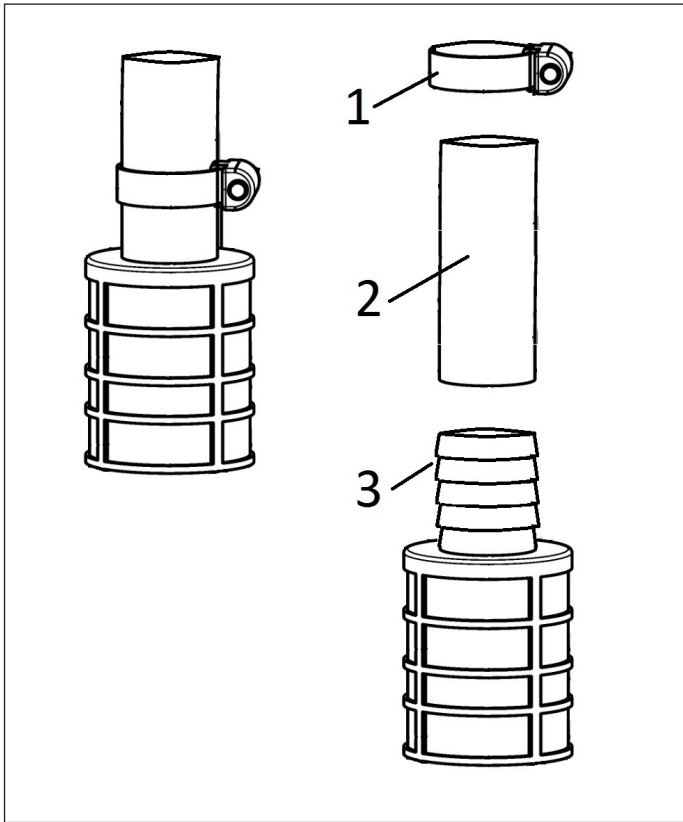

Fig. 8: Suction strainer FA 016.0303

Position	Designation	Order number
1	Hose clamp	DIN 03017
2	Suction strainer	FA 016.0303

Table 10: Spare parts suction strainer FA 016.0303

Problem / fault	Possible cause	Elimination
E- Motor cannot be switched on during commissioning	<ul style="list-style-type: none"> › E-cable or connector are defective › Missing mains voltage › Motor / pump are defective › Too high viscosity 	<ul style="list-style-type: none"> › Have cable replaced by a specialist › Provide mains voltage or activate electric fuse › Replace motor / pump (repair at manufacturer's premises) › Heat medium
Electric motor switches off during operation	<ul style="list-style-type: none"> › E-motor is overheated › Pump is blocked 	<ul style="list-style-type: none"> › Allow engine to cool down, clean ventilation slits if necessary › Replace pump (repair at manufacturer's premises)
Flow rate is significantly too low	<ul style="list-style-type: none"> › Filter element is clogged › Suction strainer is clogged › Viscosity is too high › Suction height is too great › Leak on suction side › Pump is worn 	<ul style="list-style-type: none"> › Replace filter element › Replace suction strainer › Heat medium › Adjust suction height › Replace suction hose or seal the connection points (tighten them) › Replace pump (repair at manufacturer's premises)
Too loud operating noise	<ul style="list-style-type: none"> › Filter element is clogged › Suction strainer is clogged › Viscosity is too high › Suction height is too great › Leak on suction side › Filter unit is mounted on a vibration-sensitive surface (e.g. metal sheet) 	<ul style="list-style-type: none"> › Replace filter element › Replace suction strainer › Heat medium › Adjust suction height › Replace suction hose or seal the connection points (tighten them) › Improve local conditions
Pump does not suck in fluid	<ul style="list-style-type: none"> › Leak on suction side › Filter unit is running dry (with new filling) 	<ul style="list-style-type: none"> › Replace suction hose or seal connection points (tighten them) › Pre-fill the unit (0,3 l to 3 l)
Oil on fan cover	<ul style="list-style-type: none"> › Sealing ring is leaking 	<ul style="list-style-type: none"> › Replace motor or have it repaired at manufacturer's premises
Oil is running out of the terminal box	<ul style="list-style-type: none"> › Residual oil at housing after filter element change › Screw connection is leaking 	<ul style="list-style-type: none"> › Clean off-line filter unit › Check screw connections, tighten / seal them if necessary



Table 11: Fault table

The final decommissioning and disposal requires the complete uninstallation of the entire power supply, the mechanical components and the disposal of the hydraulic media remaining in the unit. All safety and environmental aspects must be taken into account when dismantling and disposing of the residual hydraulic media.

NOTE

	<p>Hazards to the environment!</p> <ul style="list-style-type: none"> › When disposing of the device, observe the applicable national and regional regulations and instructions of the manufacturer. › Separate operating and auxiliary materials by type and dispose of them properly.
---	--

! DANGER

 	<p>Danger to life through electric shock!</p> <ul style="list-style-type: none"> › Interrupt power supply during uninstallation. › Uninstallation of electrical components may only be carried out by qualified electricians.
--	--

! WARNING

	<ul style="list-style-type: none"> › Uninstallation of the filter and pumping-over unit may only be carried out by qualified electricians. › Risk of injury of any kind.
---	--

15.1 Hydraulic circuit diagrams (also see page 18)



WARNING



- › No changes must be made to the device.
- › The hydraulic circuit diagram is only to be used for maintenance and repair works of off-line filter units.

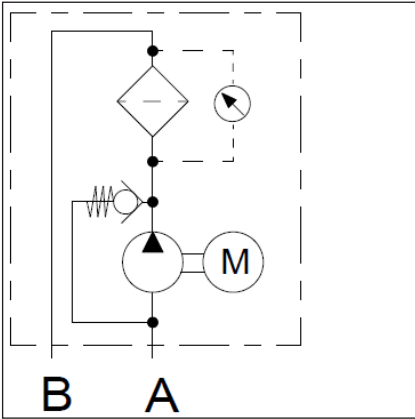

Type 1 (code OD)

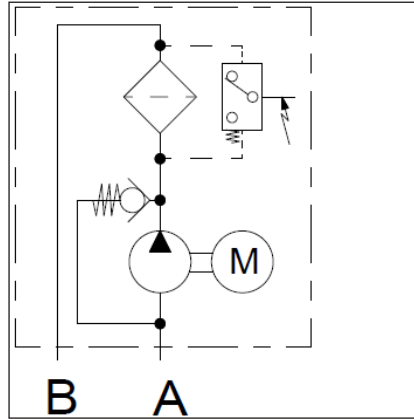

Type 2 (code ED)

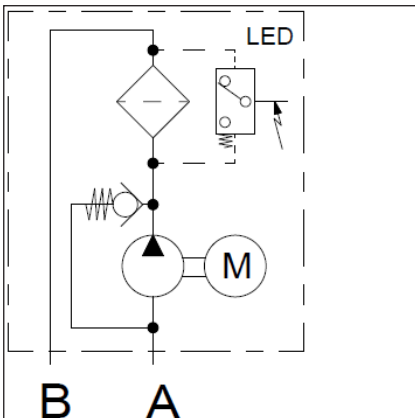

Type 3 (code EOD)

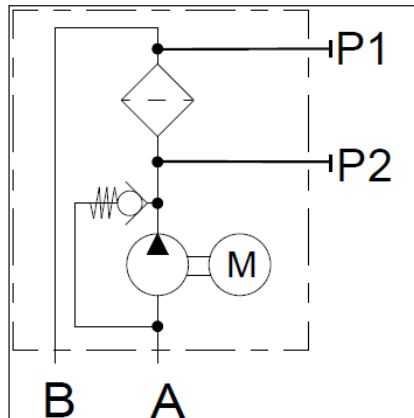

Type 4 (code XD)



Danger to life through electric shock!

› Electrical connection of the off-line filter units may only be carried out by qualified electricians.

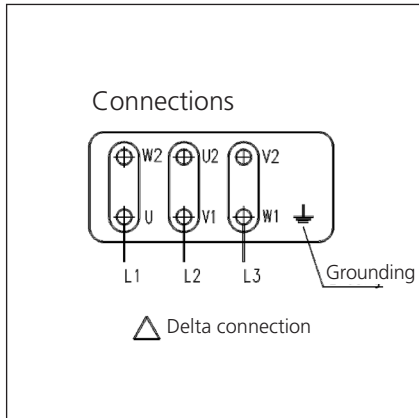

Type1 3~ delta connection

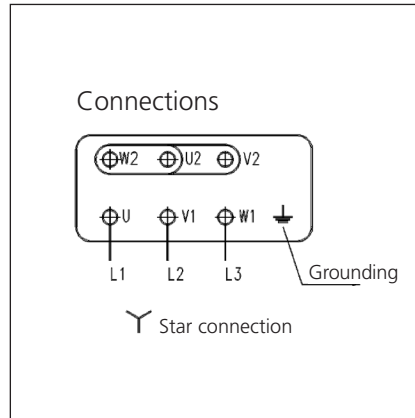

Type 1 3~ star connection

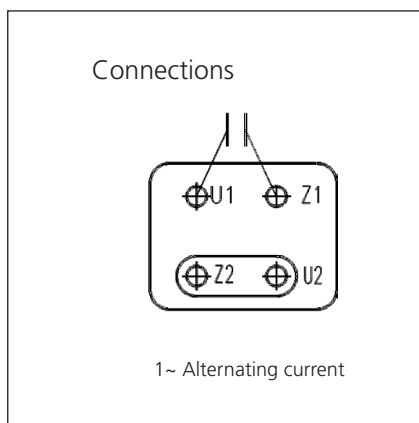

Type 2 1~ alternating current

15.3 Spare parts list

15.3.1 Spare parts drawing

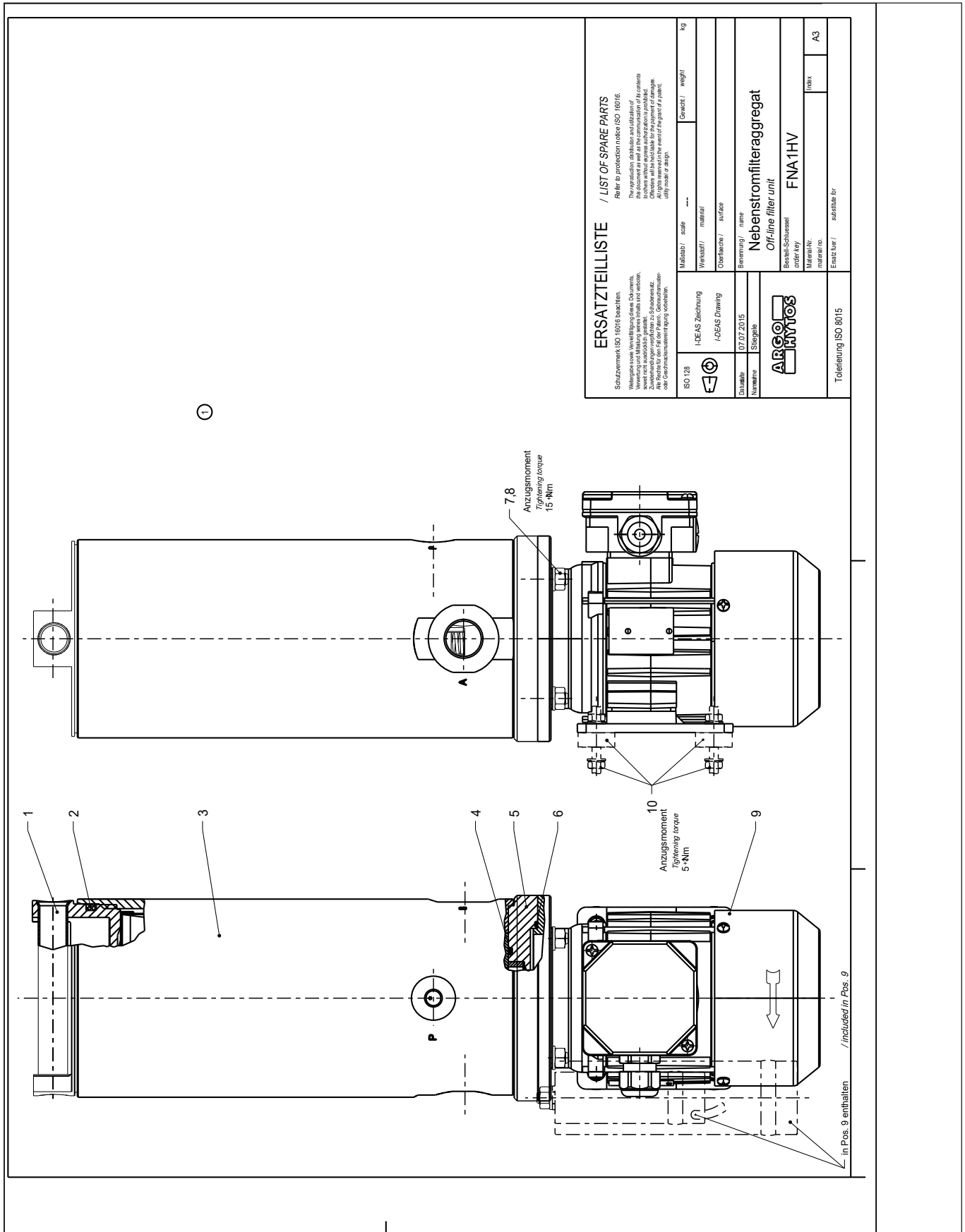

Fig. 9: Spare parts drawing FNA1HV

Position	Name	Order number	Unit code
1	Filter cover	43427300	All types
2	O-ring 117,48x5,33 NBR70	11899200	All types
3	Filter element	V7.1220-113	FNA1HV...V003
		V7.1220-13	FNA1HV...V005
		V7.1220-06	FNA1HV...V010
		V7.1220-05	FNA1HV...V007
		V7.1220-113	FNA1HV...V003
4	O-ring 63,09x3,53 NBR70	11726000	All types
5	Pump set	13376300	All types
6	O-ring 94,92x2,62 NBR70	11104400	All types
7	Washer M8; ISO 7090	11874600	All types
8	Hexagon nut M8; ISO 4032	11874700	All types
9	Electric motor	43621900	FNA1HV 005...40050
		43650100	FNA1HV 005...40050
10	Mounting set	34496400	All types

Table 12: Spare part list

Note: For other spare parts not listed in this manual please contact info.pl@argo-hytos.com

Installation declaration FNA1HV

We, the company,

ARGO-HYTOS Polska sp. z o.o.
Władysława Grabskiego 27
32-640 Zator, Poland,

declare on our sole responsibility that the products of product range

Off-line Filter Unit FNA1HV 005; FNA1HV 008; FNA1HV 016

to which this declaration refers, conforms to the following standards and normative documents:

Directive 2006/42/EC (Machinery Directive)
Directive 2014/30/UE (EMC Directive)

Conformity with the directives is assured through compliance with the following standards:

EN 809:1998+A1:2009/AC:2010
Pumps and pump units for liquids -Common safety requirements

EN 60204-1:2018
Safety of machinery -- Electrical equipment of machines -- Part 1: General requirements

Zator, 19.04.2021

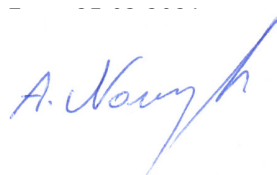

Arkadiusz Noworyta
AHPL Generaldirektor

Fig. 10: Installation declaration FNA1HV

International

ARGO-HYTOS worldwide

Benelux	ARGO-HYTOS B.V.	info.benelux@argo-hytos.com
Brazil	ARGO-HYTOS Fluid Power Systems Ltda.	info.br@argo-hytos.com
China	ARGO-HYTOS Fluid Power Systems	info.cn@argo-hytos.com
Czech Republic	ARGO-HYTOS s.r.o	info.cz@argo-hytos.com
	ARGO-HYTOS Protech s.r.o	info.protech@argo-hytos.com
France	ARGO-HYTOS SAS	info.fr@argo-hytos.com
Germany	ARGO-HYTOS GMBH	info.de@argo-hytos.com
Great Britain	ARGO-HYTOS Ltd.	info.uk@argo-hytos.com
Hong Kong	ARGO-HYTOS Hong Kong Ltd.	info.hk@argo-hytos.com
India	ARGO-HYTOS PVT. LTD.	info.in@argo-hytos.com
Italy	ARGO-HYTOS S.r.l.	info.it@argo-hytos.com
Poland	ARGO-HYTOS Polska spz o.o.	info.pl@argo-hytos.com
Sweden	ARGO-HYTOS Nordic AB	info.se@argo-hytos.com
Turkey	ARGO-HYTOS Hidrolik Ekip. San. ve Tic. Ltd. Şti.	info.tr@argo-hytos.com
USA	ARGO-HYTOS Inc.	info.us@argo-hytos.com

