

Filter Unit

FAPC 016



Safety and operating instructions

Read safety and operating instructions before use.

Note: The indicated data only serve to describe the product. Specifications regarding the use of this product are only examples and suggestions. Catalog specifications are no guaranteed features. The information given does not release the user from his / her own assessments and inspection.

Our products are subject to a process of natural wear and aging.

© All rights are reserved by ARGO-HYTOS GMBH, even in the event of industrial property rights. Any right of disposal such as copying and distribution rights shall remain with us.

The picture on the title page shows a configuration example. The delivered product may thus differ from the illustration.

Content

Content	2
1. About this documentation	4
1.1 Applicability of this documentation	4
1.2 Required and supplementary documentation	4
1.3 Presentation of information	4
1.3.1 Safety instructions	4
1.3.2 Symbols	5
1.3.3 Terms	5
1.3.4 Abbreviations	5
2. Safety instructions	6
2.1 About this chapter	6
2.2 Intended use	6
2.3 Improper use	6
2.4 Reasonable foreseeable misuse	6
2.5 Qualification of personnel	6
2.6 General safety instructions	6
2.7 Product and technology related safety instructions	7
3. General instructions	8
4. Scope of delivery	9
5. About this product	10
5.1 Performance description	10
5.2 Device description	10
5.3 Component overview	10
5.4 Identification of the product	11
6. Transport and storage	12
6.1 Transport	12
6.2 Storage	12
7. Assembly	13
8. Commissioning	14
8.1 Before commissioning	14
8.2 After switching on	14
8.3 In case of power failure	14
9. Operation	15
9.1 Filtering of hydraulic fluids with refilling.....	15
9.2 Filtering of liquids in the bypass flow	16
9.3 Data collection	17
9.4 Switching of the measuring type while filling or cleaning.....	17
10. Repair and maintenance	18
10.1 Maintenance	18
10.2 Maintenance overview.....	18
10.2.1 Replacing the suction strainer	19
10.3 Replacing the filter element	19
10.3.1 Removing the filter element	20
10.3.2 Removing the filter element from the cover	20
10.3.3 Attaching the filter element	20
10.3.4 Installing the filter element	21
10.3.5 Bleeding the filter element	21
10.4 Replacing the pump	22
10.4.1 Removing the pump	23
10.4.2 Installing the pump.....	23

10.5	Replacing the motor.....	24
10.5.1	Removing the motor.....	24
10.5.2	Installing the motor.....	24
10.6	Replacing the particle monitor OPCom.....	25
10.6.1	Removing the OPCom.....	25
10.6.2	Installing the OPCom.....	25
11.	Decommissioning.....	26
12.	Disassembly.....	27
13.	Disposal.....	28
14.	Extension.....	29
14.1	Optional accessories.....	29
14.1.1	Transport aid / trolley.....	29
14.1.2	Hose extensions.....	29
14.1.3	Suction strainer set.....	29
15.	Troubleshooting.....	30
15.1	How to proceed.....	30
15.2	Fault table.....	30
16.	Technical data.....	31
16.1	Dimensions.....	31
16.2	Technical data.....	31
16.3	Operating conditions.....	32
16.4	Hydraulic circuit diagram.....	32
17.	Appendix.....	33
17.1	Declaration of conformity.....	33
17.2	Spare parts list.....	34

1. About this documentation

1.1 Applicability of the documentation

This documentation is applicable for the following product:

- › Filter Unit FAPC 016

This documentation is written for technicians, operators, service engineers and system operators.

This document contains important information for safe and appropriate assembly, transport, activation, operation, usage, servicing, dismantling and simple troubleshooting.

- › Read this document completely and in particular Chapter 2, "Safety Instructions", before you work with the product.

1.2 Required and supplementary documentation

Do not commission the product until you have received the documentation marked with the book icon and before you have understood and complied with the information therein.

	Title	Document number	Document type
	Data sheet	8065_EN	
	Manual	OPCom	

Table 1: Required and supplementary documentation

1.3 Presentation of information

So that this document can help you to work quickly and safely with your product, we use standardized safety instructions, symbols, terms and abbreviations. For better understanding, these are explained in the following sections.

1.3.1 Safety instructions

In this documentation, safety instructions are faced with a sequence of actions which would result in the danger of personal injury or damage to equipment. The measures described to avoid these hazards must be observed.

Safety instructions are as follows:

 SIGNAL WORD
Type and source of danger Consequences of non-compliance <ul style="list-style-type: none">› Measures to avert dangers› <Enumeration>

- › Warning signal: draws attention to the danger
- › Signal word: indicates the severity of the danger
- › Type and source of danger: specifies the type and source of the danger
- › Consequences: describes the consequences in the event of non-compliance
- › Action: indicates how the danger can be avoided

Warning sign, signal word	Meaning
 DANGER	Indicates a dangerous situation which results in death or serious injury if not avoided.
 WARNING	Indicates a dangerous situation which may result in death or serious bodily injury if not avoided.
 CAUTION	Indicates a dangerous situation which may result in light to moderate injury if not avoided.
NOTE	Indicates property damage: The product or surrounding could be damaged.

Table 2: Hazard classes according to ANSI Z536.6-2006

1.3.2 Symbols

The following symbols indicate notes which are not safety-relevant but increase the intelligibility of the documentation.

Symbol	Meaning
	If this information is not observed, the product cannot optimally be used or operated.
>	Singular, independent action step / instruction
	This symbol specifies that protective gloves should be worn.
	This symbol specifies that safety shoes should be worn.
	This symbol specifies that protective goggles should be worn.

Table 3: Meaning of symbols

1.3.3 Terms

In this documentation the following terms are used:

Term	Meaning

Table 4: Terms

1.3.4 Abbreviations

In this documentation the following abbreviations are used:

Term	Meaning
FAPC	Filter unit with particle monitor

Table 5: Abbreviations

2. Safety instructions

2.1 About this chapter

This product was manufactured according to the generally recognized standards of engineering. Nevertheless, there is a danger of injury or damage if you do not observe this chapter and the safety instructions in this documentation.

- › Read this document thoroughly and completely before working with the product.
- › Retain this document and ensure that it is available for all users at all times.
- › Always include the necessary documentation when passing the equipment along to a third party.

2.2 Intended use

This product is a hydraulic component.

You may use the product for the following:

- › for filtering lubricants and hydraulic oils while filling machines and plants, taking the technical data into account
- › for filtering hydraulic fluids in the bypass flow on machines and plants, taking the technical data into account
- › for monitoring the oil cleanliness while filling machines and plants
- › for monitoring the oil cleanliness when cleaning in the bypass flow

This product is intended for professional use only and not for private use.

"Intended use" also includes that you have completely read and understood this documentation, in particular Chapter 2 "Safety Instructions".

2.3 Improper use

Any other use than the intended use described, is improper and inadmissible.

If unsuitable products are installed or used in safety-related applications, unintended operating states may occur in the application, which may cause personal injury and / or property damage.

Therefore only use this product in safety-related applications if this use is explicitly specified and permitted in the product documentation, e.g. in explosion protection areas or in safety-related parts of a control system (functional safety).

ARGO-HYTOS GMBH assumes no liability for damages resulting from improper use. The risks associated with improper use are solely with the user.

2.4 Reasonable foreseeable misuse

The delivery of the following media is forbidden:

- › highly flammable liquids such as petrol or thinner (explosion hazard)

The device is not suitable for the extraction of oil sludge and sediment.

The operator alone is liable for damages resulting from improper use.

2.5 Qualification of personnel

The operations described in this document require fundamental knowledge of mechanics and hydraulics as well as knowledge of the appropriate technical terms. In order to ensure safe use, these operations may therefore only be carried out by a correspondingly skilled worker or an instructed person under the guidance of a skilled worker.

A skilled worker is someone who can - based on his / her technical education, knowledge and experience as well as knowledge of the respective regulations of the jobs assigned to him / her - recognize possible dangers and ensure appropriate safety measures.

A skilled worker must observe the relevant technical regulations.

2.6 General safety instructions

- › Observe the valid regulations for accident prevention and environmental protection.
- › Observe the safety regulations and requirements of the country in which the product is used / applied.
- › Only use ARGO-HYTOS products that are in technically perfect condition.
- › Observe all instructions on the product.
- › People who assemble, operate, disassemble or maintain ARGO-HYTOS products may not do so under the influence of alcohol, other drugs or medications that affect the responsiveness.
- › Only use manufacturer-approved accessories and spare parts, in order to prevent personal danger due to unsuitable spare parts.
- › Observe the technical data and ambient specifications specified in the product documentation.

- › If unsuitable products are used or installed in safety-relevant applications, unintended operating states may occur in the application, which can cause personal injury and / or material damage. Therefore only use the product in safety-relevant applications if this use is explicitly specified and permitted in the product documentation.
- › You may only put the product into operation, when it has been established that the final product (e.g. a machine or system), into which the ARGO-HYTOS products have been installed, complies with the country-specific regulations, safety regulations and standards of the application.

2.7 Product and technology related safety instructions

 CAUTION	
	<p>Leaked hydraulic oil Environmental hazard / risk of slipping</p> <ul style="list-style-type: none"> › In case of spills, cover the oil-covered surface immediately with an oil-binding medium. › Then immediately dispose of the oil-binding medium according to the national environmental regulations.
	<p>Ignition hazard Risk of electrostatic charge by poorly conducting hydraulic fluid</p> <ul style="list-style-type: none"> › If the electrical conductivity of the hydraulic fluid is not known, please contact the manufacturer of the hydraulic fluid.
	<p>Risk of burns Contact temperatures according to DIN EN563 (3) and DIN EN13202 (4) may be exceeded during operation</p> <ul style="list-style-type: none"> › Allow the filter unit to cool down before touching it.

For prevention of material damage and product damage



CAUTION



Danger due to improper handling

Property damage

- › The filter unit may only be used in accordance with Section 2.2, "Intended use".

Leakage or spillage of hydraulic fluid

Environmental pollution and ground water contamination

- › Use oil binding agents in order to bind leaked hydraulic oil.



Risk of burns

Contact temperatures according to DIN EN563 (3) and DIN EN13202 (4) may be exceeded during operation.

- › Allow the filter unit to cool down before touching it.

Contamination due to fluids and foreign bodies

Premature wear, malfunction, risk of damage, property damage.

- › Ensure cleanliness during installation in order to prevent foreign bodies, such as welding beads or metal chips, from entering the hydraulic lines, leading to premature wear or malfunction.
- › Make sure that connections, hydraulic lines and attachment parts (e.g. gauges) are free from dirt and chips.
- › Prior to commissioning, check that all hydraulic and mechanical connections are connected and tight, and that all gaskets and seals of the plug connectors are correctly assembled and undamaged.
- › For removal of lubricants and other contaminants, use residue-free industrial wipes.
- › Make sure that all connections, hydraulic lines and attachment parts are clean.
- › Ensure that no contaminants enter when closing the connections.
- › Make sure that no detergents enter the hydraulic system.
- › Do not use cotton waste or faying cleaning rags for cleaning.
- › Do not use hemp as sealing agent.



Improper cleaning

Premature wear, malfunction, risk of damage, property damage.

- › Close all openings with appropriate protective fittings to prevent penetration of detergents.
- › Do not use aggressive cleaning agents for cleaning. Clean the product with a suitable cleaning fluid.
- › Do not use a high pressure cleaner.
- › Do not use compressed air to clean function interfaces such as seal areas.

4. Scope of delivery

This package includes:

- › 1 Filter Unit FAPC 016
- › 1 Operating manual

5. About this product

5.1 Performance description

The filter unit FAPC 016 is a mobile filter system for filtering hydraulic fluids and lubricants with a viscosity of 15 mm²/s (min. in continuous operation) - 150 mm²/s in the bypass flow (300 mm²/s max. during short-term operation). A separate installation in the bypass flow or cooling circuit for fine filtration and relief of the main flow filter is also possible, as is the filtration of fresh oil and the cleaning (flushing) of contaminated systems for the wear protection of components and systems. The volume flow is 16 l/min. The operating temperature range is from 0 °C to 60 °C.

5.2 Device description

The filter unit FAPC 016 consists of a support frame in which a filter pump unit is integrated. It consists of an electronically operated filter pump with a replaceable filter element and a pressure gauge as a maintenance indicator. The on-off switch is located on the control box of the pump motor. The suction hose is connected at the suction side connection of the pump and the pressure hose is connected at the main filter outlet.

The particle monitor OPCOM can be configured and programmed directly on the device.

Measurement data can be transferred to a PC by means of an RS232 interface and then saved for processing on the PC.

5.3 Component overview

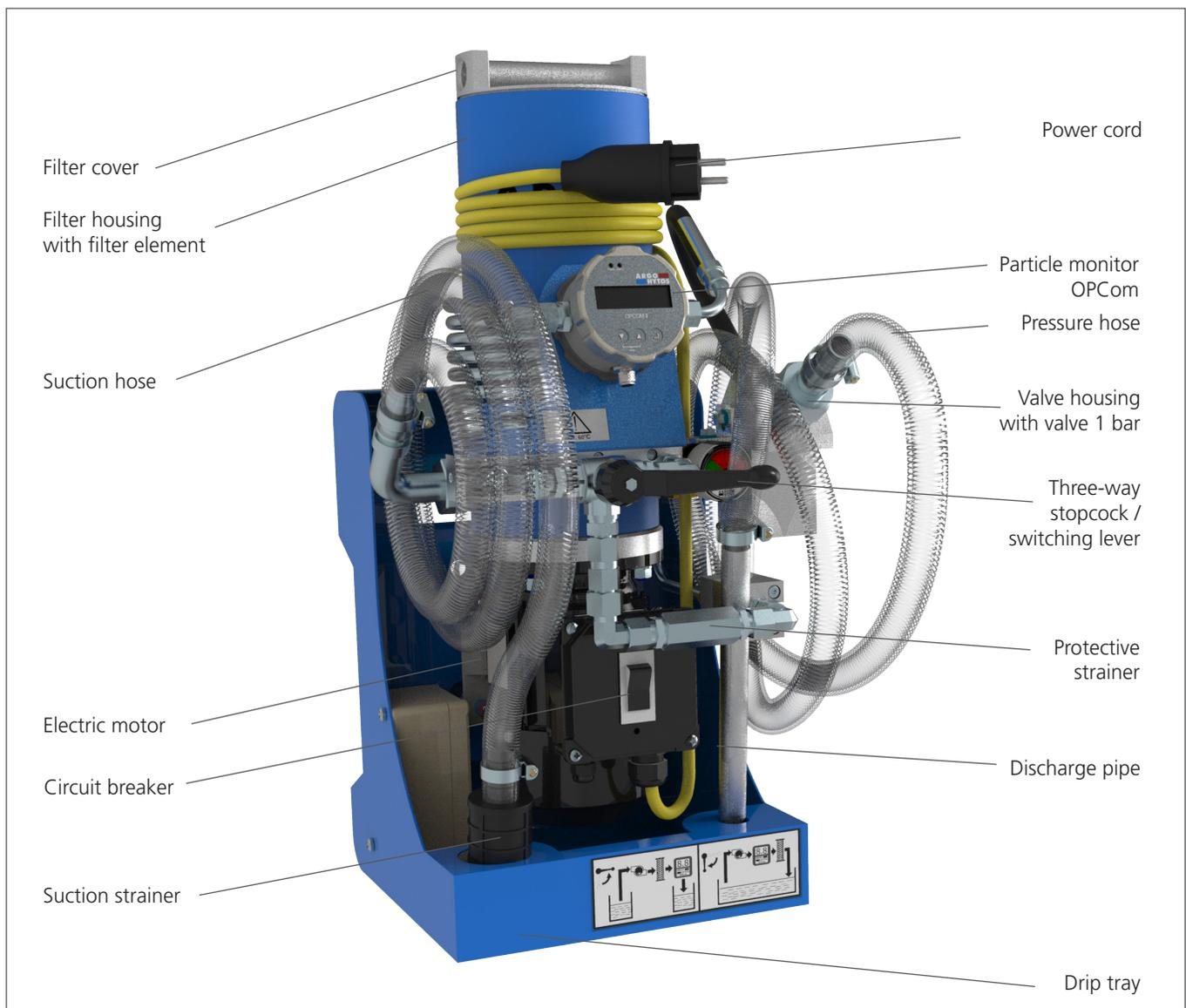

Fig.1: Component overview

5.4 Identification of the product

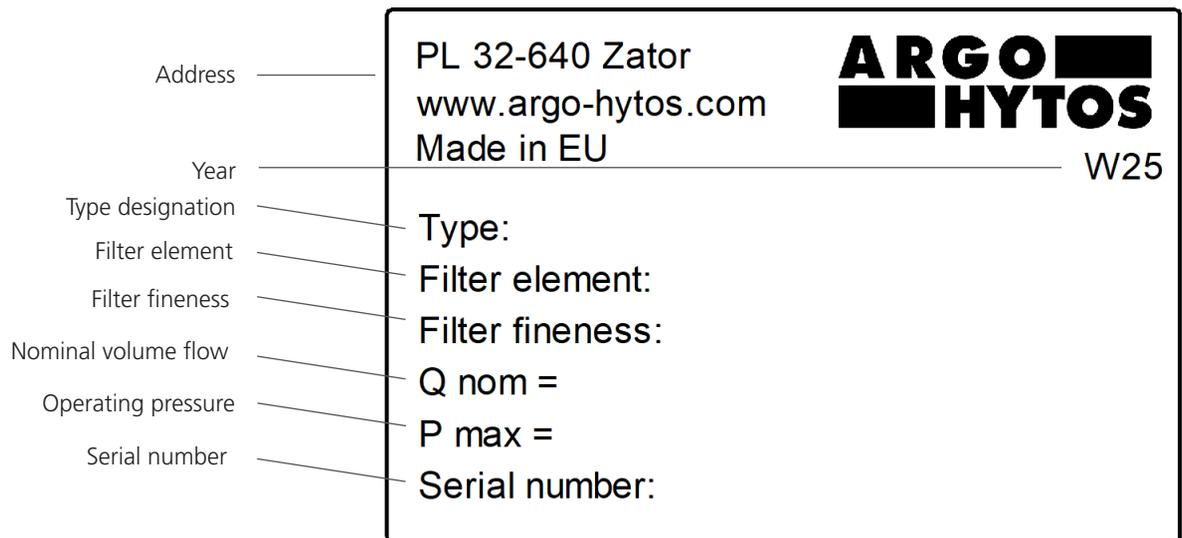

Fig. 2: Nameplate

6. Transport and storage

6.1 Transport

CAUTION



Falling unit by incorrect transport **Injuries! Damage!**

- › Due to its weight of 22 kg, the device must be carried manually by two persons.
- › Wear safety shoes when transporting the filter unit.



The compact design allows for easy transport of the FAPC 016 filter unit – even to inaccessible parts of hydraulic systems. Hoses and electrical cables can be attached to the device. The device can be transported and operated both standing upright and lying flat. Please note the instructions in Chapter 2 "Safety instructions".

- › When using mobile transport aids, ensure a secure position of the unit (danger of tipping).
- › During transport, secure the suction hose and the pressure hose in the brackets provided for this purpose in order to avoid a possible leakage of residual oil.

Fig.3: Transport by carrying

6.2 Storage

The filter unit FAPC 016 should be stored in an enclosed area to protect it from humidity and condensation.

DANGER



Risk of injury **Danger of chemical reactions**

Chemical substances in the immediate vicinity of the filter unit can react and lead to the destruction of the device and to injuries to persons in the immediate vicinity of the device.

- › Storage in the immediate vicinity of chemically active substances such as acids, alkalis, salts, organic solvents and rechargeable batteries is prohibited.

The ambient temperature during storage of the filter unit FAPC 016 should be between +5 °C und +50 °C at a maximum humidity of 80 %.

Before storage over a period of more than 6 months, the device should be filled with oil in order to preserve it against corrosion.

**Faulty power supply****Risk of death! Risk of injury!**

- › Always consider the country-specific regulations.

Let - prior to commissioning - an electrician check whether:

- › the mains voltage matches with the voltage specified on the nameplate of the motor,
- › the power source has appropriately been secured,
- › the cross-section is of sufficient size,
- › cable and connection to the power source are in perfect condition.

With 3-phase AC motors check after connecting that:

- › when switching on, the direction of rotation matches with the direction arrow on the motor, if not, have it changed by an electrician.

The following steps are to be followed in detail:

- › connect the 230V voltage plug to the local power supply.

8.1. Before commissioning

- › Be sure to read and understand the operating manual before putting the device into operation.
- › The information for intended use, the operating conditions and the technical specifications must be adhered to.
- › The unit must be positioned so that there is no danger of tipping and vibrations are largely intercepted.
- › Cables and hoses must be outside of the movement range of the operating personnel (tripping hazard).
- › If no hydraulic oil is sucked in during commissioning, switch off the unit, open the cover at the filter housing and fill in approx. 0.3 l hydraulic oil.
- › The oil to be filtered must be compatible with the previously filtered hydraulic oil. If this is not the case, the filter unit must be cleaned and the filter element is to be replaced (see filter element change).
- › When using the hoses during unmanned operation, ensure that they might not fall out of the container.
- › The suction and discharge pipe must be immersed far enough below the liquid level, so that oil is sucked in.
- › The hydraulic fluid must be free of water (no oil turbidity).
- › Measurement results are falsified by free water in the oil.
- › Properly close the cover of the filter housing.
- › Manually turn the cover until it stops; a gap between cover and housing may remain visible (see Figure 3).

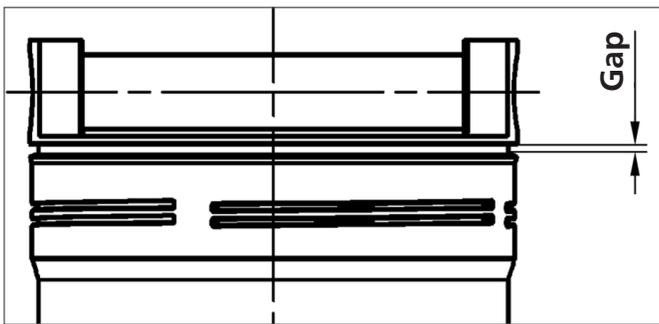

Fig. 4: Gap at the filter cover

8.2 After switching on

- › With 3-phase AC motors check after connecting if the direction of rotation matches with the direction arrow on the motor. If not, have it changed by an electrician.
- › Check the filter unit for leaks.
- › Check that the device is properly vented. To do so, open the hexagon socket screw on the cover slightly until oil emerges. Then close the hexagon socket screw. Air bubbles in the oil falsify the measuring result.

8.3 In case of power failure

In order to prevent unintentional starting of the unit, always switch off and unplug the unit.

 **CAUTION**

	<p>Danger resulting from spilled oil Injury! Risk of slipping!</p> <ul style="list-style-type: none"> › If oil leaks, the oil-covered area must be shut off immediately and covered with an oil binding medium (risk of slipping). <p>Static charge Sparking</p> <ul style="list-style-type: none"> › There is a risk of static charge when using poorly conducting hydraulic or lubricating oils. In this case, please consult the manufacturer.
---	---

NOTE

	<p>Damage to the filter unit by missing or defective suction strainer Property damage!</p> <ul style="list-style-type: none"> › The strainer must be regularly checked according to the maintenance intervals and replaced if necessary. <p>Inaccurate measurement results Incorrect measurements</p> <ul style="list-style-type: none"> › The measured values from the first five minutes should not be taken into account, as the particle counter needs to initialize, and the hydraulic circuit must stabilize (air bubbles, flushing, etc.). › The filter unit is provided with a protective strainer at the suction side, which has to be serviced regularly. A missing protective strainer may lead to destruction of the pump. (Order No. see spare parts list) › If the protective strainer is removed, the manufacturer will assume no liability.
---	---

9.1 Filtering of hydraulic fluids with refilling

1. Connect the filter unit to a power source.
2. Place the suction strainer into the oil drum.
3. Place the discharge pipe into a container (e.g. hydraulic tank).

NOTE

	<p>Faulty insertion of the discharge pipe</p> <ul style="list-style-type: none"> › Make sure that the discharge pipe is below the liquid surface.
---	---

4. Turn the filter unit on at the on/off switch (circuit breaker).
5. Check the oil flow on possibly insufficient immersion depth of the suction pipe in the oil tank.

NOTE

	<ul style="list-style-type: none"> › At the beginning of the filtration, filling of the filter unit may take a few seconds.
---	--

6. Using the clogging indicator, check the element for clogging at operating temperature of the medium used.
7. Check the filling level at the machine or system and turn off the filter unit at the circuit breaker, once the desired filling quantity has been reached.
8. Re-attach the suction strainer and the discharge pipe to the appropriate brackets at the filter unit.

9.2 Filtering of liquids in the bypass flow

1. Connect the filter unit to a power source.
2. Place the suction strainer into the container of the machine or system (e.g. hydraulic tank).
3. Place the discharge pipe in a container of the machine or system (e.g. hydraulic tank).

NOTE



Faulty insertion of the discharge pipe

- › Make sure that the discharge pipe is below the liquid surface.

4. Turn the filter unit on at the on/off switch (circuit breaker).
5. Check the oil flow on possibly insufficient immersion depth of the suction pipe in the oil tank.

NOTE



- › At the beginning of the filtration, filling of the filter unit may take a few seconds.

6. Using the clogging indicator, check the element for clogging at operating temperature of the medium used.
7. At the end of filtration, pull the suction strainer out of the container of the machine or system (e.g. hydraulic tank) and draw in air for max. 30 seconds.
Thus, residual oil from the filter housing and the lines above oil level will be returned via the discharge pipe into the tank of the machine or unit.
8. Turn off the filter unit by using the circuit breaker.
9. Re-attach the suction strainer and the discharge pipe to the appropriate brackets at the filter unit.

NOTE



Reaching the maximum cleaning performance

- › In order to prevent a short circuit of the oil flow, the distance between the suction and pressure connection should be kept as large as possible.

Falsification of the measuring results

- › Make sure that the device is properly vented.

9.3 Data collection

The filter unit FAPC 016 is equipped with a data memory that can store up to 3,000 results.

Once the storage capacity is reached, the last measured value is saved, while the oldest measured value is simultaneously overwritten.

NOTE



A description for installation and data transmission is available in the OPCom user manual.

1. Connect a data cable to the RSR232 socket (Fig. 1 Pos. 13).
2. Connect the plug to a PC or laptop on which the corresponding software is installed.

NOTE



The corresponding software can be downloaded from www.argo-hytos.com.

The stored results are transferred to the hard disk of the connected PC or laptop and can be stored there.

9.4 Switching of the measuring type while filling or cleaning

When monitoring the cleanliness class, a ball valve can be used to switch between "downstream of filter" (e.g. when filling the equipment) and "upstream of filter" (e.g. when cleaning out oil fillings).

Switch positions are changed using the attached three-way stopcock (Fig. 1 Pos. 6).

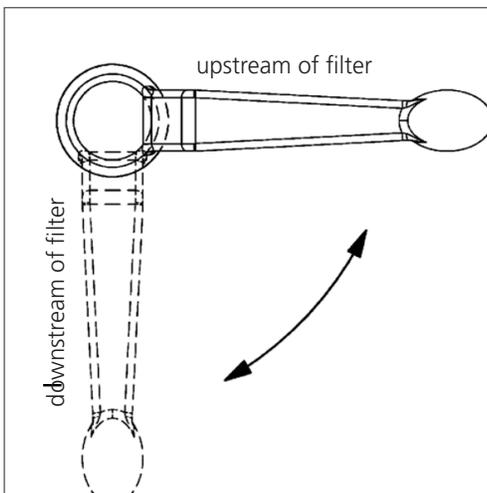

Fig. 5: Three-way stopcock

Switch position upstream of filter

- › horizontal level position
- › the oil cleanliness is monitored during the cleaning process

Switch position downstream of filter

- › vertical lever position
- › the oil cleanliness is monitored during the filling process

DANGER



Danger to life **Risk of electric shock**

- › During repair work, turn off the unit and pull the mains plug.

CAUTION



Leaked hydraulic oil **Environmental hazard / risk of slipping**

- › Before maintenance and repair work, completely drain the unit.
- › In case of spills, cover the oil-covered surface immediately with an oil-binding medium.
- › Then immediately dispose of the oil-binding medium according to the national environmental regulations.

Ignition hazard

Risk of electrostatic charge by poorly conducting hydraulic fluid

- › If the electrical conductivity of the hydraulic fluid is not known, please contact the manufacturer of the hydraulic fluid.

Risk of burns

Contact temperatures according to DIN EN563 (3) and DIN EN13202 (4) may be exceeded during operation.

- › Allow the filter unit to cool down before touching it.

NOTE



Impaired function by dirt ingress into the pump **The function of the filter unit is no longer guaranteed.**

- › During repair work, all parts coming in contact with the hydraulic medium, must be kept free of dirt and chips.

10.1 Maintenance

10.2 Maintenance overview

Except from the filter element and the suction strainer, the filter unit is maintenance-free.

Maintenance work	Order No.	Maintenance interval
Checking / changing the filter element	V7.1220-113 (3 µm)	Once the clogging indicator responds with admissible viscosity
Checking / changing the suction strainer	FA 016.0301	Quarterly or with corresponding problems (lower volume flow with clean filter element, too loud noise level)

10.2.1 Replacing the suction strainer

NOTE



Damage to the filter unit by missing or defective suction strainer.

Property damage

- › The suction strainer must be regularly checked and replaced if necessary, according to the maintenance intervals.

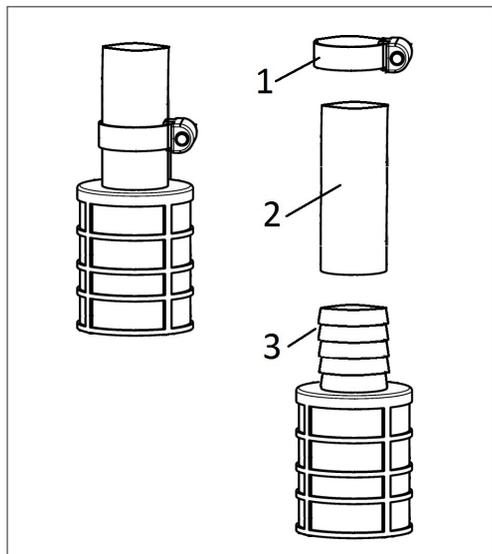

1. Loosen the hose clamp (1).
2. Pull the suction hose (2) from the suction strainer (3).
3. Clean the suction strainer (3) with benzine or diesel fuel.
4. Push the suction hose (2) - as shown above - onto the suction strainer (3).
5. Attach the hose clamp (1).

Fig. 6: Replacing the suction strainer

NOTE



- › In case of damage, replace the suction strainer (3) (Order No. FA 016.0100).

10.3 Replacing the filter element

1. Pump the filter element dry (see chapter 9.2 "Filtering liquids in the bypass flow" Point 7).
2. Turn the filter unit off at the on/off switch (circuit breaker) and pull the mains plug.

CAUTION



Risk of burns

Contact temperatures according to DIN EN563 (3) and DIN EN13202 (4) may be exceeded during operation.

- › Allow the filter unit to cool down before touching it.

10.3.1 Removing the filter element



Fig. 7: Removing the filter element

1. Turn the housing cover (1) counterclockwise.
2. Carefully remove the cover (1) with the filter element (2) from the filter tube.
(The filter element is attached to the cover.
Let the draining oil drip off into the housing.)

10.3.2 Removing the filter element from the cover



Fig. 8: Removing the filter element from the cover

1. Push the filter element at the cover in arrow direction 1 and remove it in arrow direction 2.
2. Dispose of the filter element according to the national environmental legislation (Waste code: Oil filter 16 01 07).

10.3.3 Attaching the filter element



Fig. 9: Attaching the filter element

1. Check the filter element type number.
Does the laser inscription on the filter element match with the indications on the type plate or in the operating manual?
2. Attach the filter element in arrow direction 2 and lock it in arrow direction 1.

10.3.4 Installing the filter element



Fig. 10: Installing the filter element

1. Always replace the O-ring in the cover, when changing the filter element (part of the scope of delivery of the filter element) (O-ring Order No. N007.1175, included in spare filter elements).
2. Carefully insert the cover (1) with the filter element (2) into the filter tube.
3. Screw in the cover manually until it stops.
A gap between cover and filter pipe may remain visible (see Chapter 8.1 "Before commissioning" / Fig. 3)

10.3.5 Bleeding the filter element



Abb. 11: Bleeding the filter element

1. Open the bleed screw (1).
2. Plug in the mains plug and put the filter unit back into operation. When oil begins to run out from the vent opening, reseal the vent opening by tightening the bleed screw (1).
3. Check whether the ventilation slots of the electric motor are contaminated and remove any deposits that may be present.
4. Restart the unit.
5. Check the filter housing for leaks after commissioning.

! DANGER

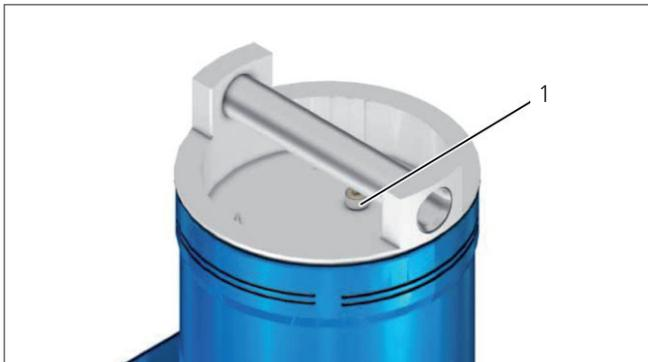

Danger to life
Risk of electric shock

› Before uninstalling, pull the mains plug. Uninstalling may only be carried out by qualified electricians.

Risk of injury
Risk of injury by incorrect handling

› Uninstalling may only be carried out by instructed persons.

! CAUTION



Risk of burns
Contact temperatures according to DIN EN563 (3) and DIN EN13202 (4) may be exceeded during operation.

› Allow the filter unit to cool down before touching it.

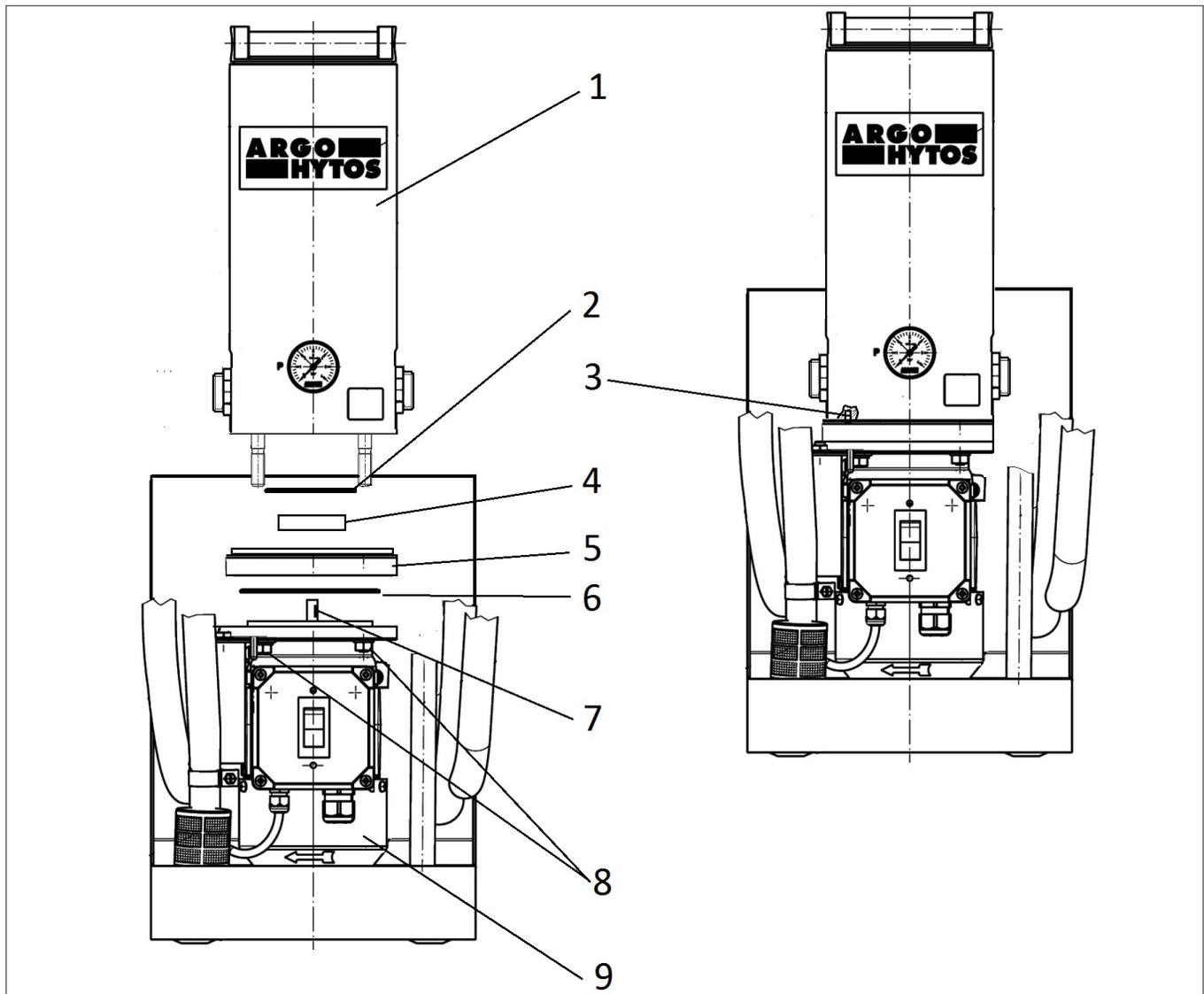

Fig. 12: Replacing the motor and the pump

10.4.1 Removing the pump

1. Loosen the hexagon nuts (Pos. 8).
2. Lift the filter housing (Pos. 1) together with the attached measuring sensor upwards.
3. Loosen the pump plate (Pos. 5) together with the wheel set (consisting of outer rotor and inner rotor, Pos. 4) from the motor (Pos. 9) by gently pulling them upwards.
4. Dispose of the pump plate, the wheel set and the O-rings according to the national environmental legislation.

NOTE



- › When replacing the pump, the O-rings (Pos. 2 and Pos. 6) must always be replaced by new O-rings. Please take the Order No. from the spare parts list.

10.4.2 Installing the pump

1. Assemble the outer and the inner rotor (Pos. 4) and place them into the designated cut-out in the pump plate. The installation position is optional.
2. Lubricate the O-rings (Pos. 2 and Pos. 6) and insert them into the provided O-ring grooves in the pump plate.
3. Attach the preassembled pump plate (Pos. 5 with Pos. 4) onto the motor (Pos. 9). Insert the key of the motor shaft (Pos. 7) in one of the four key grooves of the inner rotor.

NOTE



- › When pressing the pump plate onto the motor, please check that the O-ring (Pos. 6) does not slide out of the O-ring groove and will be damaged between motor and pump plate.
- › The hole for the pin (rotation lock Pos. 3) must be opposite of the terminal box (motor Pos. 9).

4. Wet or fill the wheel sets of the pump with oil.
5. Re-attach the filter housing (Pos. 1) to the pump plate and the motor.

NOTE



- › When mounting the filter pipe, ensure that the O-ring (Pos. 2) does not slide out of the O-ring groove and will be damaged between the pump plate (Pos. 5) and the housing (Pos. 1).

6. Screw the assembly with the nuts (Pos. 8) (tightening torque 15⁺² Nm).

The device can be put into operation.

If not oil is sucked during commissioning, open the cover at the filter housing and fill in about 300 ml oil.

10.5 Replacing the motor



DANGER



Danger to life

Risk of electric shock

- › Before uninstalling, pull the mains plug. Uninstalling may only be carried out by qualified electricians.

Risk of injury

Risk of injury by incorrect handling

- › Uninstalling may only be carried out by instructed persons.



DANGER



Risk of burns

Contact temperatures according to DIN EN563 (3) and DIN EN13202 (4) may be exceeded during operation.

- › Allow the filter unit to cool down before touching it.

10.5.1 Removing the motor

1. Loosen the hexagon nuts (Pos. 8).
2. Lift the filter housing (Pos. 1) together with the attached measuring sensor upwards.
3. Loosen the pump plate (Pos. 5) together with the wheel set (consisting of outer rotor and inner rotor, Pos. 4) from the motor (Pos. 9) by gently pulling them upwards
4. Loosen the motor (Pos. 9) from the bracket.
5. Dispose of the motor according to the national environmental legislation.

NOTE



- › When replacing the pump, the O-rings (Pos. 2 and Pos. 6) must always be replaced by new O-rings. Please take the Order No. from the spare parts list.

10.5.2 Installing the motor

1. Mount the motor (9) onto the bracket.
2. Lubricate the O-rings (Pos. 2 and Pos. 6) and insert them into the provided O-ring grooves in the pump plate.
3. Attach the preassembled pump plate (Pos. 5 with Pos. 4) onto the motor (Pos. 9).
Insert the key of the motor shaft (Pos. 8) in one of the four key grooves of the inner rotor.

NOTE



- › When pressing the pump plate onto the motor, please check that the O-ring (Pos. 6) does not slide out of the O-ring groove and will be damaged between motor and pump plate.
- › The hole for the pin (rotation lock Pos. 3) must be opposite of the terminal box. (Motor Pos. 9).

4. Wet or fill the wheel sets of the pump with oil.
5. Re-attach the filter housing (Pos. 1) to the pump plate and the motor.

NOTE



- › When mounting the filter pipe, ensure that the O-ring (Pos. 2) does not slide out of the O-ring groove and will be damaged between the pump plate (Pos. 5) and the housing (Pos. 1).

6. Screw the assembly with the nuts (Pos. 8) (tightening torque 15+2 Nm).

The device can be put into operation.

If not oil is sucked during commissioning, open the cover at the filter housing and fill in about 300 ml oil.

10.6 Replacing the particle monitor OPCom

 **DANGER**

	<p>Danger to life Risk of electric shock</p> <ul style="list-style-type: none"> › Before uninstalling, pull the mains plug. Uninstalling may only be carried out by qualified electricians. <p>Risk of injury Risk of injury by incorrect handling</p> <ul style="list-style-type: none"> › Uninstalling may only be carried out by instructed persons.
---	---

 **CAUTION**

	<p>Risk of burns Contact temperatures according to DIN EN563 (3) and DIN EN13202 (4) may be exceeded during operation.</p> <ul style="list-style-type: none"> › Allow the filter unit to cool down before touching it.
---	---

10.6.1 Removing the OPCom

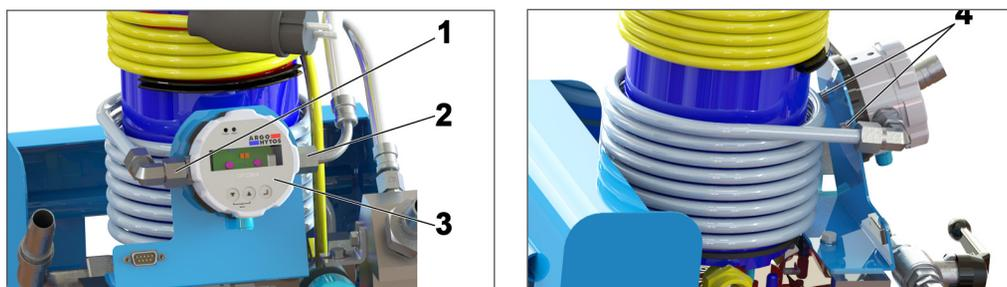

Fig. 13: Replacing the measuring sensor

1. Unplug the power cord from the bottom of the OPCom (cable not shown).
2. Loosen the angle screw connection at the inlet (1) and outlet (2).
3. Loosen the hexagonal screws (4).
4. Raise the particle monitor (3).

 **DANGER**

	<p>Danger to life Risk of electric shock</p> <ul style="list-style-type: none"> › Before uninstalling, pull the mains plug. Uninstalling may only be carried out by qualified electricians.
---	--

10.6.2 Installing the OPCom

The installation is carried out in reverse order as described above.



Danger to life

Risk of electric shock

- › Before uninstalling, pull the mains plug. Uninstalling may only be carried out by qualified electricians.

Risk of injury

Risk of injury by incorrect handling

- › Uninstalling may only be carried out by instructed persons.

The final decommissioning and disposal requires complete uninstallation of the total energy supply, the mechanical components and the disposal of the hydraulic media remaining in the device.

With disassembly and disposal, all national safety and environmental regulations must be observed.

The filter unit is a device which does not have to be dismantled.

13. Disposal

Careless disposal of the filter unit FAPC 016 and the hydraulic fluid can lead to environmental pollution. Therefore, dispose of the filter unit and the hydraulic fluid in accordance with the national regulations of your country. Dispose of hydraulic fluid residues according to the applicable safety data sheets for these hydraulic fluids.

14.1 Optional accessories

14.1.1 Transport aid / trolley

For easy transport of filter unit FAPC 016 it is possible to hook a trolley onto the standing device. This allows effortless transport even over long distances.



Fig. 14: Optional accessory "Trolley"

14.1.2 Hose extensions

On request, ARGO-HYTOS also provides you with hose extensions according to your stipulations.

14.1.3 Suction strainer set

Order No. FA 016.1775

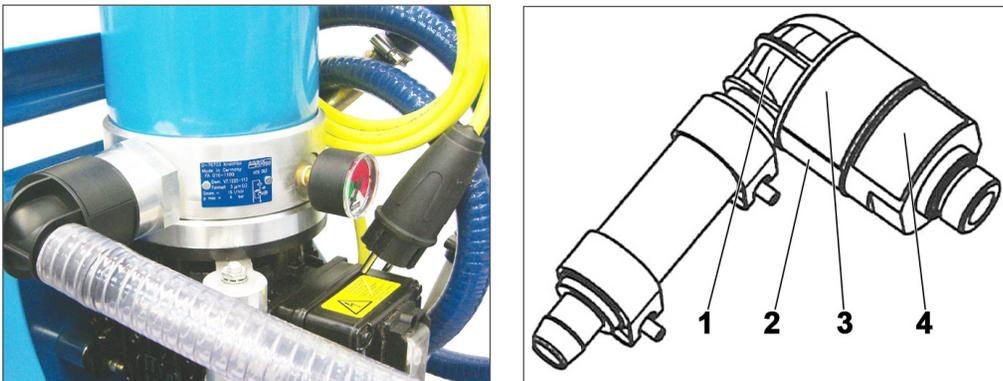

Fig. 15: Option "Suction strainer set"

The suction strainer set FA 016.1775 guarantees pump protection, when the existing suction strainer at the suction pipe cannot be used. This is the case, when the filter unit is to be mounted to the hydraulic unit by quick fitting coupling or ball valve, or the opening of the tank is not sufficiently dimensioned.

The suction strainer set FA 016.1775 consists of the suction strainer element 280 µm (2), a clip (3), a connection part with O-ring (4) and a connection piece (1).

The suction strainer set FA 016.1775 is designed in a way, so that the DN 25 hose connection can be rotated by 360° and thus be adapted to the position of the hose inlet.

15. Troubleshooting

15.1 How to proceed

- › Get an overview on the function of the product in connection with the overall system.
- › Try to find out whether the product had provided the required function in the overall system before the error occurred.
- › Try to detect changes in the overall system, into which the product has been installed:
 - Have the operating conditions or the operating range of the product changed?
 - Have modifications (e.g. conversions) or repairs been carried out at the overall system (device / unit, electrics, control) or at the product? If so, which modifications?
 - Has the product or the device been operated correctly?
 - How does the fault tend to show?
- › Get a clear impression about the cause of trouble. Possibly consult the direct operator or machine operator.

15.2 Fault table

Problem / fault	Possible cause	Elimination
Electric motor does not turn on during commissioning	<ul style="list-style-type: none"> › Electrical cable or mains plug defective › Supply voltage missing › On/off switch defective › Motor defective › Pump defective › Viscosity too high (medium) 	<ul style="list-style-type: none"> › Have cable replaced by a skilled electrician › Establish the power supply or activate the electric fuse › Replace on/off switch › Replace motor (repair at manufacturer's premises) › Replace pump (repair at manufacturer's premises) › Heat medium
Electric motor switches off during operation	<ul style="list-style-type: none"> › Electric motor is overheated › Pump is blocked 	<ul style="list-style-type: none"> › Let the motor cool down, clean any contaminated ventilation slits › Replace pump (repair at manufacturer's premises)
Volume flow is clearly too low	<ul style="list-style-type: none"> › Filter element contaminated › Suction strainer contaminated › Viscosity too high › Suction height too large › Leak on the suction side › Wear of the pump 	<ul style="list-style-type: none"> › Replace filter element › Replace / clean suction strainer › Heat medium › Adjust suction height › Replace suction hose or seal connection points (re-tighten them) › Replace pump (repair at manufacturer's premises)
Operating noise too loud	<ul style="list-style-type: none"> › Filter element contaminated › Suction strainer contaminated › Viscosity too high › Suction height too large › Leak on the suction side › Filter unit standing on a vibration-sensitive surface (e.g. sheet metal) 	<ul style="list-style-type: none"> › Replace filter element › Replace / clean suction strainer › Heat medium › Adjust suction height › Replace suction hose or seal connection points (re-tighten them) › Improve site conditions
Pump does not suck	<ul style="list-style-type: none"> › Leak on the suction side › Unit pumped empty (with refilling) › Suction strainer clogged 	<ul style="list-style-type: none"> › Replace suction hose or seal connection points (re-tighten them) › Prime the unit (0,3 l) › Clean / replace suction strainer
Oil on the fan wheel cover Oil leaking out of terminal box	<ul style="list-style-type: none"> › Shaft seal leaky › Residual oil at the housing after filter element change › Screwing leaky 	<ul style="list-style-type: none"> › Replace motor (repair at manufacturer's premises) › Clean filter unit › Check screw joints, re-tighten and / or seal them

Table 6: Fault table

16.1 Dimensions

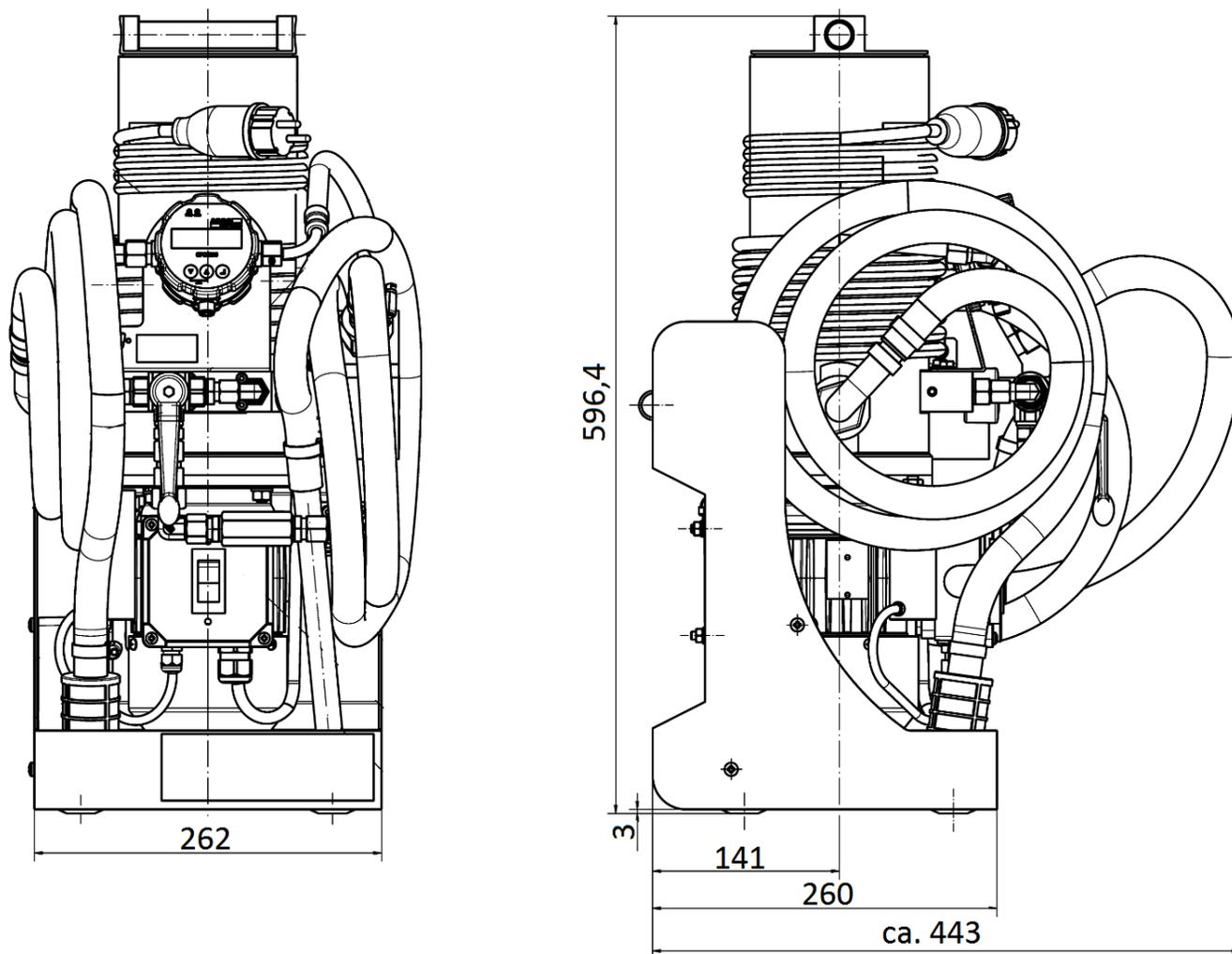

Fig. 16: Device dimensions

16.2 Technical data

Nominal flow rate	l/min (50 Hz) l/min (60 Hz)	16 19.2
Pressure limiting valve	bar	5 ± 0.5
Max. operating pressure	bar	4
Filter element		V7.1220-113 β ₅ (c) ≥ 200
Clogging indicator		Pressure gauge DG 200-17 green: 0 - 2.7 bar red: from 2.7 bar onwards
Suction side		Hose DN 20 with suction strainer
Pressure side		Hose DN 20 with discharge pipe
Suction strainer		Filter element 280 μm
Electric drive		1phase 230 V Motor 230 V; 50 Hz; 0.45 kW 230 V; 60 Hz; 0.54 kW
Tare weight	kg	approx. 24
Sound power level	db(A) max.	68 (under operating conditions permitted for continuous operation)

Table 7: Technical data

16.3 Operating conditions

CAUTION



Risk of burns

Contact temperatures according to DIN EN563 (3) and DIN EN13202 (4) may be exceeded during operation.

- › Allow the filter unit to cool down before touching it.

NOTE



Varying viscosity behavior

- › Viscosities of a medium are always temperature-dependent.

Electric drive 1~230 V 50/60 Hz	mm ² /s (min. continuous operation) mm ² /s (max. continuous operation)	15 150
Admissible temperature range	Hydraulic fluid °C Ambient temperature °C	10 ... 65 0 ... 60
Admissible suction heights	m (max.) first use m (max.) operating status	0.5 1.5
Media resistance		Hydraulic fluids based on mineral oil, rapeseed oils and synthetic esters
Work position		Optionally, preferably standing

16.4 Hydraulic circuit diagram

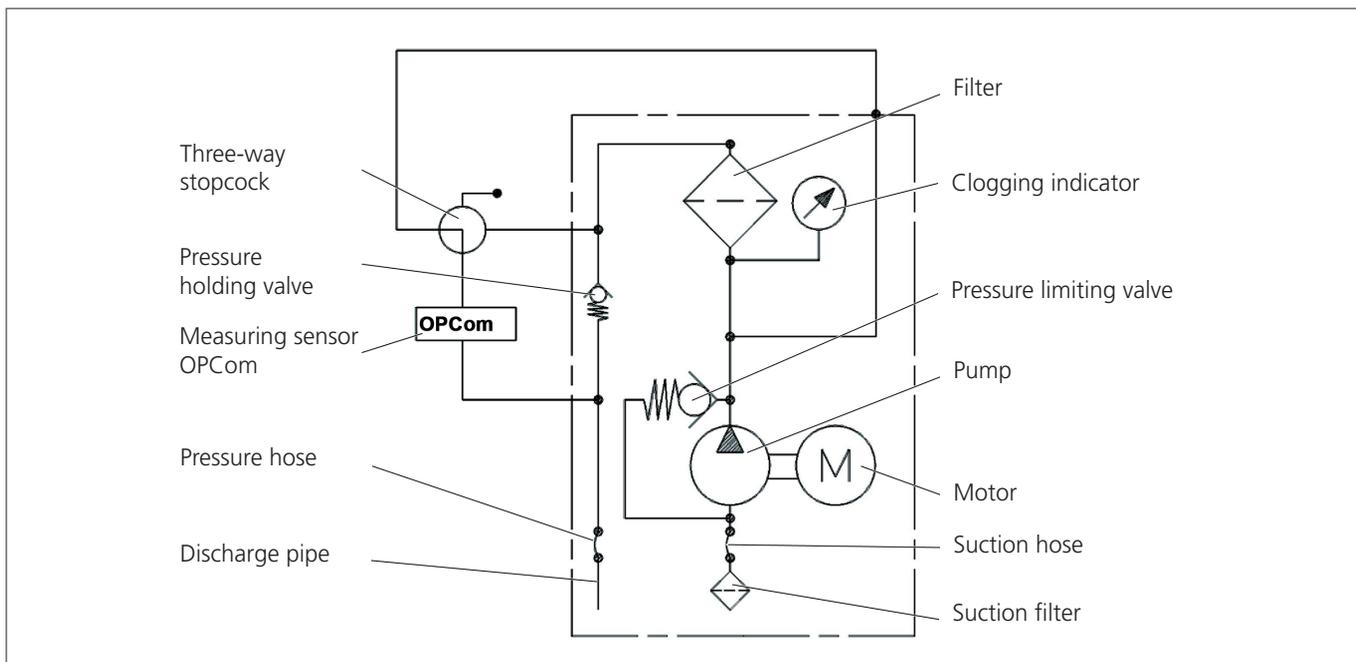

Fig. 17: Hydraulic circuit diagram

17.1 Declaration of conformity

EC Declaration of Conformity

We, the company,

ARGO-HYTOS Polska sp. z o.o.
Władysława Grabskiego 27
32-640 Zator, Poland,

declare on our sole responsibility that the products in the model series

Filter unit FAPC 016

to which this declaration pertains are in conformity with the following directives:

Directive 2006/42/EC (Machinery Directive)

Directive 2004/108/EC (EMC Directive)

Conformity with the directives is assured through compliance with the following standards:

DIN EN 809

Pumps and Pump Units for Liquids

DIN EN 60204-1 (VDE 0113-1: 2007-06)

Safety of machinery - Electrical equipment of machines - Part 1 General requirements (IEC 60204-1:2005, modified);
German version EN 60204-1:2006

Zator, 26.05.2017

PREZES ZARZĄDU

Arkadiusz Noworyta

Arkadiusz Noworyta

AHPL Generaldirektor

17.2 Spare parts list

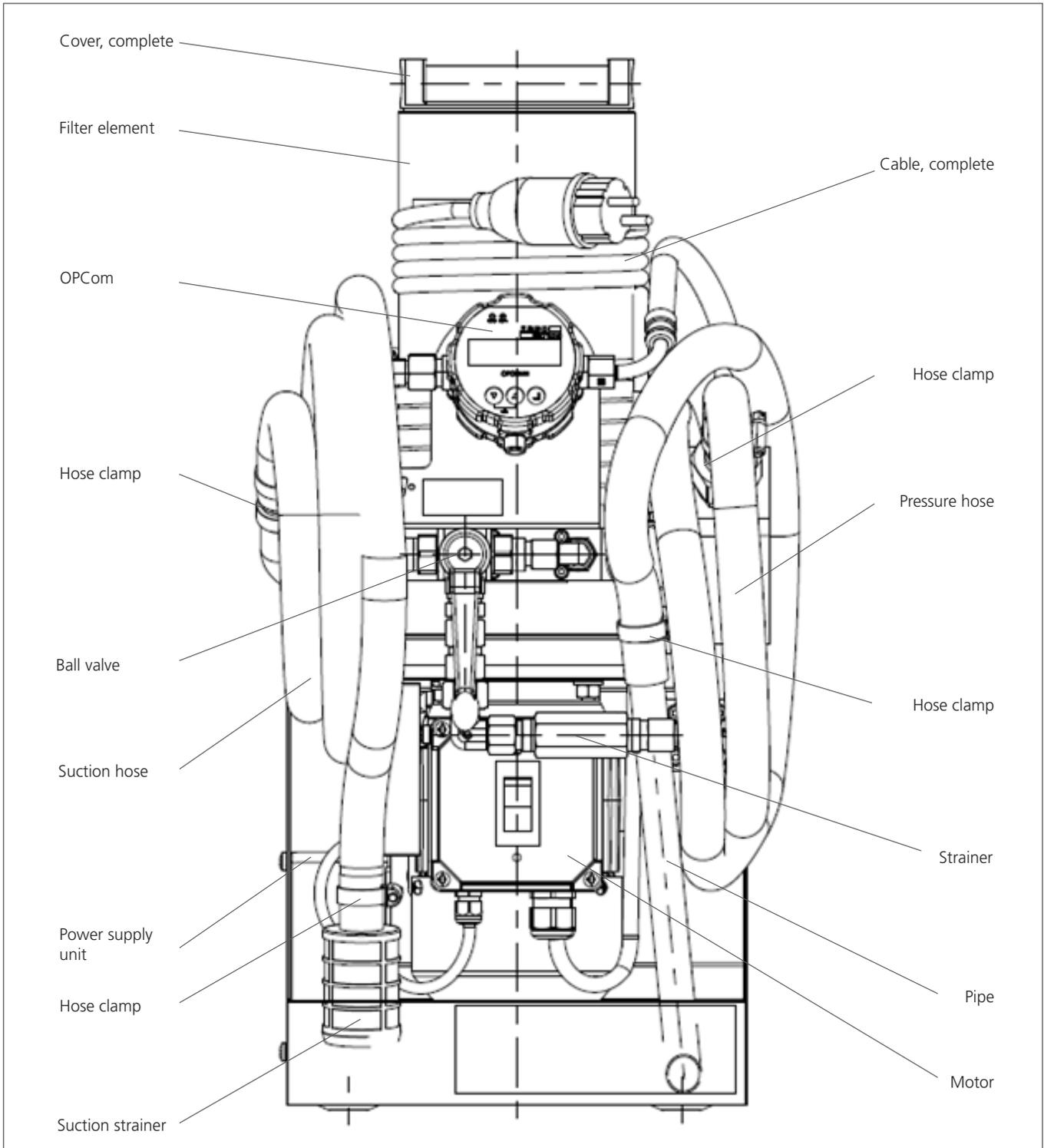

Fig. 18: Spare parts drawing 1

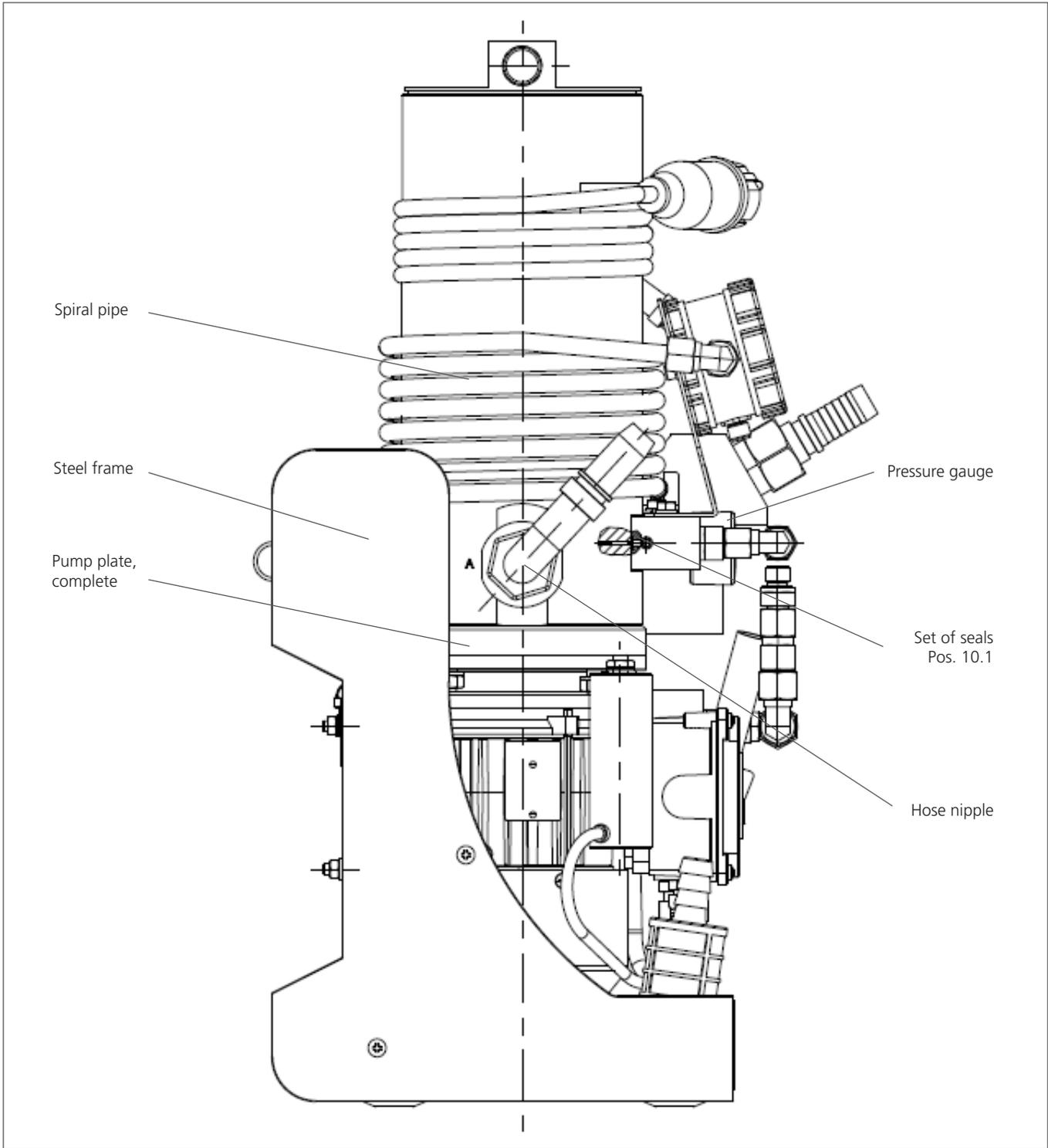

Fig. 19: Spare parts drawing 2

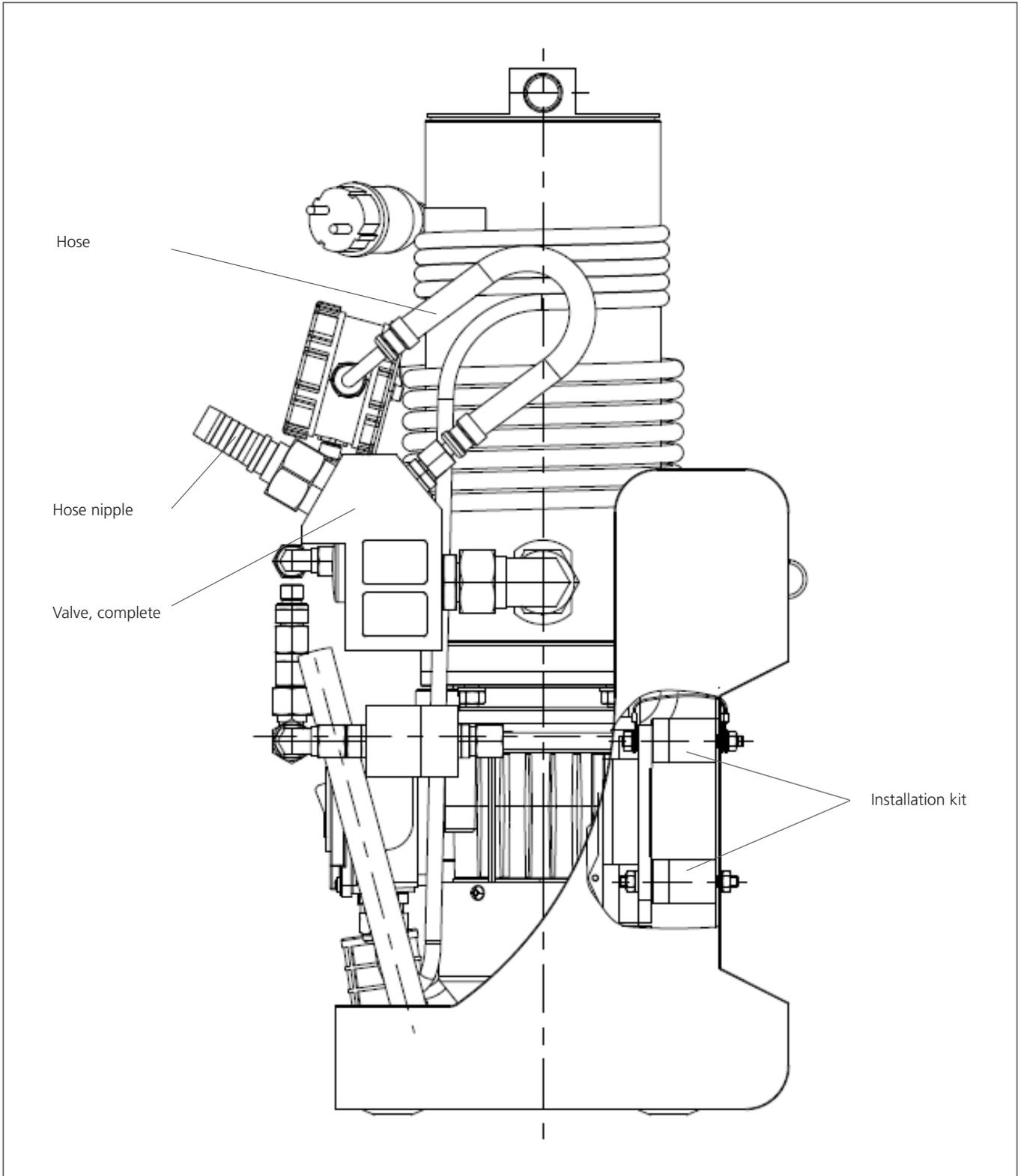

Fig. 20: Spare parts drawing 3

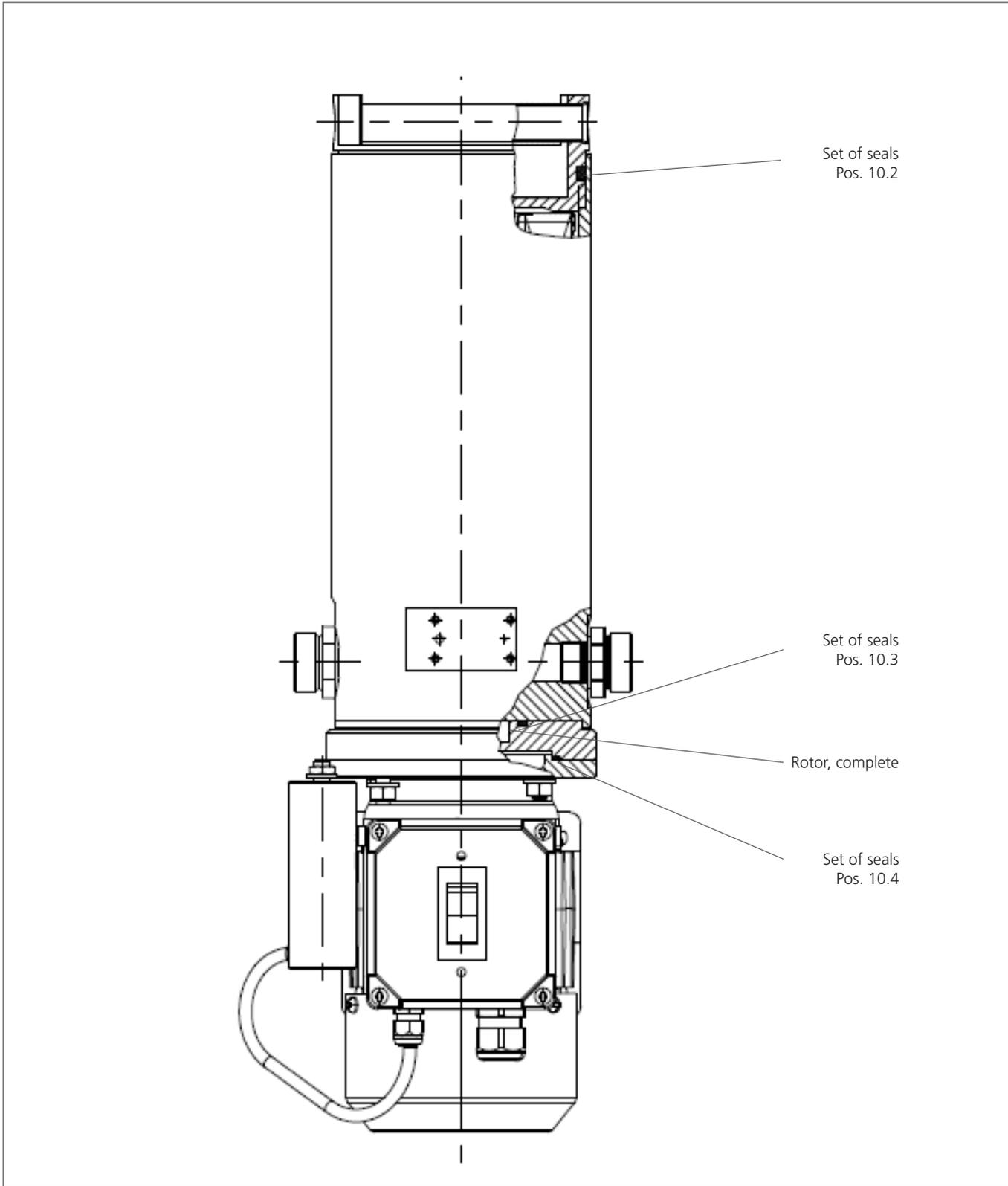

Fig. 21: Spare parts drawing 4

Pos.	Designation	Pieces	Order No.	Remark
1	Filter element	1	V7.1220-113 14311300	
2	Strainer	1	S9.0205-02 1507740	
3	Pressure gauge	1	DG 200-17 14229800	
4	Ball valve G¼"	1	FA 016.0725 14218300	
5	Cover, complete.	1	FNA 008.1205 34272300	
6	Pump plate, complete	1	FNA 008.1230 13376300	consisting of pump plate, outer rotor and inner rotor
7	Rotor, complete	1	FNA 008.1730 15110300	consisting of outer rotor and inner rotor
8	Steel frame	1	FA 016.0101 28500100	
9	Spiral pipe	1	FAPC 016.0713 34444700	
10	Set of seals	1	FAPC 016.1720 15110200	consisting of positions 10.1 to 10.4
11	Valve, complete	1	FAPC 016.1710 15110100	consisting of valve and valve housing
Spare parts OPCom				
12	OPCom	1	SPCO 300-1000 27395401	
13	Hose	1	FA 016.0735 o.Z. 14219700	
14	Power supply unit	1	30881300	
Spare parts motor				
15	Motor	1	FA 016.1700 33589800	for FAPC 016-12105/ 34292600
16	Cable, complete	1	FA 016.1201 11919900	consisting of cable and plug for FAPC 016-12105/ 34292600
17	Installation kit	1	FA 016.1790 17805800	consisting of screws, nuts, rubber buffers and spacer
Spare parts pressure hose				
18	Pipe	1	FA 016.0103 13448700	
19	Hose clamp	4	DIN 3017 11889400	
20	Pressure hose	1	FA 016.0107 11905300	
21	Hose nipple	1	FA 016.0736 14219800	
Spare parts suction hose				
22	Suction strainer	1	FA 016.0301S7 33225200	
23	Suction hose	1	FA 016.0106 11904900	
24	Hose nipple	1	FA 016.1401 11887400	

Table 8: Spare parts list

International

ARGO-HYTOS worldwide

Benelux	ARGO-HYTOS B.V.	info.benelux@argo-hytos.com
Brazil	ARGO-HYTOS Fluid Power Systems Ltda.	info.br@argo-hytos.com
China	ARGO-HYTOS Fluid Power Systems	info.cn@argo-hytos.com
Czech Republic	ARGO-HYTOS s.r.o	info.cz@argo-hytos.com
	ARGO-HYTOS Protech s.r.o	info.protech@argo-hytos.com
France	ARGO-HYTOS SAS	info.fr@argo-hytos.com
Germany	ARGO-HYTOS GMBH	info.de@argo-hytos.com
Great Britain	ARGO-HYTOS Ltd.	info.uk@argo-hytos.com
Hong Kong	ARGO-HYTOS Hong Kong Ltd.	info.hk@argo-hytos.com
India	ARGO-HYTOS PVT. LTD.	info.in@argo-hytos.com
Italy	ARGO-HYTOS S.r.l.	info.it@argo-hytos.com
Poland	ARGO-HYTOS Polska spz o.o.	info.pl@argo-hytos.com
Sweden	ARGO-HYTOS Nordic AB	info.se@argo-hytos.com
Turkey	ARGO-HYTOS Hidrolik Ekip. San. ve Tic. Ltd. Şti.	info.tr@argo-hytos.com
USA	ARGO-HYTOS Inc.	info.us@argo-hytos.com

