

Explosion Proof 3/2 Directional Valve, Solenoid Operated, Spool Type, Direct Acting

SD2E2X-B3

7/8-14 UNF • Q_{max} 60 l/min (16 GPM) • p_{max} 350 bar (5100 PSI)



Technical Features

- › 3/2-screw-in cartridge directional control valve, spool type, with 7/8-14 UNF connection thread
- › Maximum operating pressure 350 bar (P, A, B ports) / 210 bar (T port)
- › Certification of solenoid coil ATEX (Directive 2014/34/EU) and IECEx, valid for mines and environments with potentially explosive atmospheres consisting of gases or dust
- › Coil certification "FM APPROVED" valid for USA and Canada
- › Coil protection by flameproof enclosure "d" / "t" (for dust)
- › Robust design resistant to mechanical damage
- › Protection against static discharge by grounding the valve surface
- › Valves applicable for temperature classes T4 (135 °C), T5 (100 °C) and T6 (85 °C) depending on maximum ambient temperature
- › Easily interchangeable direction of power cable entry (axial/radial) into the coil
- › Optional coil supply voltage, valve connection and type of manual override
- › The valve is zinc coated for 520 h corrosion protection in NSS acc. to ISO 9227 and as protection against ignition spark in the event of mechanical impact

Product Description

Screw-in cartridge directional control valve, spool type, direct-operated by solenoid. The valve is designed to control the direction of fluid flow or to dam it. For example, it can control a single-acting cylinder or alternately connect two independent branches of a circuit to a pressurized fluid source. The valve is certified for use in potentially explosive atmospheres of gases, vapors, dusts and combustible particles with a high protection level of EPL = b.

Use of the valve in potentially explosive atmospheres



12 V / 24 V / 48 V / 110 V DC 110 V / 230 V AC 50 / 60 Hz	Zones	Type of protection – flameproof enclosure
Ex I M2 Ex db I Mb	Category Mb	"d" (EN /IEC 60079-1)
Ex II 2G Ex db IIB+H2 T6, T5, T4 Gb	Zones 1, 2	"d" (EN /IEC 60079-1)
Ex II 2D Ex tb IIIC T85°C, T100°C, T135°C Db	Zones 21, 22	"t" (EN/IEC 60079-31)



NEC 500 (USA), Annex J (Canada)	NEC 505, 506 (USA)	CEC Section 18 (Canada)
Class I Division 1 Group B, C, D T6 ... T4 Class II / III Division 1 Group E, F, G T6 ... T4	CL I Zone 1, AEx db IIB+H2, T6 ... T4 Gb Zone 21, AEx tb IIIC T85°C ... T135°C Db	Ex db IIB+H2 T6 ... T4 Gb Ex tb IIIC T85°C ... T135°C Db

Characteristics measured at v = 32 mm²/s (156 SUS)

Operating limits (p-Q)

Ambient temperature 70 °C (158 °F), Voltage U_n -10 % (24 V DC), Power P_n 10 W

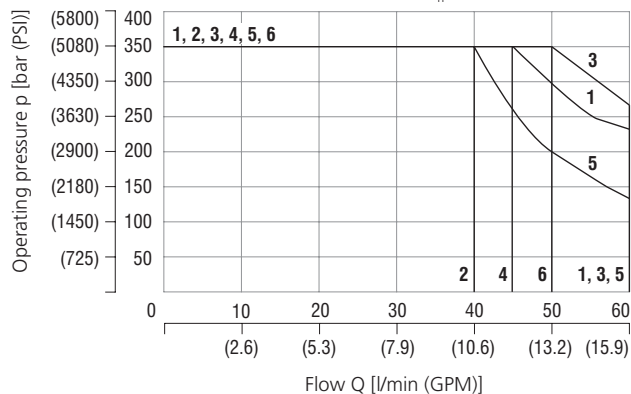

	Model	Direction	Model	Direction	
1	2D21	3→2	4	2D25	2→1
2	2D21	2→1	5	2D26	3→2
3	2D25	3→2	6	2D26	2→1

Pressure drop related to flow rate (Δp-Q)

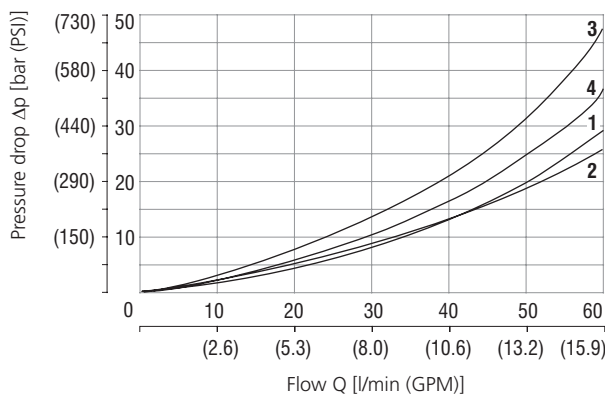

	Model	Direction	Model	Direction	
1	2D21	2→1	1	2D26	3→2
2	2D21	3→2	1	2D26	2→1
3	2D25	3→2	4	2D25	2→1

For operating limits under conditions other than shown contact the technical support.

Technical Data

Valve size / Cartridge cavity		7/8-14 UNF-2A / B3 (C-10-3)	
Max. flow	l/min (GPM)	60 (15.9)	
Max. operating pressure	bar (PSI)	350 (5080)	
Fluid temperature range (NBR)	°C (°F)	-30 ... +70 (-22 ... +158)	
Max. switching frequency	1/h	15 000	
Weight with coil	kg (lbs)	1.81 (3.99)	
Technical Data - Explosion proof solenoid			
Voltage type		AC 50 / 60 Hz	DC
Available nominal voltages U _N	V	110, 230	12, 24, 48, 110
Available nominal input power	W	10	
Supply voltage fluctuations		U _N ± 10 %	
Duty cycle		S1(100 % ED)	
Enclosure type acc. to EN 60529		IP66 / IP68*	
Test procedure IP68: Pressure 1 m under water, test duration 24 h. The indicated IP protection level is only achieved if the cable is properly mounted.			
Weight (coil only)	kg (lbs)	1.49 (3.29)	
Ambient temperature range			
Temperature class / Nominal power	T4-10 W	°C (°F)	-30 ... +70 (-22 ... +158)
	T5-10 W		-30 ... +55 (-22 ... +131)
	T6-10 W		-30 ... +40 (-22 ... +104)
		Datasheet	Type
General information	GI_0060	Products and operating conditions	
Operating instructions	15322		
Valve bodies	In-line mounted	SB_0018	SB-B3*
	Sandwich mounted	SB-04(06)_0028	SB-*B3*
Cavity details / Form tools	SMT_0019	SMT-B3*	
Spare parts	SP_8010		

Ordering Code

SD2E2X - B3 / H [] / [] [] **A6** [] [] - **B** []

Explosion proof 3/2 directional valve, solenoid operated, spool type direct acting

Valve cavity
7/8-14 UNF (C-10-3)

Model
High performance

Model / Symbol

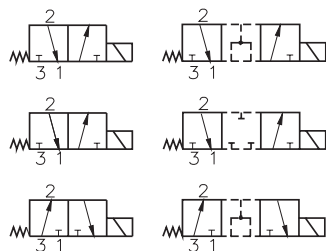

Rated supply voltage of solenoids

DC voltage (I_N)	
12 V DC / 0.75 A	01200
24 V DC / 0.39 A	02400
48 V DC / 0.19 A	04800
110 V DC / 0.086 A	11000

AC voltage 50/60 Hz (I_N)	
110 V AC / 0.084 A	11050
230 V AC / 0.046 A	23050

Certifications of valve
No designation ATEX, IECEx, UKCA, FM APPROVED

Surface treatment
520 h salt spray test (ISO 9227)

Seals
No designation NBR, polyurethane

Manual override
No designation standard
N7 detent assembly
N9 without manual override

Temperature class - solenoid nominal input power
Class T4, T5, T6 - 10 W

Threaded adapter with thread
M M20x1.5
NPT ½ NPT ANSI

Manual Override measured in millimeters (in)

No designation - standard	N7 - detent assembly	N9 - without manual override

In case of solenoid malfunction or power failure, the valve spool can be shifted by manual override under the condition that the pressure in the back line does not exceed 25 bar (363 PSI).

Dimensions in millimeters (in)

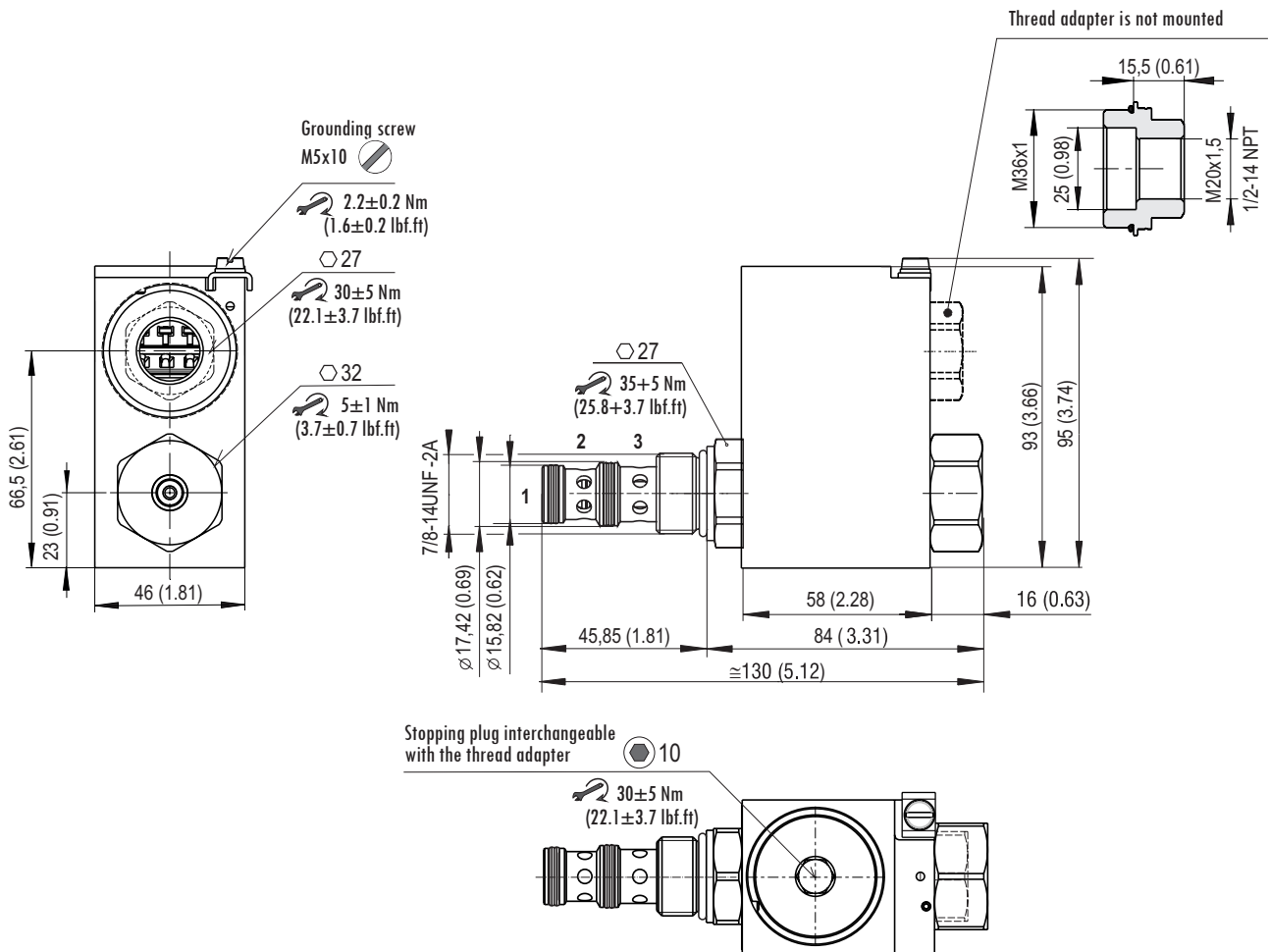

Ordering

The access to the terminal is covered by a steel plug with a seal, mounted on the upper surface of the coil casing. A second hole in the casing is provided for a thread adapter with an optional M20x1.5 (M key) or 1/2 NPT ANSI (NPT key) thread. The thread adapter with a seal is included because the design of the coil casing allows the axial input of the power cable to be easily changed to vertical by interchanging the plug and thread adapter.

SPARE PARTS

Position	Component name	Description	Ordering number
1A	Thread adapter with the thread M20x1.5	Set with the sealing ring 36x2 VQM (silicone)	44915100
1B	Thread adapter with the tapered thread ½ NPT ANSI	Set with the sealing ring 36x2 VQM (silicone)	44915000
2	Coil nut	Nut	44915200
4	Set Sealing ring actuating system-coil	O-ring 22x1.5 VMQ 50 (silicone)	
	Nut sealing	O-ring 21.89x2.62 VMQ 70 (silicone)	
3	Coil nut with manual override N7	Nut	45904200
4	Set Sealing ring actuating system-coil	O-ring 22x1.5 VMQ 50 (silicone)	
	Nut sealing	O-ring 21.89x2.62 VMQ 70 (silicone)	
5	Stopping plug	Set with the sealing ring 36x2 VQM (silicone)	44923800
6	Set Bush sealing	SP-SK-B3-N O-ring 19.4x2.1 NBR Dualseal 15.07x17.47x3.1 PU Dualseal 13.47x15.87x3.1 PU	18960700

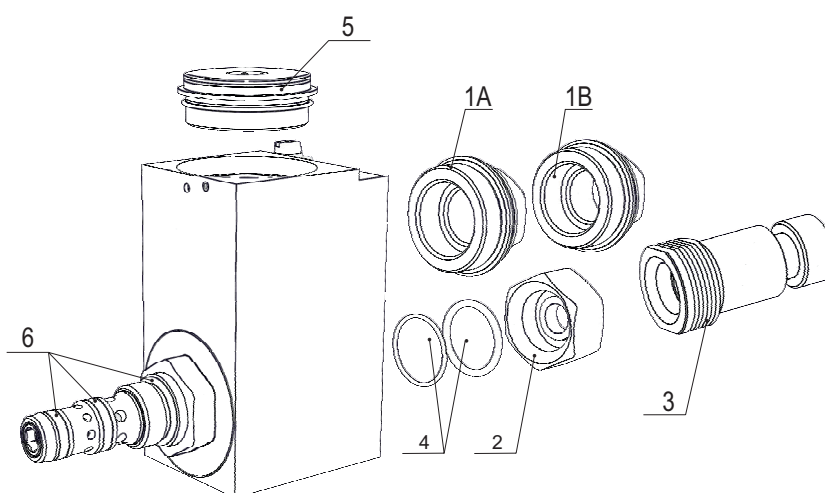
Information for customers

- › Before installing the product, please read the Product Instructions for Use, which is available in full on the manufacturer's website (www.argo-hytos.com) near the data sheet. Please also pay attention to the chapter describing the target user group, their professional qualifications and medical fitness to install, use and repair the product.
- › The product may only be used in the zones indicated, otherwise there is a risk of initiating an explosion

Area of application

Equipment - group I – MINES	Equipment - group II (IIG) - GAS		Equipment - group III (IID) - DUST	
Category M1 – NO	Zone 0 - NO		Zone 20 - NO	
Category M2 (the device remains switched off)	Zone 1 Zone 2	IIA (propane)	Zone 21 Zone 22	IIIA (combustible particles)
		II B (ethylene) + H ₂		IIIB (non-conductive dust)
				IIIC (conductive dust)

Note: The valve may be used in potentially explosive hydrogen atmospheres belonging to Group IIC. However, it cannot be used for other Group IIC gases, e.g. acetylene

- › For use in the temperature class, the maximum ambient temperature (see technical data table) must be observed for a given coil input (10 W), the maximum temperature of the working fluid 70 °C and the nominal voltage of the coil supply.
- › The user must ensure free heat dissipation from the valve surface. The surface must not be covered, exposed to a heat source or direct sunlight. When mounting the valves in groups, observe the minimum distances specified in the Instructions for Use.
- › Use a certified cable and a cable gland with protection "d" to prevent the penetration of hot gases into the surrounding environment when an explosion is initiated in the interior of the flameproof enclosure. The insulation must match the temperature class.
- › It is forbidden to install, dismantle or repair the product in an explosive atmosphere. Repairs to the product shall be carried out by the manufacturer, except for repairs permitted by the user under the conditions specified in the Instructions for Use.
- › Attention! The surface of the coil and the valve heats up during operation. There is a risk of skin burns if touched.