

Explosion Proof Proportional Directional Control Valve, Pilot Operated

PRM2X8-06

Size 06 (D03) • Q_{max} 140 l/min (37 GPM) • p_{max} 350 bar (5100 PSI)

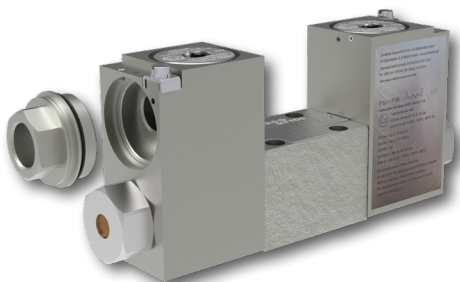

Technical Features

- Hydraulic, proportional, spool-type, directional control valve with cast iron body and connection according to ISO 4401 and DIN 24340 (CETOP 03)
- Maximum operating pressure 350 bar (P, A, B ports) / 210 bar (T port)
- Transmitted high hydraulic power
- Solenoid coil certification ATEX (Directive 2014/34/EU) and IECEx, valid for mines and environments with potentially explosive atmospheres consisting of gases or dust
- Coil certification "FM APPROVED" valid for USA and Canada
- Coil protection by flameproof enclosure "d" / "t" (for dust)
- Robust design resistant to mechanical damage
- Protection against static discharge by grounding the valve surface
- Valves applicable to temperature class T4 (135 °C) depending on maximum ambient temperature
- Easily interchangeable direction of power cable entry (axial/radial) into the coil
- Optional coil supply voltage, spool type and type of manual override
- The valve is zinc coated for 520 h corrosion protection in NSS acc. to ISO 9227 and as protection against ignition spark in the event of mechanical impact

Product Description

Pilot operated, proportional, spool-type directional control valve operated by solenoids. The valve is designed for continuous control of volumetric flow, proportional to the control electrical signal. In practice, the valve is used to continuously control the speed and direction of the hydraulic cylinder piston rod or hydraulic motor shaft speed. A suitable electronic control unit (not supplied) should be used to control the valve, which must meet the necessary degree of protection or be located outside an explosive atmosphere. The valve is certified for use in potentially explosive atmospheres of gases, vapors, dust and flammable particles with a high protection level EPL = b.

Use of the valve in potentially explosive atmospheres



12 V / 24 V / 48 V / 110 V DC 110 V / 230 V AC 50 / 60 Hz	Zones	Type of protection – flameproof enclosure
Ex I M2 Ex db I Mb	Category Mb	"d" (EN /IEC 60079-1)
Ex II 2G Ex db IIB+H2 T4 Gb	Zones 1, 2	"d" (EN /IEC 60079-1)
Ex II 2D Ex tb IIIC T135°C Db	Zones 21, 22	"t" (EN/IEC 60079-31)



NEC 500 (USA), Annex J (Canada)

Class I Division 1 Group B, C, D T4
Class II / III Division 1 Group E, F, G T4

NEC 505, 506 (USA)

CL I Zone 1, AEx db IIB+H2, T4 Gb
Zone 21, AEx tb IIIC T135°C Db

CEC Section 18 (Canada)

Ex db IIB+H2 T4 Gb
Ex tb IIIC T135°C Db

ISO 4401-03-02-0-05

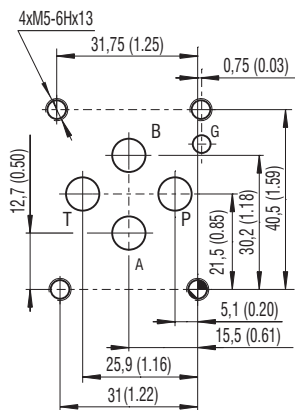

Ports P, A, B, T max. \varnothing 7.5 mm (0.29 in)

Characteristics measured at $v = 32 \text{ mm}^2/\text{s}$ (156 SUS)

Operating limits:

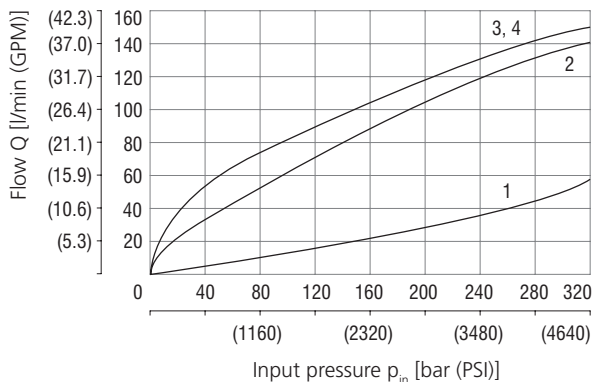

ξ [%]	1	2	3	4
	40	60	80	100

Characteristics measured at $v = 32 \text{ mm}^2/\text{s}$ (156 SUS)

Flow characteristics:

$\Delta p = 10 \text{ bar}$ (145 PSI) Flow direction $P \rightarrow A / B \rightarrow T$ or $P \rightarrow B / A \rightarrow T$

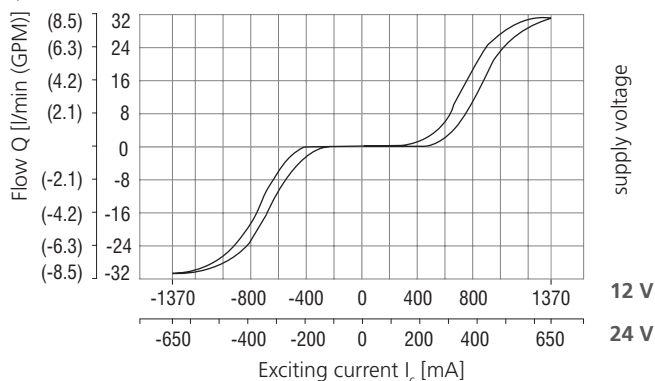

Flow characteristic:

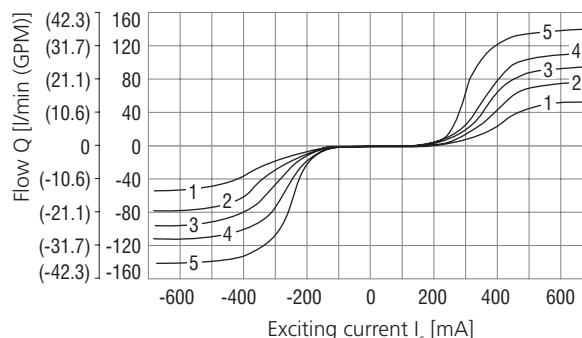

p_{in} [bar (PSI)]	1	2	3	4	5
	50 (725)	100 (1450)	150 (2180)	200 (2900)	320 (4640)

Ordering Code

PRM2X8-06 / 25 - B4 - 1 B

Explosion proof
Proportional directional
control valve, pilot operated

Valve size

Spool symbols

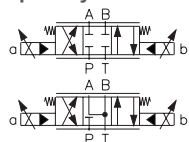

Nominal flow rate at $\Delta p = 10 \text{ bar}$ (145 PSI)
25 l/min (6.6 GPM)

Supply voltage / limit current (I_G)
12 V DC / 1.32 A
24 V DC / 0.64 A

12
24

M
NPT

Certifications of valve
No designation ATEX, IECEx,
UKCA, FM APPROVED

Surface treatment
520 h salt spray test (ISO 9227)

Clamping length for mounting screw
22 mm (0.86 in)

Seals
No designation NBR

Manual override
No designation standard
N7 detent assembly

Temperature class - solenoid nominal input power
Class T4 - 18 W

Threaded adapter with thread
M20x1.5
1/2 NPT ANSI

- For proportional valves with two solenoids, one solenoid must be de-energized before the other solenoid can be charged.
- Mounting bolts M5x30 DIN 912-10.9 or studs must be ordered separately. Tightening torque is 8.9 Nm (6.56 lbf.ft).

Technical Data

Valve size		06 (D03)
Max. operating pressure at ports P, A a B	bar (PSI)	350 (5080)
Max. flow at pressure 320 bar (4640 PSI)	l/min (GPM)	140 (37)
Max. operating pressure at port T	bar (PSI)	210 (3050)
Fluid temperature range (NBR)	°C (°F)	-30 ... +70 (-22 ... +158)
Ambient temperature max.	°C (°F)	-30 ... +60 (-22 ... +140)
Nominal flow rate Q_n at $\Delta p=10 \text{ bar}$ (145 PSI)	l/min (GPM)	25 (6.6)
Hysteresis	%	< 6
Weight	valve with 1 solenoid	2.56 (5.64)
	valve with 2 solenoids	4.06 (8.95)
Technical Data - Explosion proof solenoid		
Available nominal voltages U_N	V DC	12 24
Available nominal input power	W	18
Supply voltage fluctuations		$U_N \pm 10 \%$
Enclosure type acc. to EN 60529		IP66 / IP68*
* Test procedure IP68: Pressure 1 m under water, test duration 24 h. The indicated IP protection level is only achieved if the cable is properly mounted.		
Limit current	A	1.32 0.64
Rated resistance at 20 °C (68 °F)	Ω	7.6 31.2
		Datasheet Type
General information	GI_0060	products and operating conditions
Operating instructions	15314	
Mounting surface	SMT_0019	Size 06
Spare parts	SP_8010	

Manual Override measured at millimeters (in)

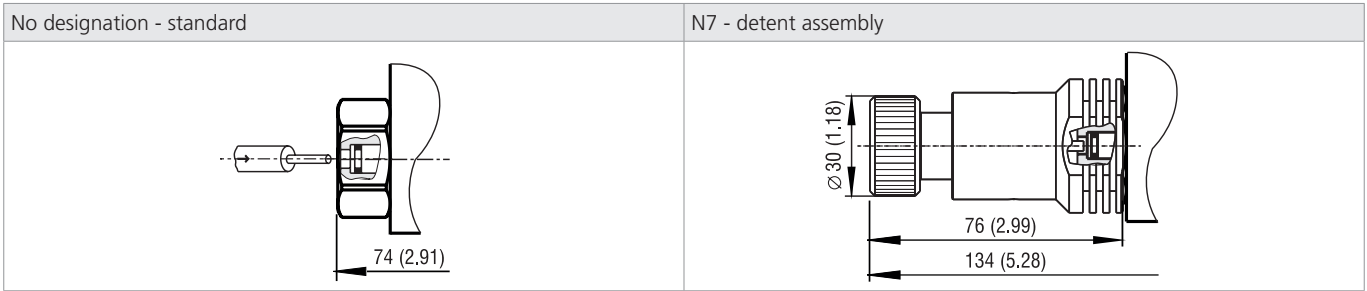

In case of solenoid malfunction or power failure, the valve spool can be shifted by manual override under the condition that the pressure in the back line does not exceed 25 bar (363 PSI).

Dimensions in millimeters (in)

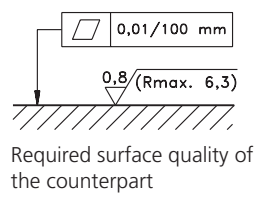
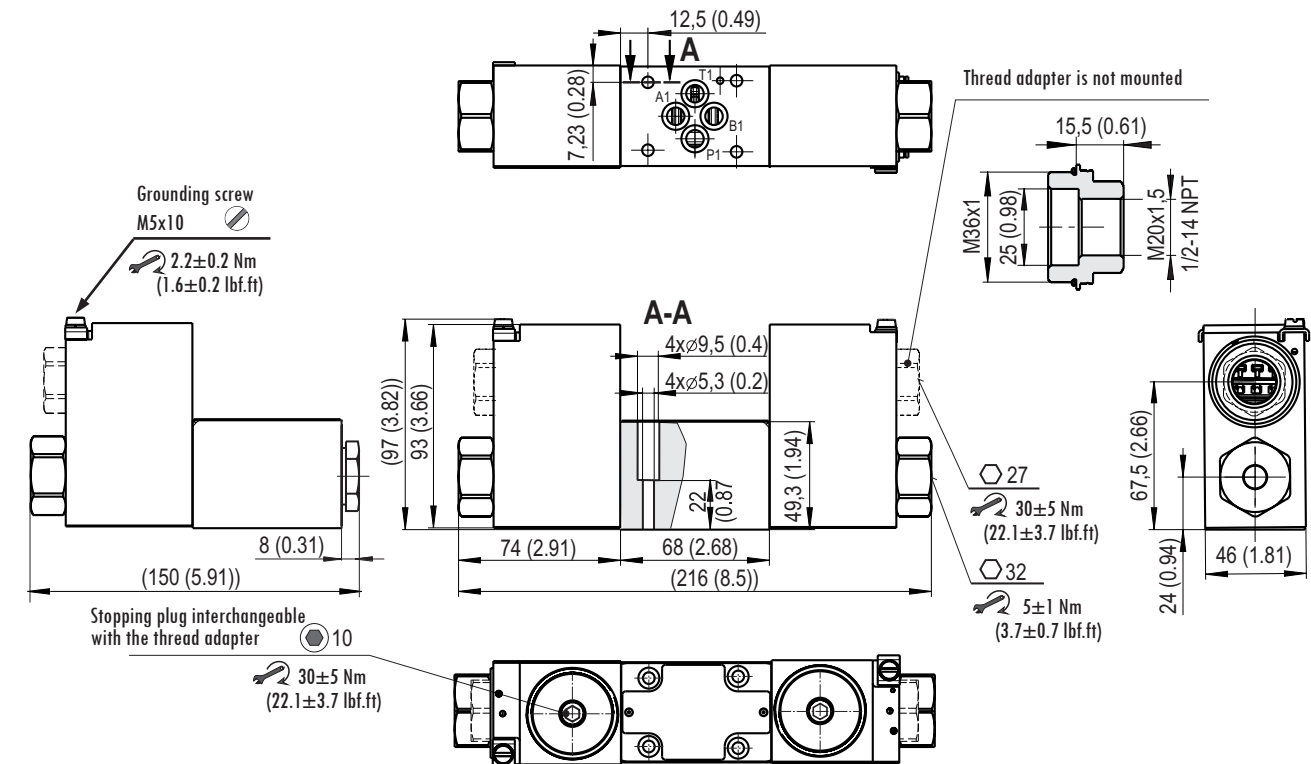

Ordering

The access to the terminal is covered by a steel plug with a seal, mounted on the upper surface of the coil casing. A second hole in the casing is provided for a thread adapter with an optional M20x1.5 (M key) or 1/2 NPT ANSI (NPT key) thread. The thread adapter with a seal is included because the design of the coil casing allows the axial input of the power cable to be easily changed to vertical by interchanging the plug and thread adapter.

SPARE PARTS

Position	Component name	Description	Ordering number
1A	Thread adapter with the thread M20x1.5	Set with the sealing ring 36x2 VQM (silicone)	44915100
1B	Thread adapter with the tapered thread ½ NPT ANSI	Set with the sealing ring 36x2 VQM (silicone)	44915000
2	Coil nut	Nut	44915200
4	Set Sealing ring actuating system-coil	O-ring 22x1.5 VMQ 50 (silicone)	
	Nut sealing	O-ring 21.89x2.62 VMQ 70 (silicone)	
3	Coil nut with manual override N7	Nut	45904200
4	Set Sealing ring actuating system-coil	O-ring 22x1.5 VMQ 50 (silicone)	
	Nut sealing	O-ring 21.89x2.62 VMQ 70 (silicone)	
5	Stopping plug	Set with the sealing ring 36x2 VQM (silicone)	44923800
6	Set of seals	4x Square ring 9.25x1.68 NBR	15845200
7	Set	Valve mounting screws	40101700

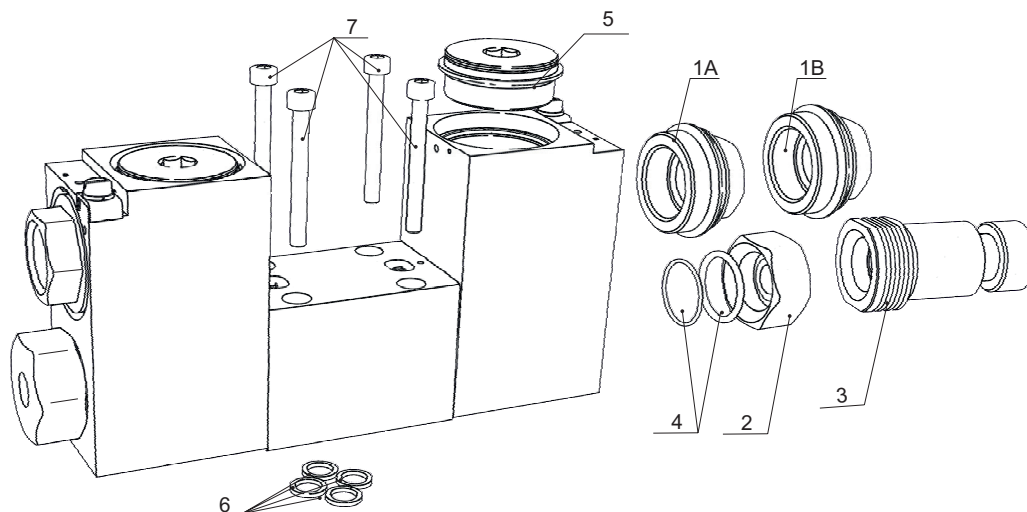

Information for customers

- › Before installing the product, please read the Product Instructions for Use, which is available in full on the manufacturer's website (www.argo-hytos.com) near the data sheet. Please also pay attention to the chapter describing the target user group, their professional qualifications and medical fitness to install, use and repair the product.
- › The product may only be used in the zones indicated, otherwise there is a risk of initiating an explosion

Area of application

Equipment - group I – MINES	Equipment - group II (IIG) - GAS		Equipment - group III (IID) - DUST	
Category M1 – NO	Zone 0 - NO		Zone 20 - NO	
Category M2 (the device remains switched off)	Zone 1	IIA (propane)	Zone 21	IIIA (combustible particles)
		IIB (ethylene) + H2		IIIB (non-conductive dust)
	Zone 2		Zone 22	IIIC (conductive dust)

Note: The valve may be used in potentially explosive hydrogen atmospheres belonging to Group IIC. However, it cannot be used for other Group IIC gases, e.g. acetylene

- › For use in the temperature class, the maximum ambient temperature (see technical data table) must be observed for a given coil input (18 W), the maximum temperature of the working fluid 70 °C and the nominal voltage of the coil supply. The 18 W coil valve may only be used in temperature class T4 (135 °C).
- › The user must ensure free heat dissipation from the valve surface. The surface must not be covered, exposed to a heat source or direct sunlight. When mounting the valves in groups, observe the minimum distances specified in the Instructions for Use.
- › Use a certified cable and a cable gland with protection "d" to prevent the penetration of hot gases into the surrounding environment when an explosion is initiated in the interior of the flameproof enclosure. The insulation must match the temperature class.
- › It is forbidden to install, dismantle or repair the product in an explosive atmosphere. Repairs to the product shall be carried out by the manufacturer, except for repairs permitted by the user under the conditions specified in the Instructions for Use.
- › Attention! The surface of the coil and the valve heats up during operation. There is a risk of skin burns if touched.