

High Pressure Filters – Worldline 400

HD 790 · HD 990

In-line mounting · Operating pressure up to 630 bar / 9137 psi · Nominal flow rate up to 1.000 l/min / 264.2 gpm



High Pressure Filter HD 990

Description

Application

In the high pressure circuits of hydraulic systems.

Performance features

Protection against wear:

By means of filter elements that even in full-flow filtration meet the highest demands regarding cleanliness classes.

Protection against malfunction:

Through installation near to the control valves or other expensive components. The specific determined flow rate guarantees a closed by-pass valve even at $v \leq 200 \text{ mm}^2/\text{s}$ / 927 SUS (cold start condition).

Filter elements

Flow direction from outside to center.

The star-shaped pleating of the filter material results in:

- › large filter surfaces
- › low pressure drop
- › high dirt-holding capacities
- › long service life

Filter maintenance

By using a clogging indicator the correct moment for maintenance is stated and guarantees the optimum utilization of the filter life.

Materials

Filter head:	Spheroidal graphite cast iron (SGI)
Filter bowl:	Steel
Housing cover:	Spheroidal graphite cast iron (SGI)
Coating:	Powder paint
Seals:	NBR (FPM on request)
Filter media:	EXAPOR®MAX 3 – inorganic multi-layer microfiber web

Accessories

Electrical and / or optical clogging indicators are available – optionally with one or two switching points resp. temperature suppression.

Dimensions and technical data see catalog sheet 60.30.

Operating pressure

0 ... 400 bar / 5800 psi, min. 2×10^6 pressure cycles
Nominal pressure according to DIN 24550

0 ... 630 bar / 9137 psi, min. 10^4 pressure cycles
Quasi-static operating pressure

Permissible pressures for other numbers of cycles

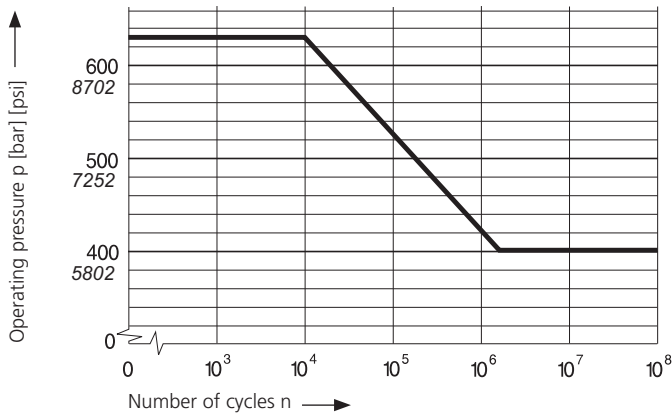

Nominal flow rate

Up to 1000 l/min / 264.2 gpm (see Selection Chart, column 2)
The nominal flow rates indicated by ARGO-HYTOS are based on the following features:

- › closed by-pass valve at $v \leq 200 \text{ mm}^2/\text{s}$ / 927 SUS
- › element service life > 1000 operating hours at an average fluid contamination of 0.07 g per l/min / 0.27 g per gpm flow volume
- › flow velocity in the connection lines:
up to 250 bar $\leq 8 \text{ m/s}$ / up to 3626 psi $\leq 26.3 \text{ ft/s}$
> 250 bar $\leq 12 \text{ m/s}$ / > 3626 psi $\leq 39.4 \text{ ft/s}$

Filter fineness

5 $\mu\text{m(c)}$... 16 $\mu\text{m(c)}$
 β -values according to ISO 16889
(see Selection Chart, column 4 and diagram Dx).

Dirt-holding capacity

Values in g test dust ISO MTD according to ISO 16889
(see Selection Chart, column 5).

Hydraulic fluids

Mineral oil and biodegradable fluids
(HEES and HETG, see info-sheet 00.20).

Temperature range

-30 °C ... +100 °C (temporary -40 °C ... +120 °C)
-22 °F ... +212 °F (temporary -40 °F ... +248 °F)

Viscosity at nominal flow rate

- › at operating temperature: $v < 60 \text{ mm}^2/\text{s}$ / 280 SUS
- › as starting viscosity: $v_{\text{max}} = 1200 \text{ mm}^2/\text{s}$ / 5560 SUS
- › at initial operation:
The recommended starting viscosity can be read from the diagram D (pressure drop as a function of the kinematic viscosity) as follows: Find the 70% Δp of the cracking pressure of the by-pass valve on the vertical axis. Draw a horizontal line so that it intersects the Δp curve at a point. Read this point on the horizontal axis for the viscosity.

Mounting position

Preferably vertical. The filter head can be mounted in either the uppermost position or the inverse as required.

Connection

- › SAE-flange (6000 psi).
- Sizes see Selection Chart, column 6
(other connections on request).

For installation recommendations, see info sheet 00.325.

Δp-curves for complete filters in Selection Chart, column 3

D1 Pressure drop as a function of the **flow volume** at $v = 35 \text{ mm}^2/\text{s} / 162 \text{ SUS}$ (0 = casing empty)

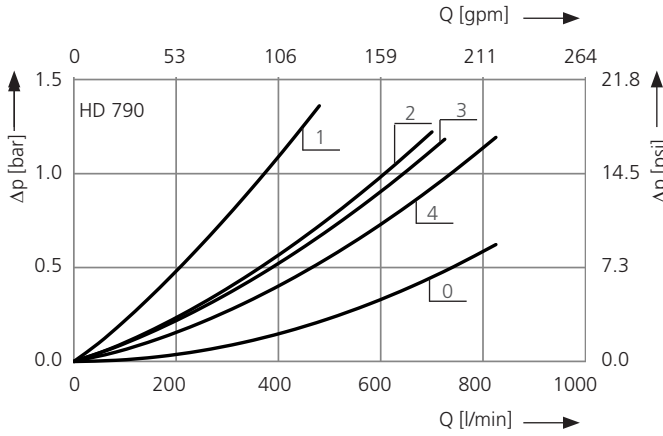

Pressure drop as a function of the **kinematic viscosity** at nominal flow

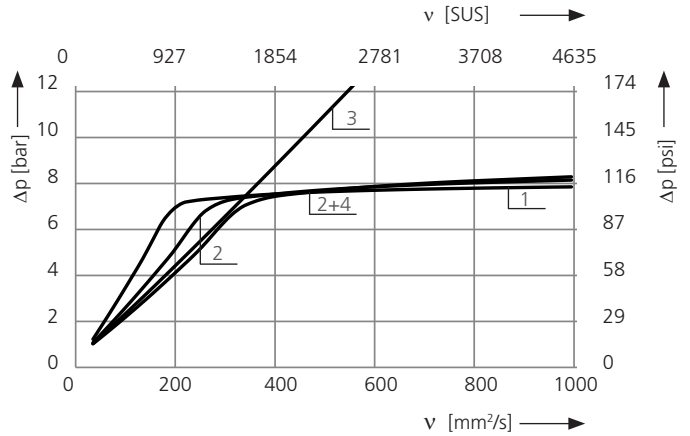

D2 Druckverlust in Abhängigkeit vom **Volumenstrom** bei $v = 35 \text{ mm}^2/\text{s} / 162 \text{ SUS}$ (0 = Gehäuse leer)

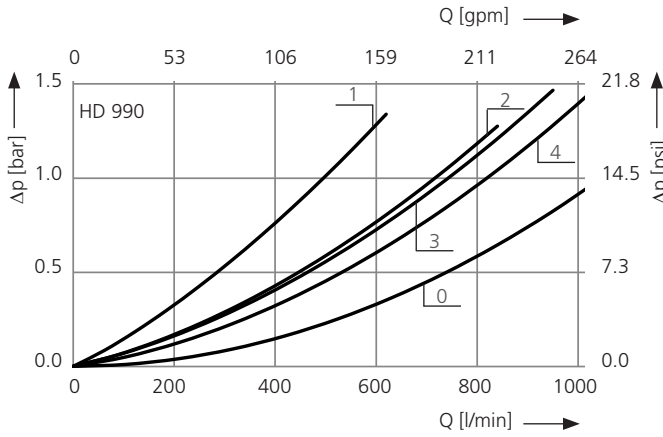

Druckverlust in Abhängigkeit von der **kin. Viskosität** bei Nennvolumenstrom

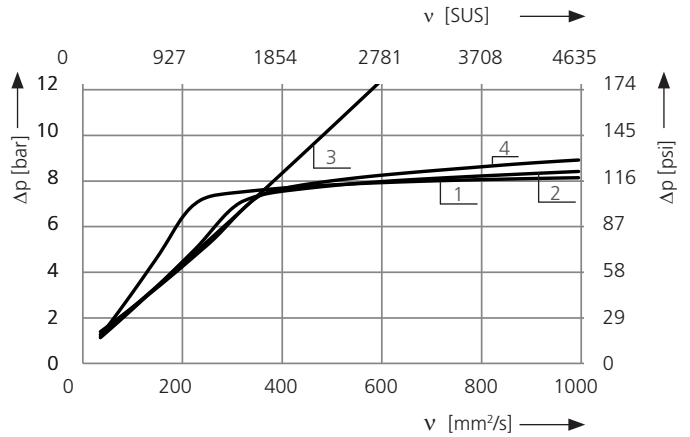

Filter fineness curves in Selection Chart, column 4

Dx Filtration ratio β as a function of particle size x obtained by the Multi-Pass-Test according to ISO 16889

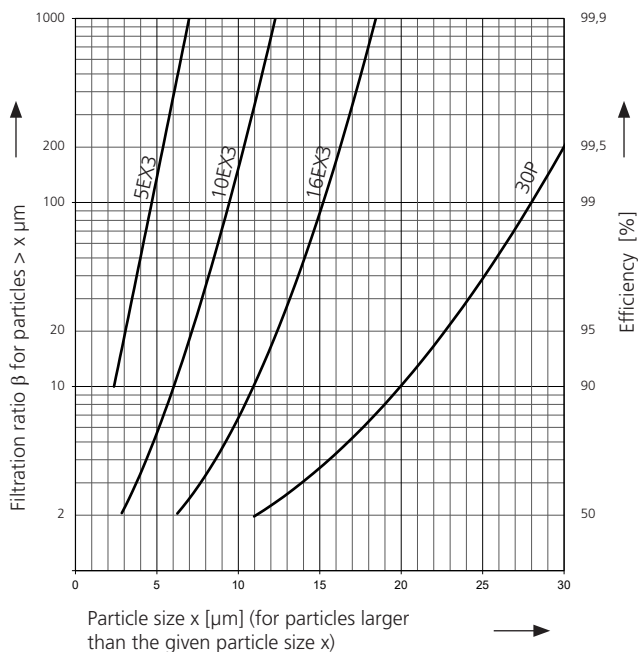

The abbreviations represent the following β -values resp. finenesses:

For EXAPOR®MAX 3 and Paper elements:

- 5EX3 = $\beta_{5(c)} = 200$ EXAPOR®MAX 3
- 10EX3 = $\beta_{10(c)} = 200$ EXAPOR®MAX 3
- 16EX3 = $\beta_{16(c)} = 200$ EXAPOR®MAX 3
- 30P = $\beta_{30(c)} = 200$ Paper

Based on the structure of the filter media of the 30P paper elements, deviations from the printed curves are quite probable.

For screen elements:

- 40S = screen material with mesh size 40 μm
 - 60S = screen material with mesh size 60 μm
 - 100S = screen material with mesh size 100 μm
- Tolerances for mesh size according to DIN 4189

For special applications, finenesses differing from these curves are also available by using special composed filter media.

Selection Charts

Part No.	Nominal flow rate	Pressure drop see diagram D1 /curve no.	Filter fineness see diagram Dx	Dirt-holding capacity	Connection A/B	Cracking pressure of by-pass	Symbol	Replacement filter element Part No.	Weight	Clogging indicator	Remarks
1	l/min	3	4	g	6	7	8	9	kg	11	12
HD 790-159	440	D1/1	5EX3	93	SAE 2	7	4	V3.1040-03	46	retrofitable	-
HD 790-156	640	D1/2	10EX3	94	SAE 2	7	4	V3.1040-06	46	retrofitable	-
HD 790-188	660	D1/3	16EX3	75	SAE 2	-	7	V3.1040-18*	47	retrofitable	-
HD 790-158	750	D1/4	16EX3	97	SAE 2	7	4	V3.1040-08	46	retrofitable	-
HD 990-159	570	D2/1	5EX3	140	SAE 2	7	4	V3.1060-03	55	retrofitable	-
HD 990-156	780	D2/2	10EX3	140	SAE 2	7	4	V3.1060-06	55	retrofitable	-
HD 990-188	870	D2/3	16EX3	110	SAE 2	-	7	V3.1060-18*	56	retrofitable	-
HD 990-158	1000	D2/4	16EX3	150	SAE 2	7	4	V3.1060-08	55	retrofitable	-

1	gpm	3	4	g	6	7	8	9	lbs	11	12
HD 790-356	169.1	D1/2	10EX3	94	SAE 2	102	4	V3.1040-06	101.4	retrofitable	-
HD 790-388	174.4	D1/3	16EX3	75	SAE 2	-	7	V3.1040-18*	103.6	retrofitable	-
HD 790-358	198.1	D1/4	16EX3	97	SAE 2	102	4	V3.1040-08	101.4	retrofitable	-
HD 990-356	206.1	D2/2	10EX3	140	SAE 2	102	4	V3.1060-06	121.3	retrofitable	-
HD 990-388	229.8	D2/3	16EX3	110	SAE 2	-	7	V3.1060-18*	123.5	retrofitable	-
HD 990-358	264.2	D2/4	16EX3	150	SAE 2	102	4	V3.1060-08	121.3	retrofitable	-

* Element differential pressure stable up to 160 bar / 2320 psi, clogging indicator is obligatory

Order Information

Optical or electrical clogging indicators can be provided for clogging monitoring. When ordering filters with clogging indicator for self-assembly, the abbreviation "M" must be used in the order designation of the clogging indicator. The corresponding installation accessories and installation instructions are included.

Order example: The filter HD 790-156 has to be supplied with optical clogging indicator – response pressure 5.0 bar / 73 psi.

Order code:	HD 790-156	/	DG 042-02 M
1. Part No. (Basic unit)	_____		_____
2. Part No. Clogging indicator	_____		

Suitable clogging indicators can be found in catalog sheet 60.30. These must be ordered separately and fitted by the customer. Installation instructions are enclosed.

Remarks:

- › Filter versions without by-pass valves must always be equipped with a clogging indicator.
- › The filters listed in this chart are standard filters. Other designs available on request.

Dimensions

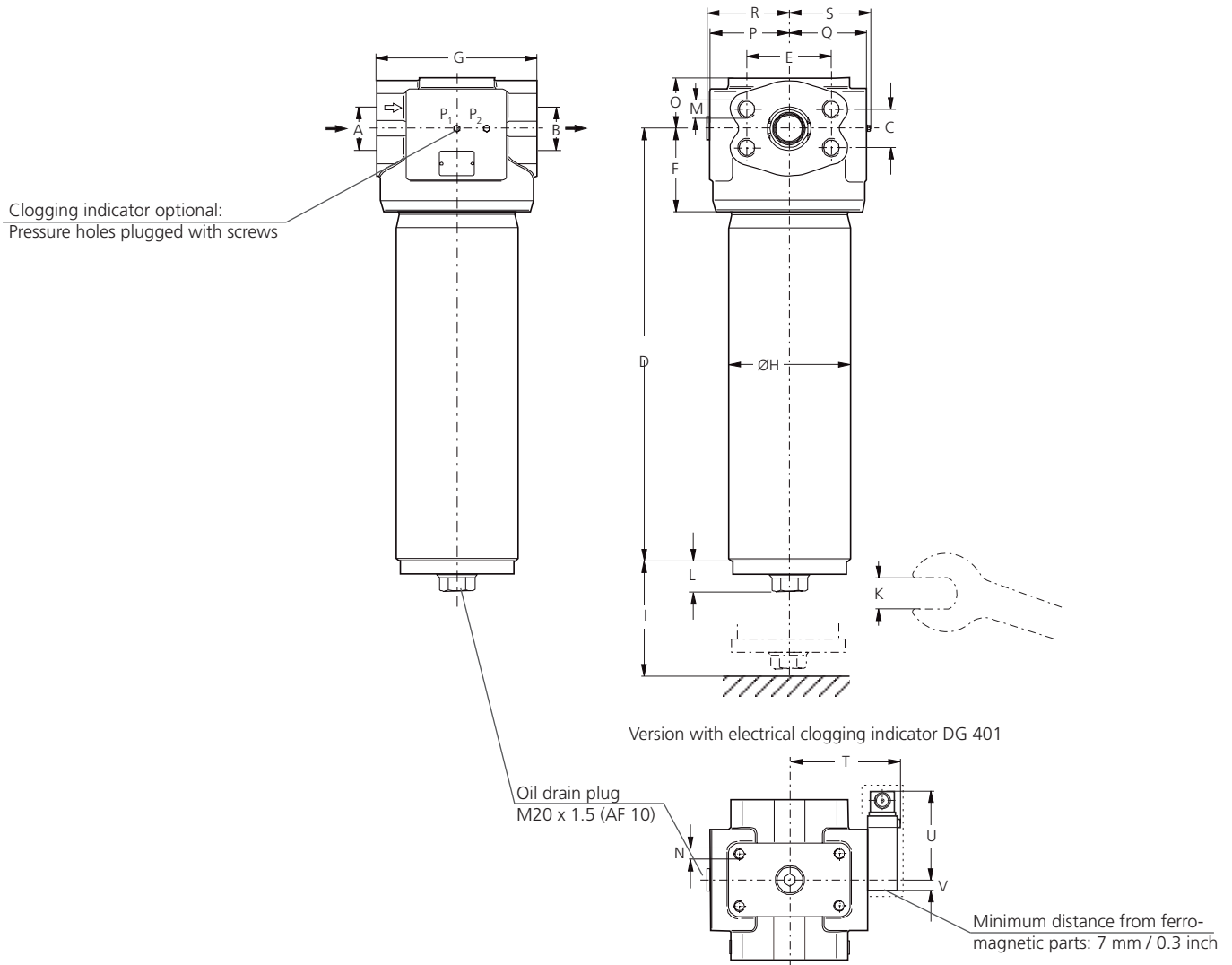

Measurements in mm

Type	A/B	C	D	E	F	G	H	I	K mm	L	M Ø/depth	N Ø/depth	O	P	Q	R
HD 790	SAE 2	44.4	495	96.6	96	184	140	430	AF 36	36	M20 / 32	M12 / 20	58	91	89	95
HD 990	SAE 2	44.4	700	96.6	96	184	140	640	AF 36	36	M20 / 32	M12 / 20	58	91	89	95

Type	S	T	U	V												
HD 790	93	122	102	13												
HD 990	93	122	102	13												

Measurements in inch

Type	A/B	C	D	E	F	G	H	I	K mm	L	M Ø/depth	N Ø/depth	O	P	Q	R
HD 790	SAE 2	1.75	19.49	3.80	3.78	7.24	5.51	16.93	AF 36	1.42	*	**	2.28	3.58	3.50	3.74
HD 990	SAE 2	1.75	27.56	3.80	3.78	7.24	5.51	25.20	AF 36	1.42	*	**	2.28	3.58	3.50	3.74

Type	S	T	U	V												
HD 790	3.66	4.80	4.02	0.51												
HD 990	3.66	4.80	4.02	0.51												

* 3/4-10 UNC-2B / 1.26

** 1/2-13 UNC-2B / 0.79

Symbols

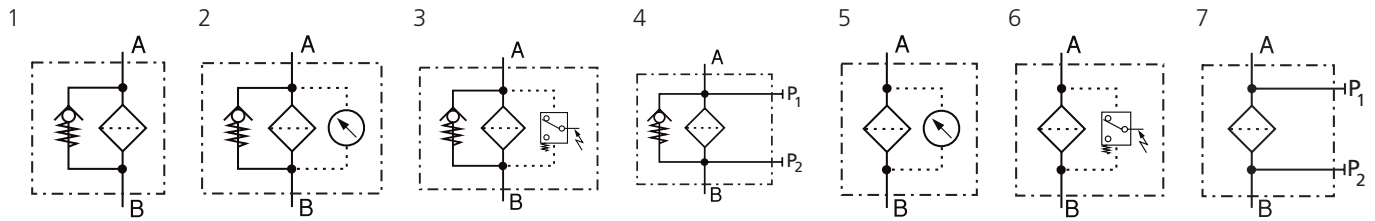

Spare Parts

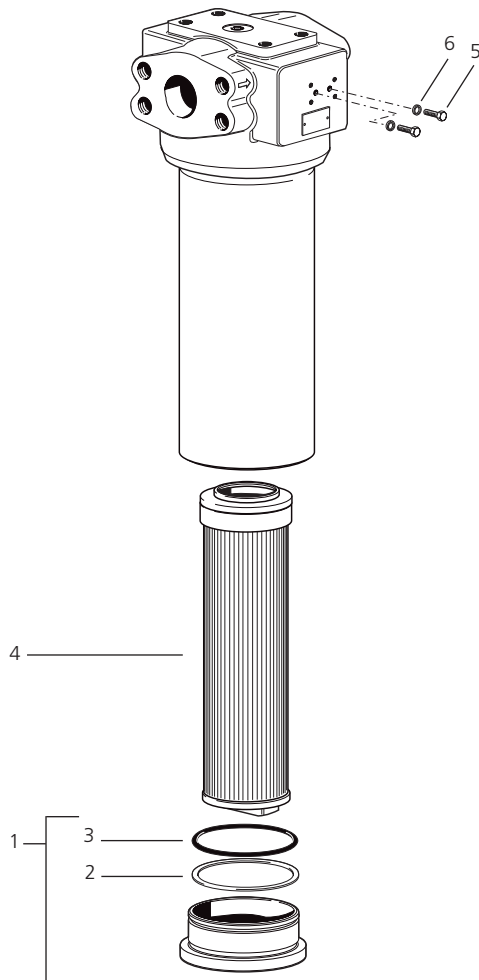

Pos.	Designation	Part No.
1	Housing cover (with Pos. 2 and 3)	HD 990.1900
2	Back-ring	HD 256.0104
3	O-ring 104.37 x 3.53 mm 4.11 x 0.14 inch	N007.1044S
4	Replacement filter element	see Chart / col. 9
5	Hexagonal head screw M4 x 8 ISO 4017-8.8	11385800
6	Bonded seal 4.1 x 7.2 x 1 mm 0.16 x 0.28 x 0.04 inch	12504600

The functions of the complete filters, as well as the outstanding features of the filter elements assured by ARGO-HYTOS, can only be guaranteed if original ARGO-HYTOS spare parts are used.

Quality Assurance

Quality management according to DIN EN ISO 9001

To ensure constant quality in production and operation, ARGO-HYTOS filter elements undergo strict controls and tests according to the following ISO standards:

ISO 2941	Verification of collapse / burst pressure rating
ISO 2942	Verification of fabrication integrity (Bubble Point Test)
ISO 2943	Verification of material compatibility with fluids
ISO 3968	Evaluation of pressure drop versus flow characteristics
ISO 16889	Multi-Pass-Test (evaluation of filter fineness and dirt-holding capacity)
ISO 23181	Determination of resistance to flow fatigue using high viscosity fluid

Before release into the series production the filter casing is tested for fatigue strength in our pressure pulse test rig. Various quality controls during the production process guarantee the leakfree function and solidity of our filters..

Illustrations may sometimes differ from the original. ARGO-HYTOS is not responsible for any unintentional mistake in this specification sheet.