

High Pressure Filters

HD 044 · HD 064

Flangeable · Operating pressure up to 500 bar / 7250 psi · Nominal flow rate up to 105 l/min / 27.7 gpm



High Pressure Filter HD 064

Description

Application

In the high pressure circuits of hydraulic systems.

Performance features

Protection against wear:

By means of filter elements that even in full-flow filtration meet the highest demands regarding cleanliness classes.

Protection against malfunction:

Through installation near to the control valves or other expensive components. The specific determined flow rate guarantees a closed by-pass valve even at $v \leq 200 \text{ mm}^2/\text{s}$ / 927 SUS (cold start condition).

Filter elements

Flow direction from outside to center.

The star-shaped pleating of the filter material results in:

- › large filter surfaces
- › low pressure drop
- › high dirt-holding capacities
- › long service life

Filter maintenance

By using a clogging indicator the correct moment for maintenance is stated and guarantees the optimum utilization of the filter life.

Materials

Filter head:	Spheroidal graphite cast iron (SGI)
Filter bowl:	Cold extruded steel
Coating:	Powder paint
Seals:	NBR (FPM on request)
Filter media:	EXAPOR®MAX 3 - inorganic multi-layer microfiber web

Accessories

Electrical and / or optical clogging indicators are available - optionally with one or two switching points resp. temperature suppression.

Dimensions and technical data see catalog sheet 60.30.

Operating pressure

0 ... 315 bar / 4570 psi, min. 2×10^6 pressure cycles
Nominal pressure according to DIN 24550

0 ... 500 bar / 7250 psi, min. 10^4 pressure cycles
Quasi-static operating pressure

Permissible pressures for other numbers of cycles

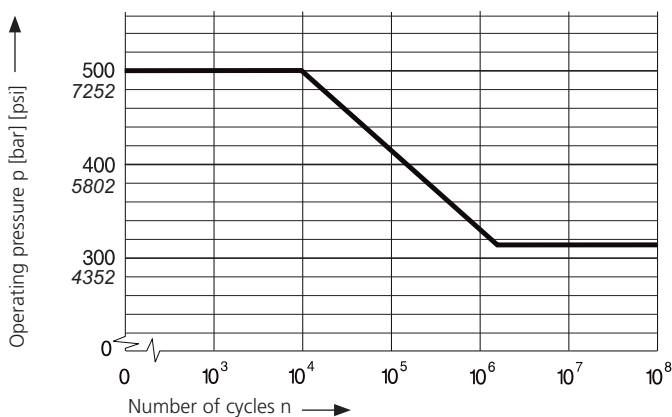

Nominal flow rate

Up to 105 l/min / 27.7 gpm (see Selection Chart, column 2)
The nominal flow rates indicated by ARGO-HYTOS are based on the following features:

- › closed by-pass valve at $v \leq 200 \text{ mm}^2/\text{s} / 927 \text{ SUS}$
- › element service life > 1000 operating hours at an average fluid contamination of 0.07 g per l/min / 0.27 g per gpm flow volume
- › flow velocity in the connection lines:
up to 250 bar $\leq 8 \text{ m/s} / 3626 \text{ psi} \leq 26.3 \text{ ft/s}$
> 250 bar $\leq 12 \text{ m/s} / 3626 \text{ psi} \leq 39.4 \text{ ft/s}$

Filter fineness

5 $\mu\text{m(c)}$... 16 $\mu\text{m(c)}$
 β -values according to ISO 16889
(see Selection Chart, column 4 and diagram Dx).

Dirt-holding capacity

Values in g test dust ISO MTD according to ISO16889
(see Selection Chart, column 5).

Hydraulic fluids

Mineral oil and biodegradable fluids
(HEES and HETG, see info-sheet 00.20).

Temperature range

-30 °C ... +100 °C (temporary -40 °C ... +120 °C)
-22 °F ... +212 °F (temporary -40 °F ... +248 °F)

Viscosity at nominal flow rate

- › at operating temperature: < 60 $\text{mm}^2/\text{s} / 280 \text{ SUS}$
- › as starting viscosity: $v_{\text{max}} = 1200 \text{ mm}^2/\text{s} / 5560 \text{ SUS}$
- › at initial operation:
The recommended starting viscosity can be read from the diagram D (pressure drop as a function of the kinematic viscosity) as follows: Find the 70% Δp of the cracking pressure of the by-pass valve on the vertical axis. Draw a horizontal line so that it intersects the Δp curve at a point. Read this point on the horizontal axis for the viscosity.

Mounting position

Preferably vertical, filter head on top.

Connection

2 x $\varnothing 15 \text{ mm} / 2 \times \varnothing 0.59 \text{ inch}$ on plain flange

For installation recommendations, see info sheet 00.325.

Δp-curves for complete filters in Selection Chart, column 3

D1 Pressure drop as a function of the **flow volume** at $v = 35 \text{ mm}^2/\text{s} / 162 \text{ SUS}$ (0 = casing empty)

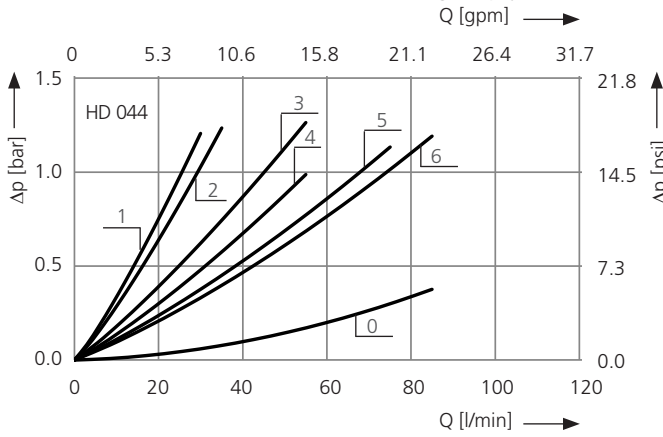

Pressure drop as a function of the **kinematic viscosity** at nominal flow

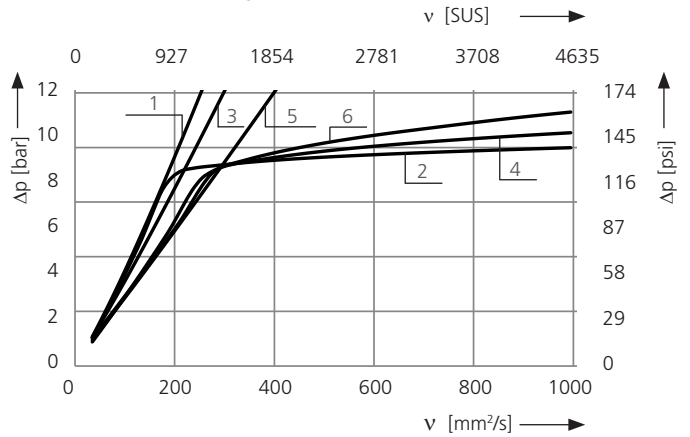

D2 Pressure drop as a function of the **flow volume** at $v = 35 \text{ mm}^2/\text{s} / 162 \text{ SUS}$ (0 = casing empty)

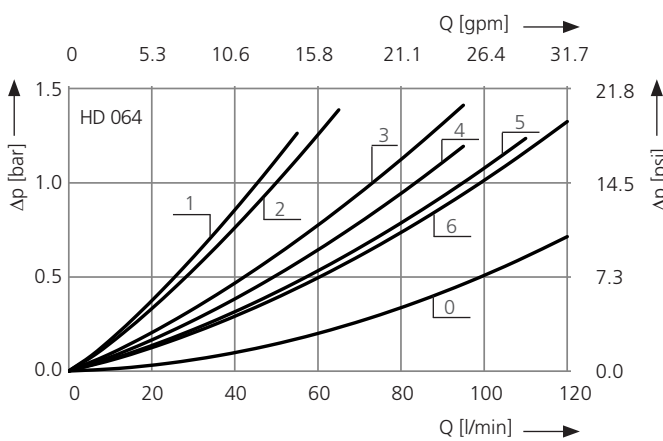

Pressure drop as a function of the **kinematic viscosity** at nominal flow

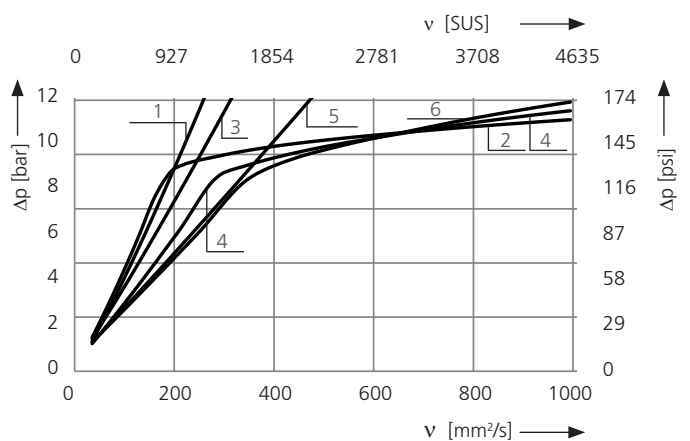

Filter fineness curves in Selection Chart, column 4

Dx Filtration ratio β as a function of particle size x obtained by the Multi-Pass-Test according to ISO 16889

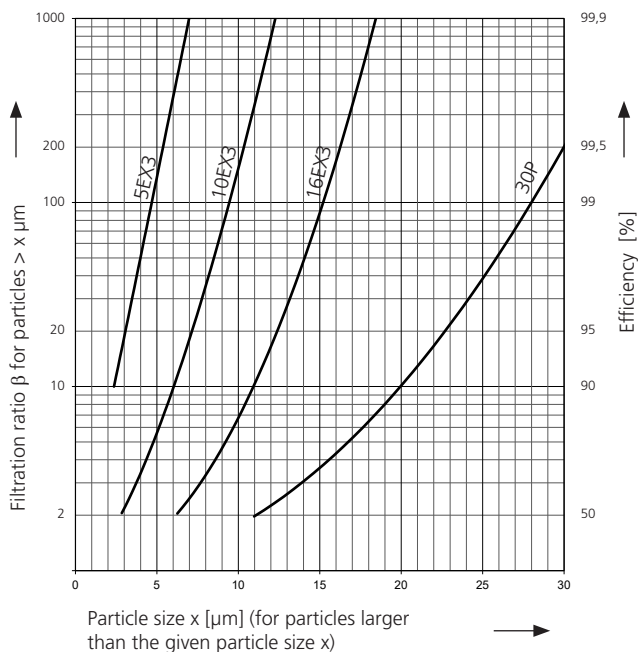

The abbreviations represent the following β -values resp. finenesses:

For EXAPOR[®]MAX 3 and Paper elements:

- 5EX3 = $\beta_{5(c)} = 200$ EXAPOR[®]MAX 3
- 10EX3 = $\beta_{10(c)} = 200$ EXAPOR[®]MAX 3
- 16EX3 = $\beta_{16(c)} = 200$ EXAPOR[®]MAX 3
- 30P = $\beta_{30(c)} = 200$ Paper

Based on the structure of the filter media of the 30P paper elements, deviations from the printed curves are quite probable.

For screen elements:

- 40S = screen material with mesh size 40 μm
 - 60S = screen material with mesh size 60 μm
 - 100S = screen material with mesh size 100 μm
- Tolerances for mesh size according to DIN 4189

For special applications, finenesses differing from these curves are also available by using special composed filter media.

Selection Chart

Part No.	Nominal flow rate		Pressure drop see diagram D1 /curve no.	Filter fineness see diagram Dx	Dirt-holding capacity			Connection A/B		Cracking pressure of by-pass	Symbol	Replacement filter element Part No.	Weight		Clogging indicator
	l/min	gpm			g	mm	inch	bar	psi				kg	lbs	
1	2		3	4	5	6			7	8	9	10		11	
HD 044-183	27	7.1	D1/1	5EX3	4.8	Ø 15	Ø 0.59	-	-	2	V3.0510-13 ²	3.4	7.5	retrofitable	
HD 044-153	30	7.9	D1/2	5EX3	5.6	Ø 15	Ø 0.59	7	102	1	V3.0510-03	3.4	7.5	retrofitable	
HD 044-186	47	12.4	D1/3	10EX3	5.1	Ø 15	Ø 0.59	-	-	2	V3.0510-16 ²	3.4	7.5	retrofitable	
HD 044-156¹	50	13.2	D1/4	10EX3	6.8	Ø 15	Ø 0.59	7	102	1	V3.0510-06	3.4	7.5	retrofitable	
HD 044-178	65	17.2	D1/5	16EX3	5.8	Ø 15	Ø 0.59	-	-	2	V3.0510-18 ²	3.4	7.5	retrofitable	
HD 044-158¹	75	19.8	D1/6	16EX3	6.9	Ø 15	Ø 0.59	7	102	1	V3.0510-08	3.4	7.5	retrofitable	
HD 064-183	50	13.2	D2/1	5EX3	8.7	Ø 15	Ø 0.59	-	-	2	V3.0520-13 ²	4.6	10.1	retrofitable	
HD 064-153	60	15.9	D2/2	5EX3	12	Ø 15	Ø 0.59	7	102	1	V3.0520-03	4.5	9.9	retrofitable	
HD 064-196	85	22.2	D2/3	10EX3	11	Ø 15	Ø 0.59	-	-	2	V3.0520-16 ²	4.6	10.1	retrofitable	
HD 064-156¹	85	22.2	D2/4	10EX3	14	Ø 15	Ø 0.59	7	102	1	V3.0520-06	4.5	9.9	retrofitable	
HD 064-178	100	26.4	D2/5	16EX3	12	Ø 15	Ø 0.59	-	-	2	V3.0520-18 ²	4.6	10.1	retrofitable	
HD 064-158¹	105	27.7	D2/6	16EX3	15	Ø 15	Ø 0.59	7	102	1	V3.0520-08	4.5	9.9	retrofitable	

¹ Preferred type, no minimum order quantity required

² Element differential pressure stable up to 160 bar / 2320 psi, clogging indicator is obligatory

Optical or electrical clogging indicators can be provided for clogging monitoring. When ordering filters with clogging indicator for self-assembly, the abbreviation "M" must be used in the order designation of the clogging indicator. The corresponding installation accessories and installation instructions are included.

Order example: The filter HD 064-156 has to be supplied with optical clogging indicator - response pressure 5.0 bar / 73 psi.

Order code: **HD 064-156** / **DG 042-02 M**

1. Part No. (Basic unit) _____

2. Part No. Clogging indicator _____

Suitable clogging indicators can be found in catalog sheet 60.30. These must be ordered separately and fitted by the customer. Installation instructions are enclosed.

Remarks:

- › Filter versions without by-pass valves must always be equipped with a clogging indicator.
- › The filters listed in this chart are standard filters. If modifications are required, e.g. filter fineness 30P, we kindly ask for your request.

Dimensions

Version with electrical clogging indicator DG 041

Version with optical clogging indicator DG 042

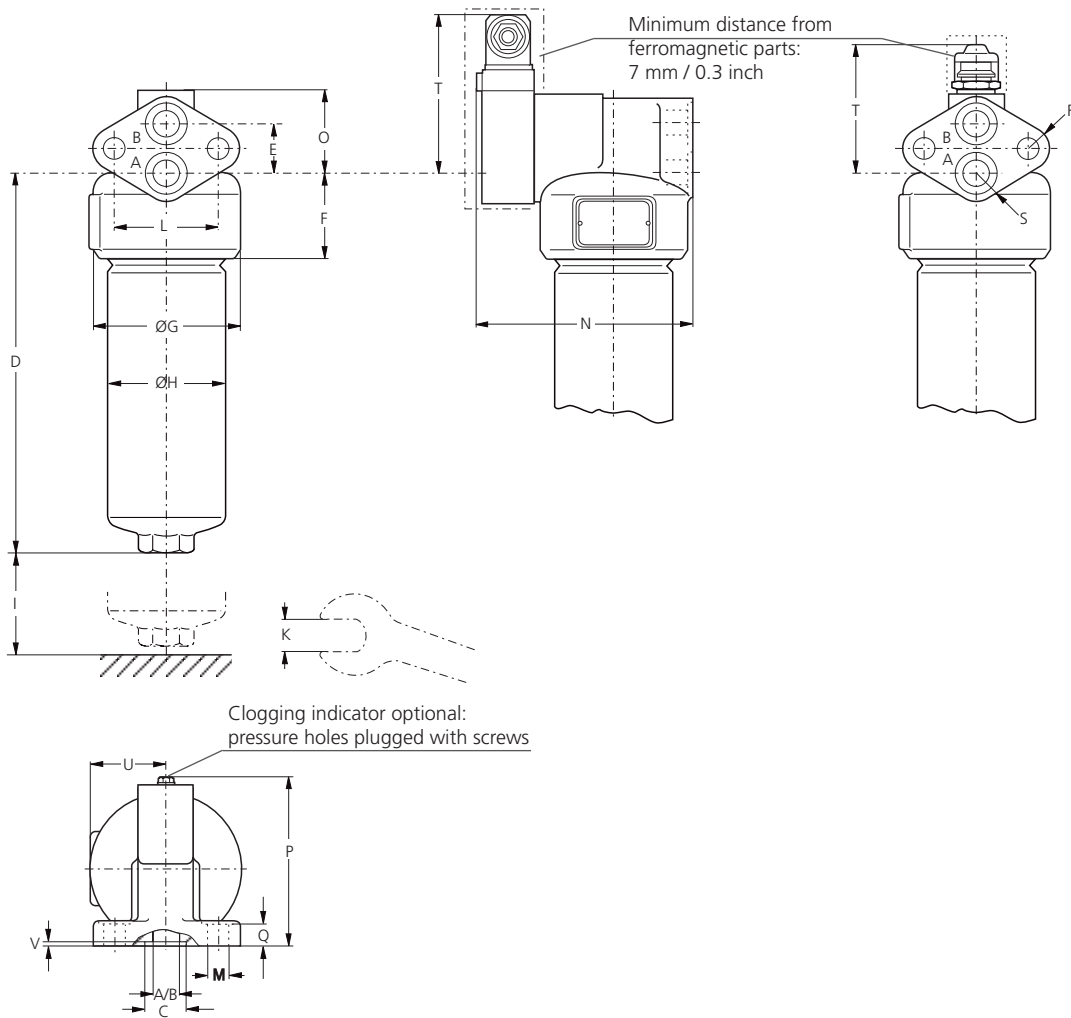

Measurements in mm

Type	A/B	C	D	E	F	G	H	I	K	L	M	N	O	P	Q	R	S	T	U	V
HD 044	Ø 15	23.5	145	26	49	83	66	70	AF 36	58	12.5	118.5	48	90	17	13	16	106 / 79	45	2
HD 064	Ø 15	23.5	241	26	49	83	66	70	AF36	58	12.5	118.5	48	90	17	13	16	106 / 79	45	2

Measurements in inch

Type	A/B	C	D	E	F	G	H	I	K	L	M	N	O	P	Q	R
HD 044	Ø 0.59	0.93	5.71	1.02	1.93	3.27	2.60	2.76	AF 36	2.28	0.49	4.67	1.89	3.54	0.67	0.51
HD 064	Ø 0.59	0.93	9.49	1.02	1.93	3.27	2.60	2.76	AF 36	2.28	0.49	4.67	1.89	3.54	0.67	0.51

Type	S	T	U	V
HD 044	0.63	4.17 / 3.11	1.77	0.08
HD 064	0.63	4.17 / 3.11	1.77	0.08

Symbols

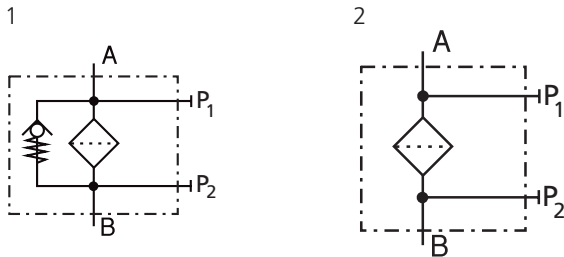

Spare Parts

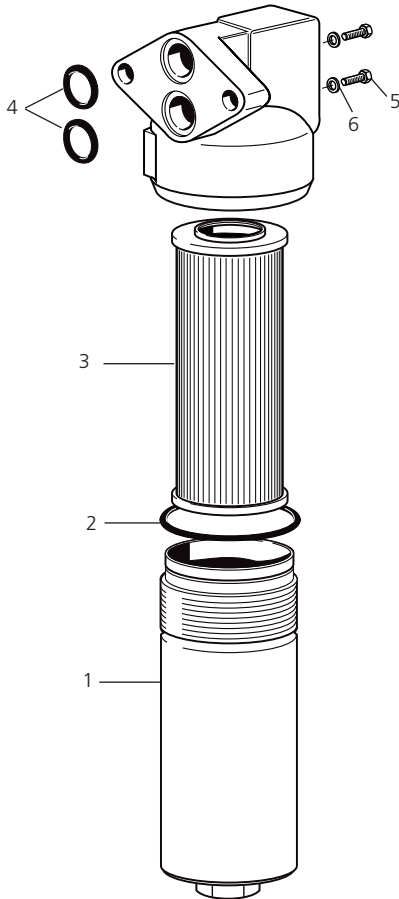

Pos.	Designation	Part No.
1	Filter bowl HD 044	HD 052.0102
1	Filter bowl HD 064	HD 072.0102
2	O-ring 53.57 x 3.53 mm 11 x 0.14 inch	N007.0543/1
3	Replacement filter element	s. Chart / col. 9
4	O-ring 18.72 x 2.62* mm 0.74 x 0.10* inch	N007.0193
5	Hexagonal head screw M4 x 8 DIN 933-8.8	11385800
6	Bonded Seal 4.1 x 7.2 x 1 mm 0.16 x 0.28 x 0.04 inch	12504600

*Not supplied with filter - has to be ordered separately

The functions of the complete filters as well as the outstanding features of the filter elements assured by ARGO-HYTOS can only be guaranteed if original ARGO-HYTOS spare parts are used.

Quality Assurance

Quality management according to DIN EN ISO 9001

To ensure constant quality in production and operation, ARGO-HYTOS filter elements undergo strict controls and tests according to the following ISO standards:

ISO 2941	Verification of collapse / burst pressure rating
ISO 2942	Verification of fabrication integrity (Bubble Point Test)
ISO 2943	Verification of material compatibility with fluids
ISO 3968	Evaluation of pressure drop versus flow characteristics
ISO 16889	Multi-Pass-Test (evaluation of filter fineness and dirt-holding capacity)
ISO 23181	Determination of resistance to flow fatigue using high viscosity fluid

Before release into the series production the filter casing is tested for fatigue strength in our pressure pulse test rig. Various quality controls during the production process guarantee the leakfree function and solidity of our filters.

Illustrations may sometimes differ from the original. ARGO-HYTOS is not responsible for any unintentional mistake in this specification sheet.