

Off-line Filter

FNS 060

With flow control valve · Operating pressure up to 320 bar / 4640 psi · Nominal flow rate up to 4 l/min / 1.1 gpm



Off-line Filter FNS 060

Description

Application

Suitable for high-pressure circuits in hydraulic and lubrication systems.

Performance features

Protection against wear:

The EXAPOR[®]MAX 2 ultra-fine element meets the highest cleanliness standards, even at full flow.

Protection against failure:

The off-line filter includes a feature that guarantees a closed by-pass valve even at $v \leq 200 \text{ mm}^2/\text{s}$ / 930 SUS (cold start condition) within specified operating parameters.

Special design features

Housing cover:

The cover can be opened without special auxiliary tools.

Flow control valve:

Through a pressure compensated flow control valve, the FNS off-line filters are directly connected to the high pressure pipe. The surplus volume (e.g. in circuits with fixed displacement pumps) from the high-pressure circuit is cleaned by the ultra-fine filter element.

Dirt retention valve:

At the bottom of the filter element, flow through from the inside to the outside, there is a dirt retention valve. This closes while pulling the filter element, which is hung up at the cover, out of the housing. Sedimented dirt is removed together with the filter element. Because of the cover design, the filter element change can be carried out almost without losing any oil.

Filter elements

Flow direction from the inside to the outside. The star-shaped pleating of the filter material results in:

- › large filter surfaces
- › low pressure drop
- › high dirt-holding capacities
- › particularly long maintenance intervals

Filter maintenance

By using a clogging indicator, the correct moment for maintenance is stated, what guarantees optimum utilization of the filter life.

Materials

Filter head:	Aluminum alloy
Filter housing:	Steel
Cover:	Aluminum alloy
Seals:	NBR (FPM on request)
Filter media:	EXAPOR®MAX 2 - inorganic, multi-layer microfiber web

Accessories

Water-absorbing filter elements EXAPOR®AQUA are available on request.
Electrical and / or optical clogging indicators are available on request.
For dimensions and technical data see catalog sheet 60.20.

Characteristics

Nominal flow rate

Up to 4 l/min / 1.1 gpm (see Selection Chart, column 2)
Refers to the medium flow rate of the flow control valve. With selection of the flow control valve, a sufficient surplus volume from the high-pressure circuit has to be guaranteed. If necessary, the machine manufacturer should be consulted.

Connection

Threaded port according to ISO 228 or DIN 13.
Sizes see Selection Chart, column 6
(other port threads on request)

Filter fineness

3 µm(c)
β-values according to ISO 16889
(see Selection Chart, column 4 and diagram Dx)

Dirt-holding capacity

The dirt-holding capacity values in grams from the ISO MTD test dust are in accordance with the ISO 16889 requirements (see Selection Chart, column 5).

Hydraulic fluids

Mineral oil and biodegradable fluids
(HEES and HETG, see info-sheet 00.20)

Temperature range

-30 °C ... +100 °C (temporary -40 °C ... +120 °C)
-22 °F ... +212 °F (temporary -40 °F ... +248 °F)

Viscosity at nominal flow rate

- › at operating temperature: $v < 35 \text{ mm}^2/\text{s} / 162 \text{ SUS}$
- › as starting viscosity: $v_{\text{max}} = 400 \text{ mm}^2/\text{s} / 5560 \text{ SUS}$

Operating pressure

Max. 320 bar / 4640 psi
(max. 5 bar / 73 psi without pressure compensated flow control valve)
Minimum inlet pressure at the pressure compensated flow control valve: 10 bar / 145 psi

Mounting position

Vertical, connection port at the bottom

Δp-curves for complete filters in Selection Chart, column 3

D1 Flow volume as a function of the differential pressure at the flow control valve at $v = 35 \text{ mm}^2/\text{s} / 162 \text{ SUS}$

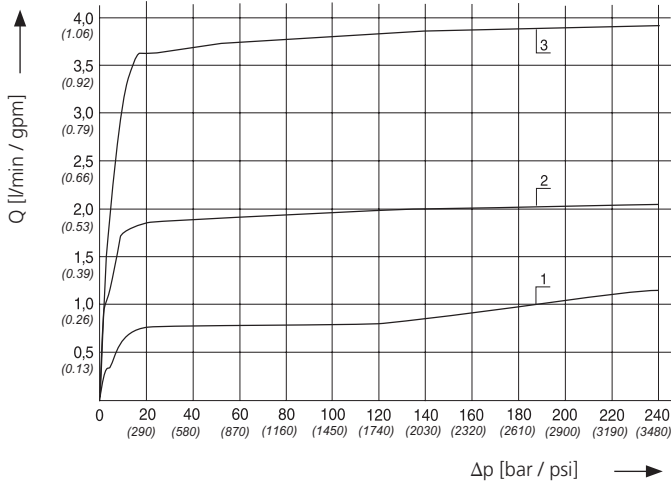

Filter fineness curves in Selection Chart, column 4

Dx Filtration ratio β as a function of particle size x obtained by the Multi-Pass Test according to ISO 16889

The abbreviations represent the following β -values resp. finenesses:

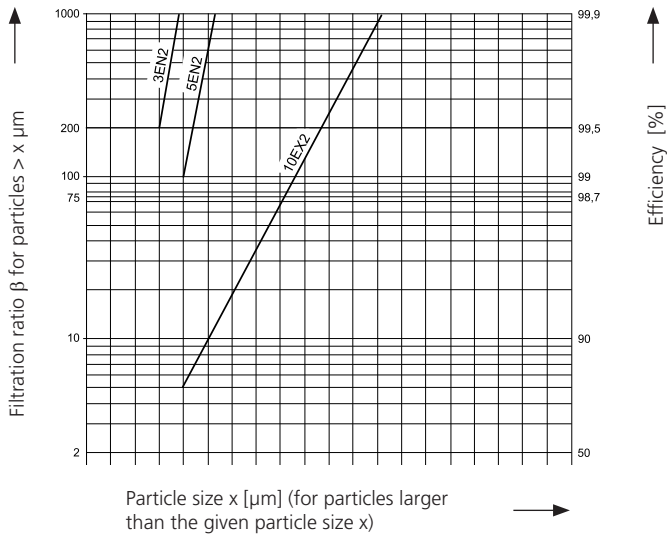

With EXAPOR®MAX2 and paper elements:

3EN2	=	$\bar{\beta}_3(c)$	= 200	EXAPOR®MAX 2
5EN2	=	$\bar{\beta}_5(c)$	= 200	EXAPOR®MAX 2
10EX2	=	$\bar{\beta}_{10}(c)$	= 200	EXAPOR®MAX 2

For special applications, finenesses differing from these curves are also available by using special composed filter media.

Selection Chart

Part No.	Nominal flow rate		Pressure drop see diagram D1 /curve no.	Filter fineness s. diagram Dx	Dirt-holding capacity	Connection A/B		Cracking pressure of by-pass	Symbol	Replacement filter element Part No.	Weight		Clogging indicator	Flow control valve	Remarks	
	l/min	gpm				g	bar				psi	kg				lbs
1	2		3	4	5	6		7	8	9	10		11	12	13	
FNS 060-163	*	*	D1 /*	3EN2	1450	G1/G1		3.5	51	1	V7.1230-153	5.2	11.5	option	option	basic unit
FNS 060-183	4	1.06	D1 /3	3E-A	130	G1/G1		3.5	51	2	Y7.1230-153	5.3	11.7	option	FNS 060.1540	
Pressure compensated flow control valve - inlet pressure min. 10 bar / 145 psi, max. 320 bar / 4640 psi:																
FNS 060.1520	1	0.26	D1 /1			G1/G $\frac{3}{4}$										–
FNS 060.1530	2	0.53	D1 /2			G1/G $\frac{3}{4}$										–
FNS 060.1540	4	1.06	D1 /3			G1/G $\frac{3}{4}$										–

* see nominal flow rate of the flow control valves

The housing of the off-line filter is designed for a max. operating pressure of 5 bar / 73 psi. To avoid back pressures, no components such as ball valves must be inserted at the housing outlet and in the continuative circuit.

For contamination monitoring, manometers or electrical pressure switches can be used.

For appropriate clogging indicators, please refer to catalog sheet 60.20.

Remarks:

- › The cut-in pressure of the pressure switch must be lower than the cracking pressure of the by-pass valve (see Selection Chart, column 7).
- › Clogging indicators and flow control valves are optionally available and will be supplied separately if ordered.
- › The off-line filters listed in this chart are standard units. If modifications are required, e.g. with water-absorbing filter elements, we kindly ask for your request.

Dimensions

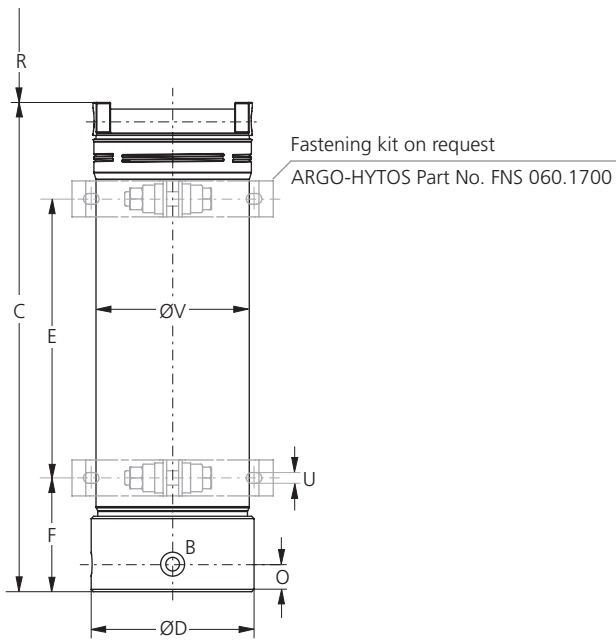
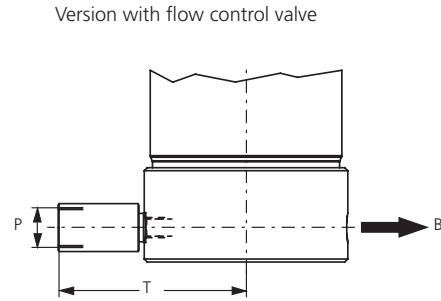
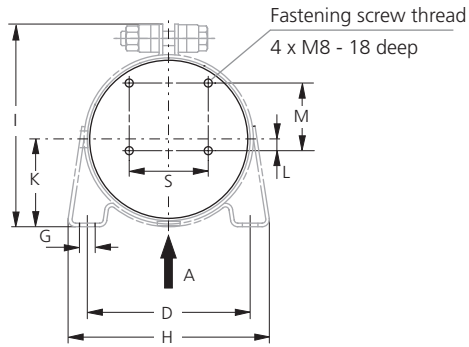

Version with manometer

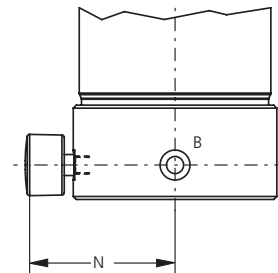

Measurements in mm

Type	A/B	C	D	E	F	G	H	I	K	L	M	N	O	P	R	S	T	U	V
FNS 060	G1	410	136	233	95	12	170	169	73	9.5	56.5	103	23	G $\frac{3}{4}$	300	66	119	9	128

Measurements in inch

Type	A/B	C	D	E	F	G	H	I	K	L	M	N	O	P	R
FNS 060	G1	16.14	5.35	9.17	3.74	0.47	6.69	6.65	2.87	0.37	2.22	4.06	0.91	G $\frac{3}{4}$	11.81

Type	S	T	U	V
FNS 060	2.60	4.69	0.35	5.04

Symbols

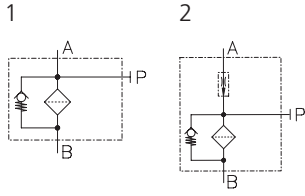

Spare Parts

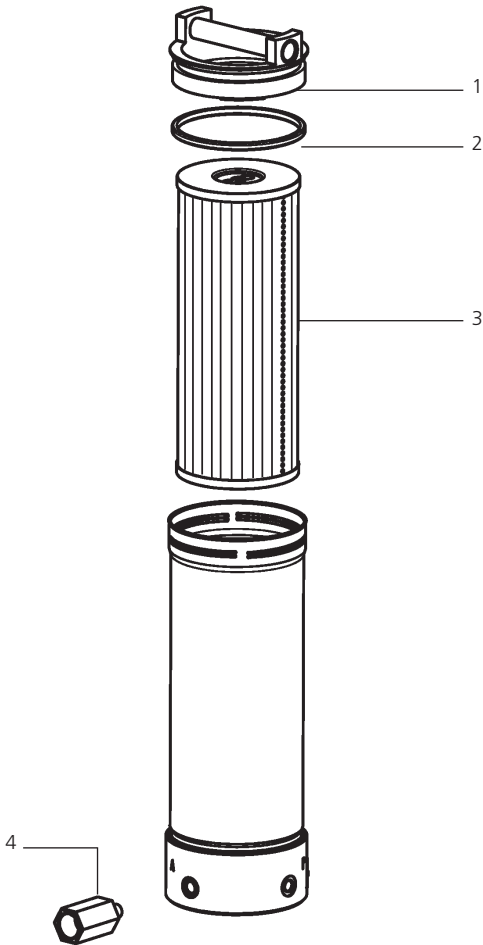

Pos.	Designation	Part No.
1	Cover	FNA 008.1250
2	O-ring	N007.1175
3	Filter element	s. Selection Chart
4	Flow control valve	s. Selection Chart

The functions of the complete filters as well as the outstanding features of the filter elements assured by ARGO-HYTOS can only be guaranteed if original ARGO-HYTOS spare parts are used.

Quality Assurance

Quality management according to DIN EN ISO 9001

To ensure constant quality in production and operation, ARGO-HYTOS filter elements undergo strict controls and tests according to the following ISO standards:

ISO 2941	Verification of collapse / burst pressure rating
ISO 2942	Verification of fabrication integrity (Bubble Point Test)
ISO 2943	Verification of material compatibility with fluids
ISO 3968	Evaluation of pressure drop versus flow characteristics
ISO 16889	Multi-Pass-Test (evaluation of filter fineness and dirt-holding capacity)
ISO 23181	Determination of resistance to flow fatigue using high viscosity fluid

Various quality controls during the production process guarantee the leak-free function and solidity of our filters.

Illustrations may sometimes differ from the original. ARGO-HYTOS is not responsible for any unintentional mistake in this specification sheet.