

Off-line Filters

FN1 040

In-line mounting · Operating pressure up to 12 bar / 174 psi · Nominal flow rate 40 l/min / 10.6 gpm

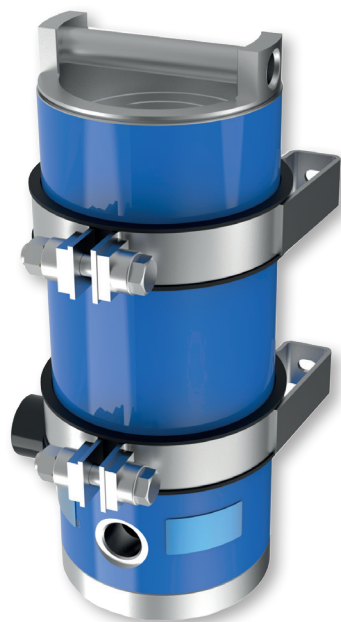

Off-line Filter FN1 040

Description

Application

Return-flow filter or off-line filter in hydraulic and lubrication systems.

Performance features

The EXAPOR®MAX 2 and EXAPOR®AQUA ultra-fine elements are the heart of the ARGO-HYTOS off-line filters. High separation efficiencies guarantee excellent cleanliness levels and thereby highest protection of components. The high dirt and water capacity of the EXAPOR®MAX 2 and EXAPOR®AQUA elements allows economical operation of the machine.

Special design features

User-friendly filter element change:

The cover of the FN 040 can be opened without special auxiliary tools. The filter element can be removed from the housing together with the cover.

Dirt retention valve:

The element is flown through from the inside to the outside. The built-in dirt retention valve closes automatically when the element is removed, ensuring that all dirt is removed from the housing together with the element. Because of the cover design, the filter element change can be carried out almost without losing any oil.

Filter elements

Flow direction from the inside to the outside. The star-shaped pleating of the filter material results in:

- › large filter surfaces
- › low pressure drop
- › high dirt-holding capacities
- › particularly long maintenance intervals

Operating pressure

Max. 12 bar / 174 psi

Cracking pressure of by-pass

3.5 bar / 51 psi

Nominal flow rate

40 l/min / 10 gpm up to 60 l/min / 15 gpm

The nominal flow rates indicated by ARGO-HYTOS are based on the following features:

- › closed by-pass valve at $v \leq 200 \text{ mm}^2/\text{s}$ / 930 SUS
- › element service life > 1000 operating hours at an average fluid contamination of 0.07 g per l/min / 0.27 g per gpm flow volume
- › flow velocity in the connection lines:
up to 10 bar $\leq 4.5 \text{ m/s}$ / 145 psi $\leq 14.8 \text{ ft/s}$

Filter fineness

- › 3 $\mu\text{m(c)}$... 10 $\mu\text{m(c)}$ for EXAPOR®MAX 2 separating solid particles
- › 3 $\mu\text{m(c)}$... 7 $\mu\text{m(c)}$ for EXAPOR®AQUA separating water and solid particles

β -values according to ISO 16889

(see Ordering Code, table filter element)

Dirt-holding capacity

The dirt-holding capacity values in grams from the ISO MTD test dust are in accordance with the ISO 16889 requirements (see Ordering Code, table Filter Element).

Materials

Filter housing: Aluminum alloy powder painted RAL 5015

Filter end plate: Aluminum alloy

Cover: Aluminum alloy

Seals: NBR (FPM on request)

Filter media: EXAPOR®MAX 2 - inorganic, multi-layer microfiber web
EXAPOR®AQUA - combination of water absorbing filter layers and inorganic, multi-layer microfiber web

Remarks

Other colors of the filter housing are available on request. Special versions, not shown in this catalog, are also available on request.

Hydraulic fluids

Mineral oil and biodegradable fluids (HEES and HETG, see info-sheet 00.20)

Temperature range

-30 °C ... +100 °C (temporary -40 °C ... +120 °C)

-22 °F ... +212 °F (temporary -40 °F ... +248 °F)

Viscosity at nominal flow rate

- › at operating temperature: $v < 35 \text{ mm}^2/\text{s}$ / 162 SUS
- › as starting viscosity: $v_{\text{max}} = 1200 \text{ mm}^2/\text{s}$ / 5560 SUS
- › at initial operation:
The recommended starting viscosity can be read from the diagram D (pressure drop as a function of the kinematic viscosity) as follows: Find the 70% Δp of the cracking pressure of the by-pass valve on the vertical axis. Draw a horizontal line so that it intersects the Δp curve at a point. Read this point on the horizontal axis for the viscosity.

Mounting position

Vertical, connection port at the bottom

Weight

Without mounting clamps: 6.7 kg / 14.77 lbs

With mounting clamps: 8.3 kg / 18.3 lbs

Connection

Threaded ISO 228 or UNF ports (see Dimensions Drawing)

Accessories

A mounting kit (2 pcs of mounting clamps) may be ordered together with the off-line filter (M in the order code) or separately (order code FNS 060.1730).

Electrical and / or optical clogging indicators may be ordered together with the off-line filter. For choosing the proper clogging indicator, see table Clogging Indicator in the Ordering Code. The clogging indicator can be ordered separately. For dimensions and technical data of the clogging indicators, see catalog sheets 60.20 and 60.30.

Ordering Code

FN1 040 - - - -

Type of filter	Code
Off-line filter	FN1

Nominal flow rate	Code
40 l/min / 10 gpm	040

Connection port	Code
In: G1 Out: G $\frac{3}{4}$	G
In: 1 $\frac{5}{16}$ -12 UN-2B Out: 1 $\frac{1}{16}$ -12 UN-2B	U

Filter element						Code
	Fineness ($\beta=200$) Dirt-holding capacity at nominal flow 40 l/min / 10 gpm		Water capacity	Cracking pressure of by-pass	Spare filter element code	
EXAPOR [®] MAX 2	3 μ m	190 g	-	3.5 bar / 51 psi	V7.1220-113	V003
EXAPOR [®] MAX 2	5 μ m	190 g	-	3.5 bar / 51 psi	V7.1220-13	V005
EXAPOR [®] MAX 2	10 μ m	148 g	-	3.5 bar / 51 psi	V7.1220-06	V010
EXAPOR [®] AQUA	3 μ m	80.5 g	300 ml	3.5 bar / 51 psi	Y7.1220-113	Y003
EXAPOR [®] AQUA	7 μ m	60.5 g	330 ml	3.5 bar / 51 psi	Y7.1220-05	Y007

Clogging indicator					Code
Type		Code of indicator	Connection	Hydraulic symbol	
Manometer	optical	DG 200-16	M12 x 1.5	1	O
Pressure switch	electrical	DG 813-21	M12 x 1.5	2	E
Pressure switch	optical / electrical	DG 815-12	M12 x 1.5	3	EO
	without indicator		M12 x 1.5	4	X
Differential pressure clogging indicator	optical	DG 042-01	Flange	5	OD
	electrical	DG 041-31	Flange	6	ED
	optical + electrical	DG 041-44	Flange	7	EOD
	without indicator		Flange	8	XD

Mounting clamps	Code
No	
Yes	M

Order example:

FN1 040G-Y003-ED off-line filter with inlet port G1, outlet port G $\frac{3}{4}$, water absorbing filter element 3 μ m, electrical differential pressure clogging indicator, without mounting clamps.

Remarks:

Combinations listed in this order code are standard units. If modifications are required, we kindly ask for your request. For preferred types (available in short time) see table at the last page of this data sheet.

D1 FN1 040 with **EXAPOR®MAX 2** filter element
Pressure drop as a function of the **flow volume**
at $v = 35 \text{ mm}^2/\text{s} / 162 \text{ SUS}$

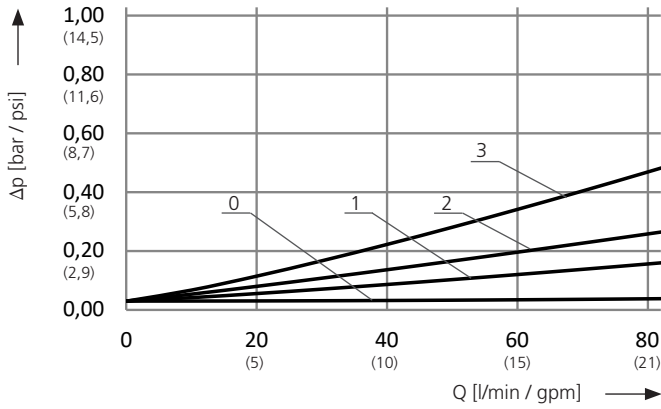

- 0 = housing empty
- 1 = with EXAPOR®MAX 2 filter element 10 μm
- 2 = with EXAPOR®MAX 2 filter element 5 μm
- 3 = with EXAPOR®MAX 2 filter element 3 μm

FN1 040 with **EXAPOR®MAX 2** filter element
Pressure drop as a function of the **kinematic viscosity**
at nominal flow

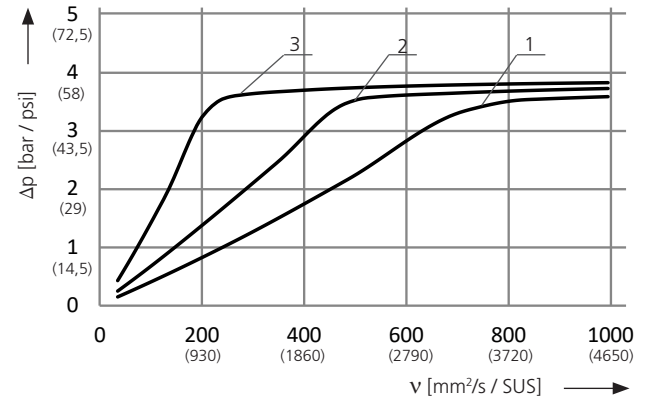

D2 FN1 040 with **EXAPOR®AQUA** filter element
Pressure drop as a function of the **flow volume**
at $v = 35 \text{ mm}^2/\text{s} / 162 \text{ SUS}$

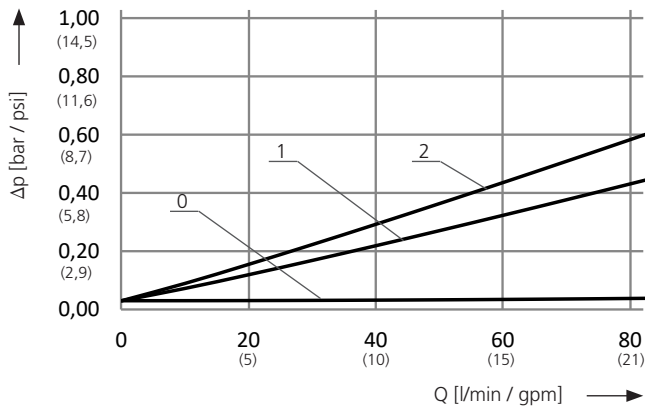

- 0 = housing empty
- 1 = with EXAPOR®AQUA filter element 7 μm
- 2 = with EXAPOR®AQUA filter element 3 μm

FN1 040 with **EXAPOR®AQUA** filter element
Pressure drop as a function of the **kinematic viscosity**
at nominal flow

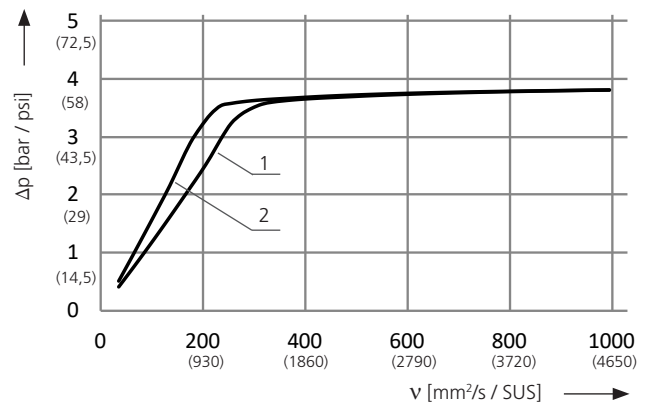

Dimensions

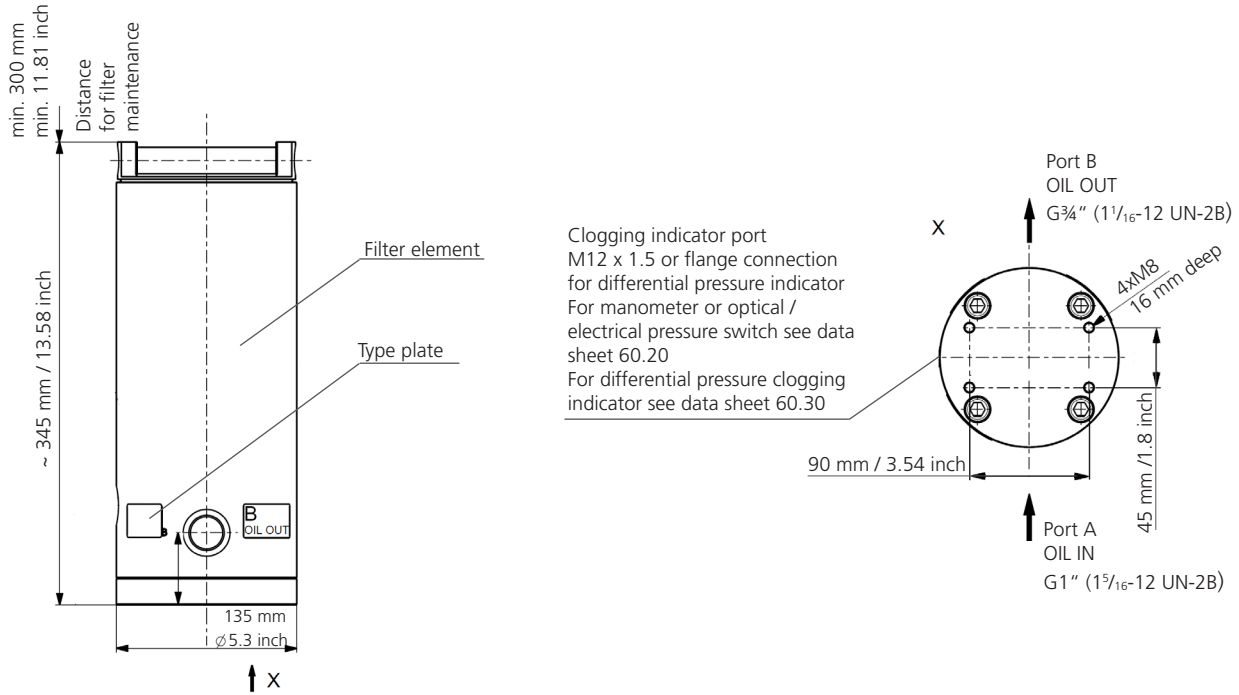

Version with mounting clamps (order code M)

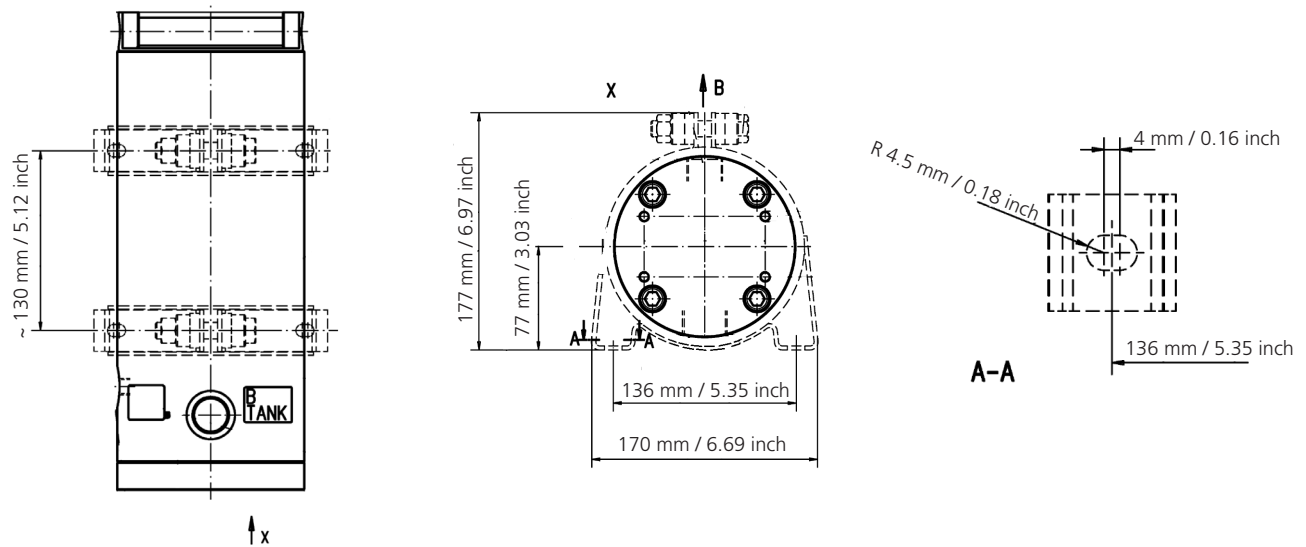

Preferred types

Order code	Port A	Port B	Filter fineness ($\beta=200$)	Dirt-holding capacity	Water capacity	Replacement filter element	Hydraulic symbol	SAP number
FN1 040G-V003-X	G1	G $\frac{3}{4}$	3 μ m	190 g	-	V7.1220-113	4	42496500
FN1 040G-V003-XD	G1	G $\frac{3}{4}$	3 μ m	190 g	-	V7.1220-113	8	42496700
FN1 040G-Y003-X	G1	G $\frac{3}{4}$	3 μ m	80.5 g	300 ml	Y7.1220-113	4	42496200
FN1 040G-Y003-XD	G1	G $\frac{3}{4}$	3 μ m	80.5 g	300 ml	Y7.1220-113	8	42496300
FN1 040U-V003-X	1 $\frac{5}{16}$ -12 UN-2B	1 $\frac{1}{16}$ -12 UN-2B	3 μ m	190 g	-	V7.1220-113	4	42496400
FN1 040U-V003-XD	1 $\frac{5}{16}$ -12 UN-2B	1 $\frac{1}{16}$ -12 UN-2B	3 μ m	190 g	-	V7.1220-113	8	42496600

Hydraulic symbols

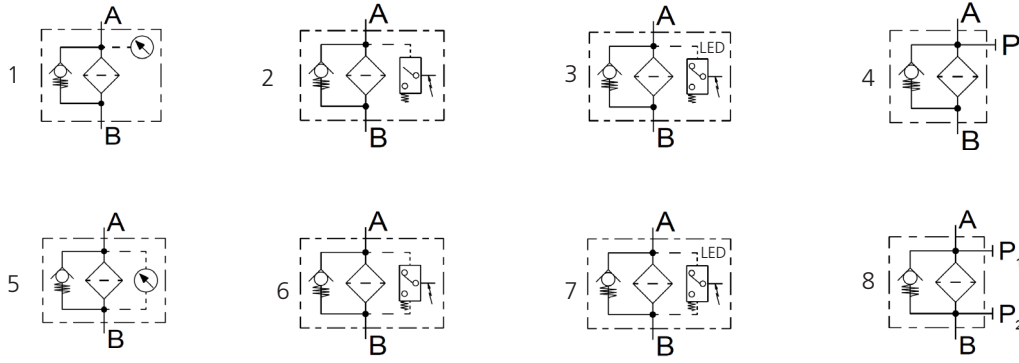

Quality Assurance

Quality management according to DIN EN ISO 9001

To ensure constant quality in production and operation, ARGO-HYTOS filter elements undergo strict controls and tests according to the following ISO standards:

ISO 2941	Verification of collapse / burst pressure rating
ISO 2942	Verification of fabrication integrity (Bubble Point Test)
ISO 2943	Verification of material compatibility with fluids
ISO 3968	Evaluation of pressure drop versus flow characteristics
ISO 16889	Multi-Pass-Test (evaluation of filter fineness and dirt-holding capacity)
ISO 23181	Determination of resistance to flow fatigue using high viscosity fluid

Various quality controls during the production process guarantee the leak-free function and solidity of our filters.

Illustrations may sometimes differ from the original. ARGO-HYTOS is not responsible for any unintentional mistake in this specification sheet.