

Oil Service Units

FA1 008

Easy filling and cleaning · Compact design · Comfortable handling · Great filtration efficiency



Oil Service Unit FA1 008

Description

FA1 008 – quick, simple and compact

With the Oil Service Unit FA 008, hydraulic and lubricating systems can be easily filled or cleaned.

Protection of components through ultra-fine filtration

The EXAPOR®MAX 2 ultra-fine elements are the heart of the ARGO-HYTOS filtering units FA1 008. High separation efficiencies guarantee excellent cleanliness levels and thereby highest protection of components. The high dirt holding capacity of the EXAPOR®MAX 2 ultra-fine elements allows economic operation of the FA1 008.

Characteristics

Nominal flow rate

Up to 8 l/min / 2.11 gpm

Viscosity range * (continuous operation)

15 mm²/s / 70 SUS up to 250 mm²/s / 1175 SUS

* for units with extended viscosity range see datasheet of the FA1HV 008/016 devices

Operating pressure

max. 4 bar / 58 psi

Hydraulic fluids

Mineral and biodegradable oils. Other fluids on request.

Temperature range of fluids

0 °C ... +65 °C / +32 °F ... +149 °F (also see viscosity range)

Ambient temperature range

0 °C ... +50 °C / +32 °F ... +122 °F

Maximum suction height

1.5 m / 4.9 ft

Operating position

Vertical, motor at the bottom

Weight

approx. 18 kg / 39.7 lbs

Recommended tank capacities

Up to 800 l / 200 gal



Compact design

The compact design allows easy access to the oil tank. The FA1 008 comes ready to connect, with hose packages.

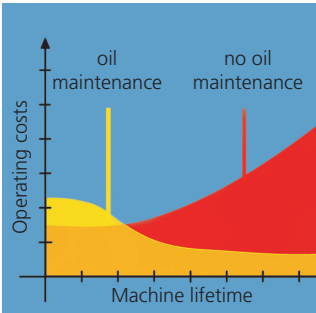

Economical

The FA1 008 Oil Service Unit offers protection that can extend the lifetime of machinery. This protection gives a direct return on investment through extended service intervals and increased machine availability.



User-friendly filter element change

The filter element can be removed from the housing together with the cover. The dirt retention valve ensures that solid particle sediment is completely removed with the filter element.

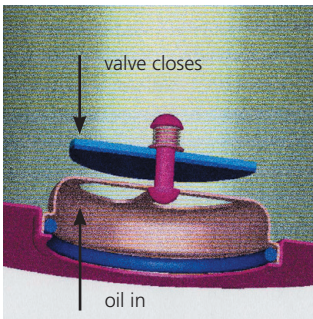

Maintenance-free filter housing due to a clever filter element technique

Fluid flows through the element from the inside to the outside. The built-in dirt retention valve closes automatically when the element is removed, ensuring that all dirt is removed from the housing with the element.

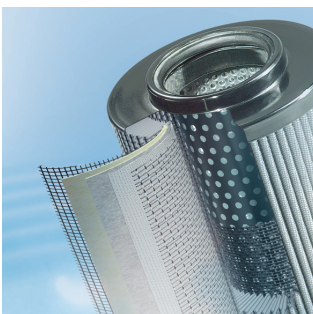

Quality in detail

The EXAPOR[®]MAX 2 fine element is the heart of the FA1 008. High cleanliness levels protect the hydraulic system against contamination during the oil filling process.

Ordering code

Type of unit		Code			
Oil service unit - standard version		FA1			
Nominal flow rate		Code			
8 l/min / 2.11 gpm*		008			
Filter element				Code	
	Fineness ($\beta=200$) Dirt-holding capacity according to ISO 16889	Water capacity	Spare filter element		
EXAPOR®MAX 2	3 μm	490 g	-	V7.1220-113	V003
EXAPOR®MAX 2	5 μm	460 g	-	V7.1220-13	V005
EXAPOR®MAX 2	10 μm	340 g	-	V7.1220-06	V010
EXAPOR®AQUA	7 μm	145 g	320 ml	Y7.1220-05	Y007
EXAPOR®AQUA	3 μm	165 g	340 ml	Y7.1220-113	Y003
Electric motor				Code	
Phase(s), voltage	Frequency	Power	Electric plug		
1~220-240 VAC	50/60 Hz	0.25 kW*	1	23050	
3~400/460 VAC	50/60 Hz	0.25 kW*	2	40050	
Clogging indicator				Code	
Type	Code of indicator	Datasheet number	Hydraulic symbol		
Optical - manometer	DG 200-16	60.20	1	O	
Optical - differential pressure indicator	DG 042-01	60.30	2	OD	
Pressure hose extension **					
Customized length of the pressure hose (max. 5 m / 16.4 ft) Example of order P4.5 - pressure hose length 4.5 m / 14.8 ft				Px.x	
Electric cable extension ***					
Customized length of the electric cable Example of order C8.5 - electric cable length 8.5 m / 27.8 ft equipped with electric plug				Cx.x	

* Indications at 50 Hz. At 60 Hz the value increases by approx. 20%

** As standard, the unit is equipped with the following hoses

Suction hose: DN 19, length 1.8 m / 5.9 ft with suction filter 300 μm , \varnothing approx. 49 mm / 1.9 inch (installed at the free end of the hose)

Pressure hose: DN 19, length 2.0 m / 6.6 ft with aluminum lance length 25 cm (installed at the free end of the hose)

*** As standard, the unit is equipped with an electric cable, length 2.5 m / 8.2 ft.

Accessories:

- › Suction strainer set FA 016.1775 for tank openings on request, in case the existing suction strainer cannot be used.
- › Mounting set FA 008.1700 for tank openings with ventilating filter, e.g. as service connection on request.

Order example:

FA1 008V005/23050-OP3.5 - oil service unit, nominal flow 8 l/min / 2.11 gpm, filter element 5 μm , motor 1~230 VAC, optical manometer, standard suction hose, customized pressure hose, length 3.5 m / 11.5 ft, standard electric cable.

Dimensions

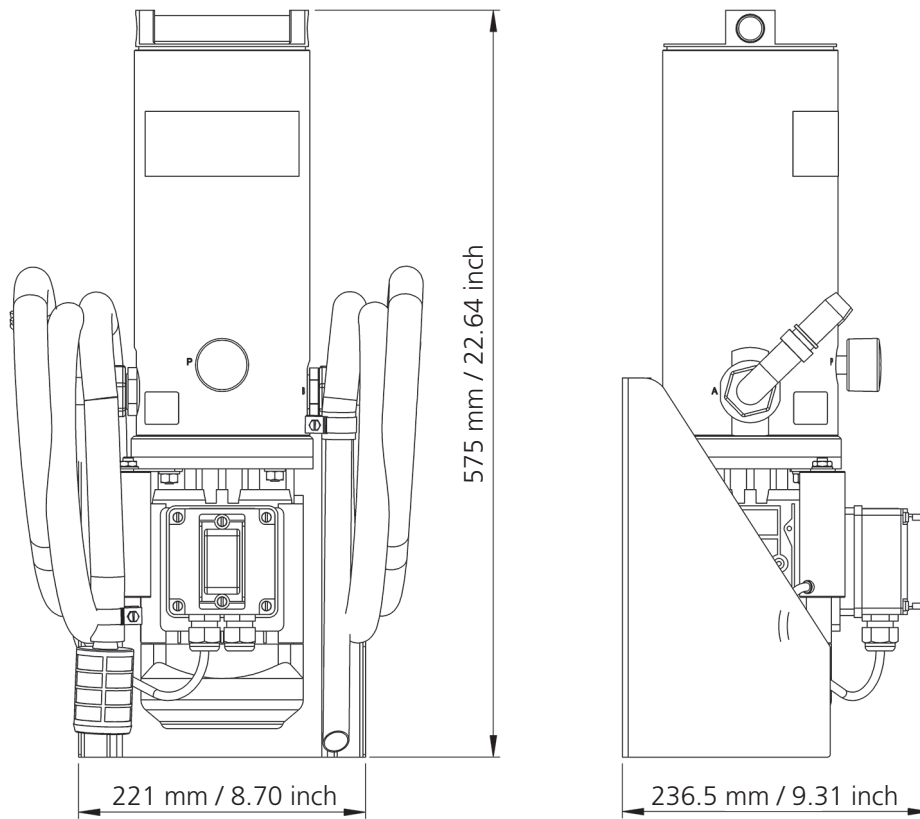

Hydraulic symbols

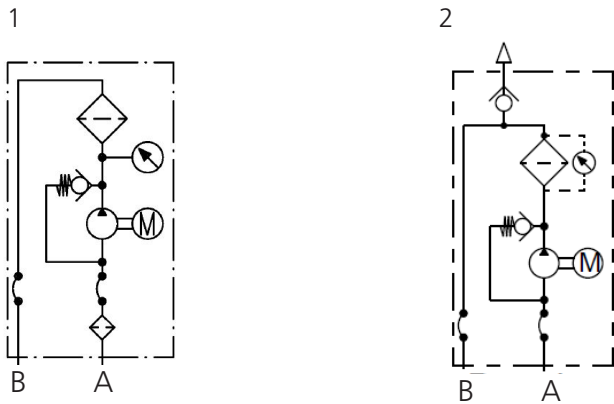

Electric plug*

1: Type E/F (CEE7/7 Unischuko)

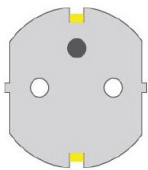

2: With phase crossover, 5-pins (3P+N+PE), IEC 60309

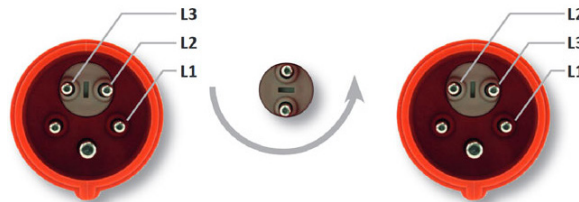

* other plugs on request