

Return Filters

E 444 · E 454 · E 464 · E 644

Tank top mounting · Connection up to SAE 2 · Nominal flow rate up to 680 l/min / 179.7 gpm



Return Filter E 454

Description

Application

In the return line circuits of hydraulic systems.

Performance features

Protection against wear:

By means of filter elements that even in full-flow filtration meet the highest demands regarding cleanliness classes.

Protection against malfunction:

By means of full-flow filtration in the system return, the pumps above all are protected from dirt particles remaining in the system after assembly, repairs, or which are generated by wear or enter the system from outside.

Special features

- › By-pass valve:
The location close to the inlet port prevents dirt particles retained by the filter element from entering into the clean oil side.
- › Removable bowl:
In case of maintenance the filter bowl is removed together with the filter element - therefore dirt particles are not flushed back into the tank.
- › AirEX air separation:
Prevents impairments and damage caused by air in the hydraulic medium and enables a significant reduction in tank size.

Filter elements

Flow direction from outside to center.

The star-shaped pleating of the filter material results in:

- › large filter surfaces
- › low pressure drop
- › high dirt-holding capacities
- › long service life

In filters with a magnetic system, the ferromagnetic particles in the fluid pass first through a strong magnetic field and are separated.

Filter maintenance

By using a clogging indicator the correct moment for maintenance is stated and guarantees the optimum utilization of the filter life.

Materials

Filter head cover:	Aluminum alloy
Filter head:	Aluminum alloy
Housing:	Steel, phosphated
Housing bottom:	Polyamide, GF reinforced
Seals:	NBR (FPM on request)
Filter media:	EXAPOR®MAX 3 - inorganic multi-layer microfiber web Paper - cellulose web, impregnated with resin, stainless steel wire mesh (1.4301)

Accessories

On request, the filters can be supplied with air separation, extension pipes or diffusers at the filter outlet. A combination of individual options is also possible on request.

- › Extension pipe:
A correct extension pipe length ensures oil outlet below minimum oil level and prevents foaming.
- › Diffuser:
Diffusers reduce oil velocity and direct the oil to 90° outlet flow. This function prevents also oil foaming and whirling up of solid particles settled at the tank bottom. The mesh screen element filters the oil in case of an open by-pass valve.

Electrical and optical clogging indicators are available on request. Dimensions and technical data see catalogue sheet 60.20.

Characteristics

Nominal flow rate

Up to 680 l/min / 179.7 gpm (see Selection Chart, column 2).
The nominal flow rates indicated by ARGO-HYTOS are based on the following features:

- › closed by-pass valve at $v \leq 200 \text{ mm}^2/\text{s}$ / 927 SUS
- › element service life > 1000 operating hours at an average fluid contamination of 0.07 g per l/min / 0.27 g per gpm flow volume
- › flow velocity in the connection lines $\leq 4.5 \text{ m/s}$ / 14.8 ft/s

Connection

Threaded ports according to

- › ISO 228 or DIN 13
- › SAE standard J514 and
- › SAE-flange (3000 psi)

Sizes see Selection Chart, column 6,
(other port threads on request).

For installation recommendations, see info sheet 00.325.

Filter fineness

5 $\mu\text{m(c)}$... 60 $\mu\text{m(c)}$

β -values according to ISO 16889
(see Selection Chart, column 4 and diagram Dx)

Dirt-holding capacity

Values in g test dust ISO MTD according to ISO 16889
(see Selection Chart, column 5).

Hydraulic fluids

Mineral oil and biodegradable fluids
(HEES and HETG, see info-sheet 00.20).

Temperature range

-30 °C ... +100 °C (temporary -40 °C ... +120 °C)
-22 °F ... +212 °F (temporary -40 °F ... +248 °F)

Viscosity at nominal flow rate

- › at operating temperature: $v < 60 \text{ mm}^2/\text{s}$ / 280 SUS
- › as starting viscosity: $v_{\text{max}} = 1200 \text{ mm}^2/\text{s}$ / 5560 SUS
- › at initial operation:
The recommended starting viscosity can be read from the diagram D (pressure drop as a function of the kinematic viscosity) as follows: Find the 70% Δp of the cracking pressure of the by-pass valve on the vertical axis. Draw a horizontal line so that it intersects the Δp curve at a point. Read this point on the horizontal axis for the viscosity.

Operating pressure

Max. 10 bar / 145 psi

Mounting position

Preferably vertical, outlet downwards.

Δp-curves for complete filters in Selection Chart, column 3

D1 Pressure drop as a function of the **flow volume**
at $v = 35 \text{ mm}^2/\text{s} / 162 \text{ SUS}$ (0 = casing empty)

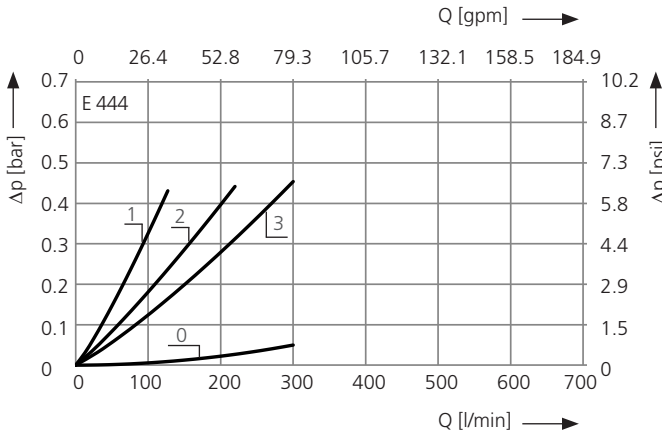

Pressure drop as a function of the **kinematic viscosity** at nominal flow

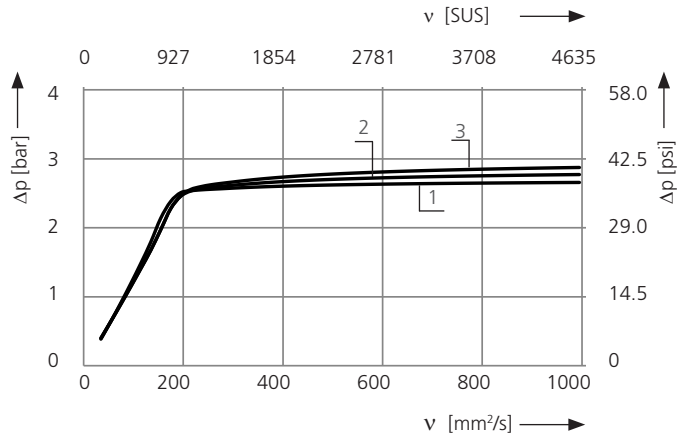

D2 Pressure drop as a function of the **flow volume**
at $v = 35 \text{ mm}^2/\text{s} / 162 \text{ SUS}$ (0 = casing empty)

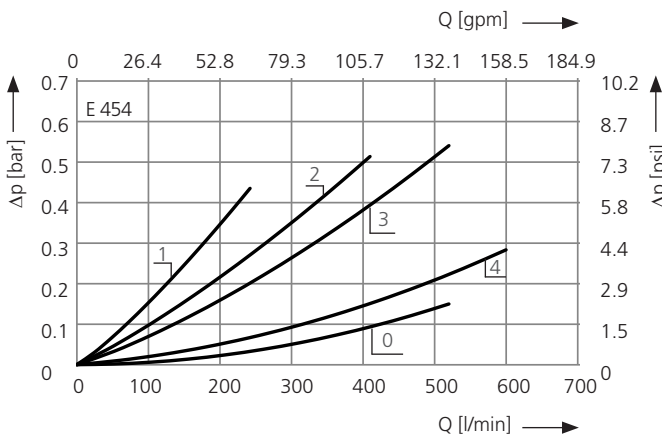

Pressure drop as a function of the **kinematic viscosity** at nominal flow

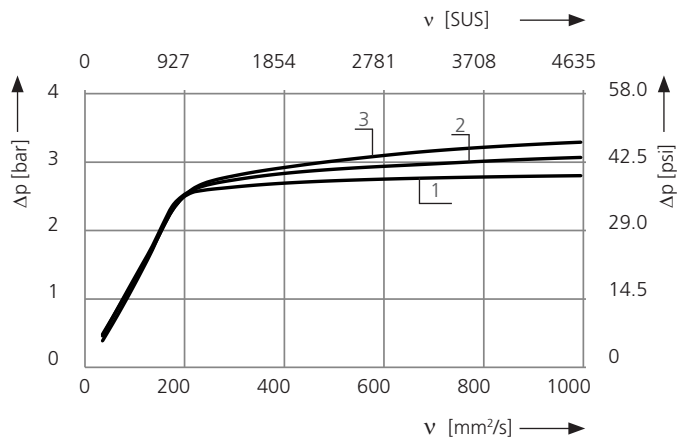

D3 Pressure drop as a function of the **flow volume**
at $v = 35 \text{ mm}^2/\text{s} / 162 \text{ SUS}$ (0 = casing empty)

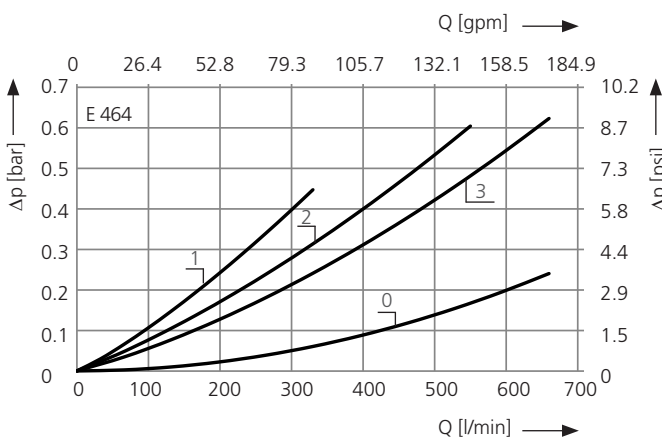

Pressure drop as a function of the **kinematic viscosity** at nominal flow

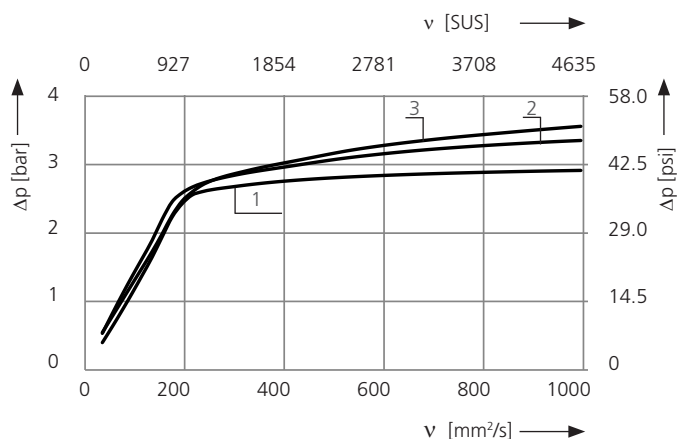

D4 Pressure drop as a function of the **flow volume** at $v = 35 \text{ mm}^2/\text{s} / 162 \text{ SUS}$ (0 = casing empty)

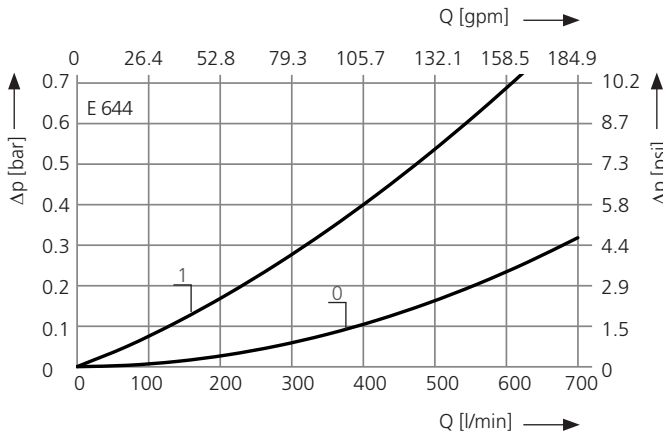

Pressure drop as a function of the **kinematic viscosity** at nominal flow

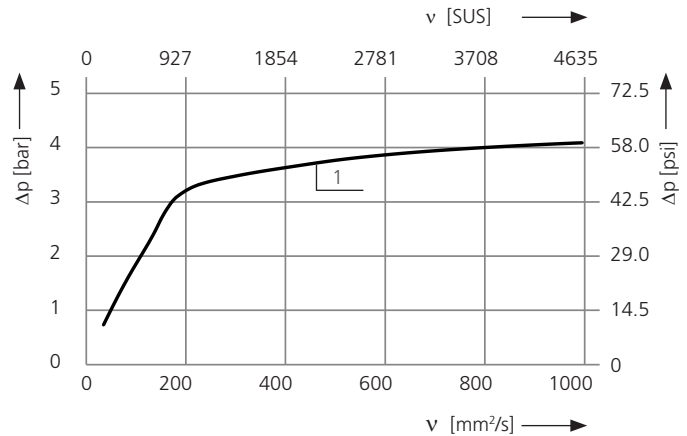

Filter fineness curves in Selection Chart, column 4

Dx Filtration ratio β as a function of particle size x obtained by the Multi-Pass-Test according to ISO 16889

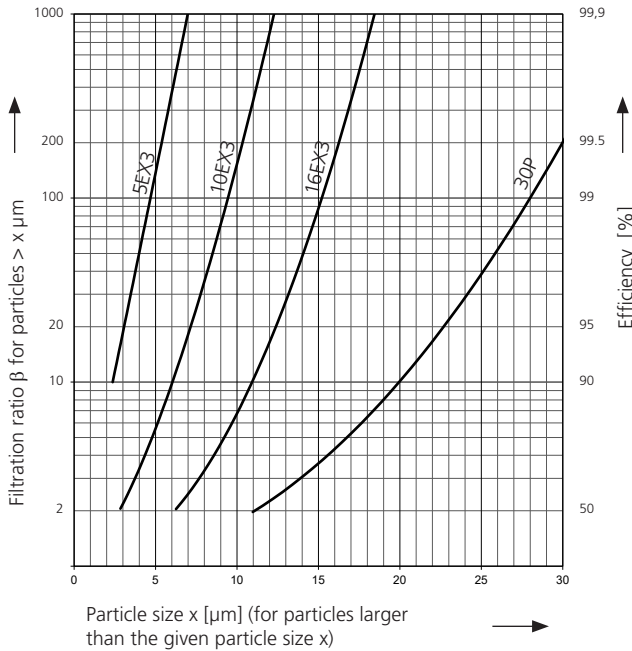

The abbreviations represent the following β -values resp. finenesses:

For EXAPOR®MAX 3 and Paper elements:

- 5EX3 = $\beta_{5(c)} = 200$ EXAPOR®MAX 3
- 10EX3 = $\beta_{10(c)} = 200$ EXAPOR®MAX 3
- 16EX3 = $\beta_{16(c)} = 200$ EXAPOR®MAX 3
- 30P = $\beta_{30(c)} = 200$ Paper

Based on the structure of the filter media of the 30P paper elements, deviations from the printed curves are quite probable.

For screen elements:

- 40S = screen material with mesh size 40 μm
- 60S = screen material with mesh size 60 μm
- 100S = screen material with mesh size 100 μm

Tolerances for mesh size according to DIN 4189

For special applications, finenesses differing from these curves are also available by using special composed filter media.

Selection Chart

Part No.	Nominal flow rate ²	Pressure drop see diagram D1 /curve no.	Filter fineness see Diagr. Dx	Dirt-holding capacity	Connection (A ₁ ... A ₄) SAE (3000 psi)	Cracking pressure of by-pass	Symbol	Replacement filter element Part No.	Weight	Remarks
	l/min			g		bar			kg	
1	2	3	4	5	6	7	8	9	10	11
E 444-459	115	D1/1	5EX3	73	2xG1¼/SAE1½, G¾+G1	2.5	3	V2.1217-53	4.4	-
E 444-456¹	200	D1/2	10EX3	71	2xG1¼/SAE1½, G¾+G1	2.5	3	V2.1217-56	4.4	-
E 444-468¹	270	D1/3	16EX3	77	2xG1¼/SAE1½, G¾+G1	2.5	3	V2.1217-58	4.4	-
E 454-459	220	D2/1	5EX3	150	2xG1¼/SAE1½, G¾+G1	2.5	3	V2.1234-23	6.1	-
E 454-456¹	375	D2/2	10EX3	150	2xG1¼/SAE1½, G¾+G1	2.5	3	V2.1234-26	6.1	-
E 454-468¹	480	D2/3	16EX3	150	2xG1¼/SAE1½, G¾+G1	2.5	3	V2.1234-28	6.1	-
E 454-400	525	D2/4	60S	(3600 cm ²)	2xG1¼/SAE1½, G¾+G1	1.5	6	S2.1234-00	6.4	with magnetic system
E 464-459	300	D3/1	5EX3	220	2xG1¼/SAE1½, G¾+G1	2.5	3	V2.1250-03	7.8	-
E 464-456¹	500	D3/2	10EX3	230	2xG1¼/SAE1½, G¾+G1	2.5	3	V2.1250-06	7.8	-
E 464-468¹	600	D3/3	16EX3	240	2xG1¼/SAE1½, G¾+G1	2.5	3	V2.1250-08	7.8	-
E 644-476¹	680	D4/1	10EX3	290	2xG1¼/SAE1½, G¾+G1	3.0	3	V2.1260-46	9.5	-

¹ Preferred type, no minimum order quantity required

² The individual flow rates must match the connections

³ Paper media supported with metal gauze

All filters are equipped as standard with a plugged clogging indicator connection M12 x 1.5 (mounting holes for differential pressure switches on request). As clogging indicators either manometers or electrical pressure switches can be used. Three different connection options are available for the filters. All filters are available with or without an outlet diffuser or air separation. The installation depth can be extended with a pipe on request. When ordering accessories, please use the codes listed below.

Order example: The filter E 454 has to be supplied with 2 connections (A and A₃), an outlet diffuser and an extension pipe for 564 mm (22.2 inch) length.

Order description:

E 454- 256 / VD / EV 564

Connections:

3 various options are available

one connection (A)

- G1½ / SAE 2 ————— 1

two connections² (A und A₃)

- G1½ / SAE 2 und G¾ ————— 2

four connections² (A₁, A₂, A₃ und A₄)

- 2 x G1¼ / SAE 1½, G¾ und G1 — 4

² The individual flow rates must match the connections

Options (bowl outlet) ⁴:

3 various options are available

VD: Outlet diffuser, RV: Extension pipe, AE - air separation AirEX

⁴ On request, the air separation can be combined with an extension pipe.

Extension pipe:

5 various lengths are available.

EV = K + 87 (3.43 inch) / + 142 (5.59 inch) / + 202 (7.95 inch) / + 237 (9.33 inch) / + 362 (14.25 inch)

(see section dimensions and measurements)

For the appropriate clogging indicators see catalog sheet 60.20.

Selection Chart

Part No.	Nominal flow rate ² gpm	Pressure drop see diagram D /curve no.	Filter fineness see Diagr. Dx	Dirt-holding capacity Filter surface in () g	Connection A ₁ und A ₃ SAE (3000 psi)	Cracking pressure of by-pass psi	Symbol	Replacement filter element Part No.	Weight lbs	Remarks
1	2	3	4	5	6	7	8	9	10	11
E 444-756¹	52.9	D1/2	10EX3	71	-24 ³ /SAE2, -16 ⁴	36	3	V2.1217-56	9.7	-
E 444-768¹	71.3	D1/3	16EX3	77	-24 ³ /SAE2, -16 ⁴	36	3	V2.1217-58	9.7	-
E 454-756¹	99.1	D2/2	10EX3	150	-24 ³ /SAE2, -16 ⁴	36	3	V2.1234-26	13.5	-
E 454-768¹	126.8	D2/3	16EX3	150	-24 ³ /SAE2, -16 ⁴	36	3	V2.1234-28	13.5	-
E 464-756¹	132.1	D3/2	10EX3	230	-24 ³ /SAE2, -16 ⁴	36	3	V2.1250-06	17.2	-
E 464-768¹	158.6	D3/3	16EX3	240	-24 ³ /SAE2, -16 ⁴	36	3	V2.1250-08	17.2	-
E 644-776¹	179.6	D4/1	10EX3	290	-24 ³ /SAE2, -16 ⁴	44	3	V2.1260-46	20.9	-

¹ Preferred type, no minimum order quantity required

² The individual flow rates must match with the connections

³ Corresponds to 1⁷/₈-12 UN-2B

⁴ Corresponds to 1⁵/₁₆-12 UN-2B

All filters are delivered with a plugged clogging indicator connection M12 x 1.5.

(Mounting holes for differential pressure switches on request).

As clogging indicators either manometers or electrical pressure switches can be used.

For the appropriate clogging indicators see catalog sheet 60.20.

Remarks:

- › The switching pressure of the electrical pressure switch has always to be lower than the cracking pressure of the by-pass valve (see Selection Chart, column 7).
- › Clogging indicators are optional and always delivered detached from the filter.
- › The filters listed in this chart are standard filters. Other designs available on request.

Dimensions

Version with 4 connections

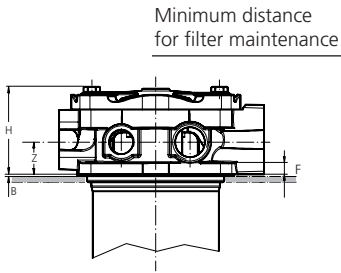

Tank surface sealing either with flat gasket E 442.0103 or O-ring N007.1375 (both items included in basic equipment)

Version with 1 or 2 connections

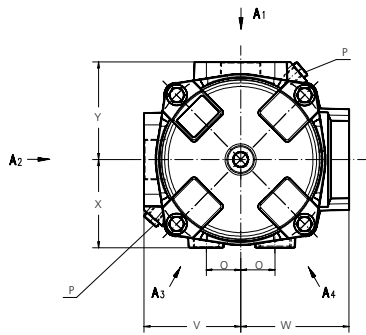
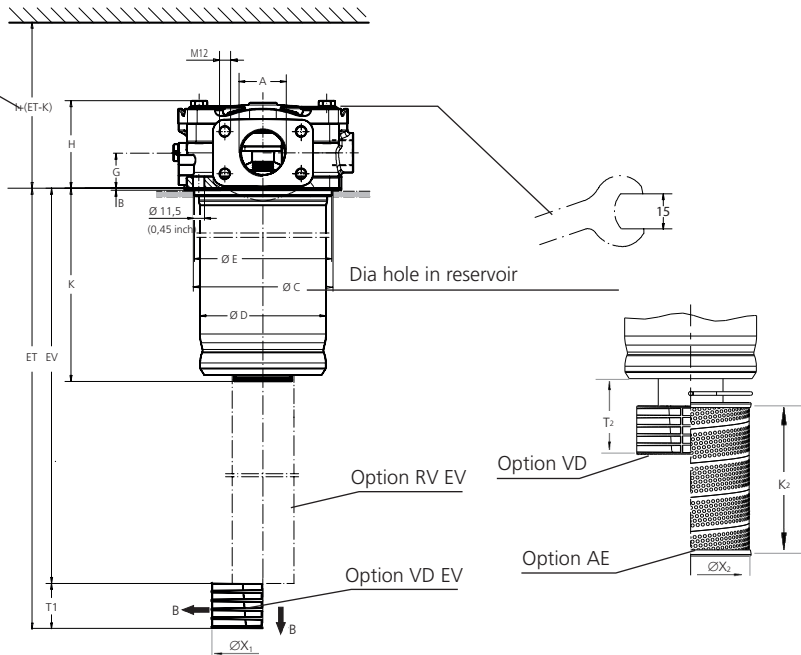

Connection M12 x 1.5 for clogging indicator standard (mounting holes for differential pressure switches on request)

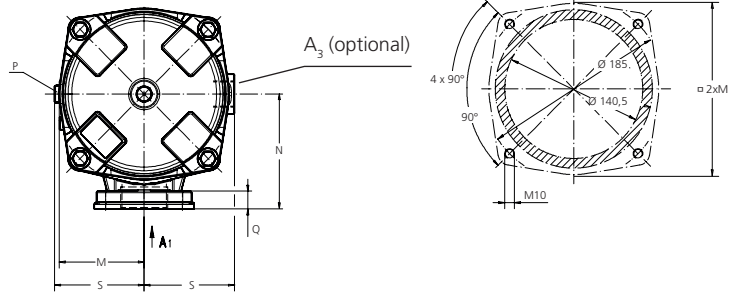

For calculation of dimension EV see selection chart

Measurements in mm

Type	A	B	C	D	E	F	G	H	I	K	K ₂	M	N	O	Q
E 444	see	2	141	128.5	139.9	12	36/35*	90	315	195	150	86.5	116	35	18
E 454	Selec-	2	141	128.5	139.9	12	36/35*	90	485	362	150	86.5	116	35	18
E 464	tion	2	141	128.5	139.9	12	36/35*	90	650	530	150	86.5	116	35	18
E 644	Chart	2	141	128.5	139.9	12	36/35*	90	750	630	150	86.5	116	35	18

Type	S	T ₁	T ₂	V	W	X	X ₁	X ₂	Y	Z					
E 444	92	47.5	64	98.5	110.5	89	105	118	98.5	32.5					
E 454	92	47.5	64	98.5	110.5	89	105	118	98.5	32.5					
E 464	92	47.5	64	98.5	110.5	89	105	118	98.5	32.5					
E 644	92	47.5	64	98.5	110.5	89	105	118	98.5	32.5					

Measurements in inch

Type	A	B	C	D	E	F	G	H	I	K	K ₂	M	N	O	Q
E 444	see	0.08	5.65	5.06	5.51	0.47	1.42/1.38*	3.54	12.40	7.67	5.91	3.40	4.57	1.38	0.71
E 454	Selec-	0.08	5.65	5.06	5.51	0.47	1.42/1.38*	3.54	19.09	14.25	5.91	3.40	4.57	1.38	0.71
E 464	tion	0.08	5.65	5.06	5.51	0.47	1.42/1.38*	3.54	25.59	20.87	5.91	3.40	4.57	1.38	0.71
E 644	Chart	0.08	5.65	5.06	5.51	0.47	1.42/1.38*	3.54	29.52	24.80	5.91	3.40	4.57	1.38	0.71

Type	S	T ₁	T ₂	V	W	X	X ₁	X ₂	Y	Z					
E 444	3.62	1.87	2.52	3.88	4.35	3.50	4.13	4.65	3.88	1.28					
E 454	3.62	1.87	2.52	3.88	4.35	3.50	4.13	4.65	3.88	1.28					
E 464	3.62	1.87	2.52	3.88	4.35	3.50	4.13	4.65	3.88	1.28					
E 644	3.62	1.87	2.52	3.88	4.35	3.50	4.13	4.65	3.88	1.28					

* For design with 4 connections

Symbols

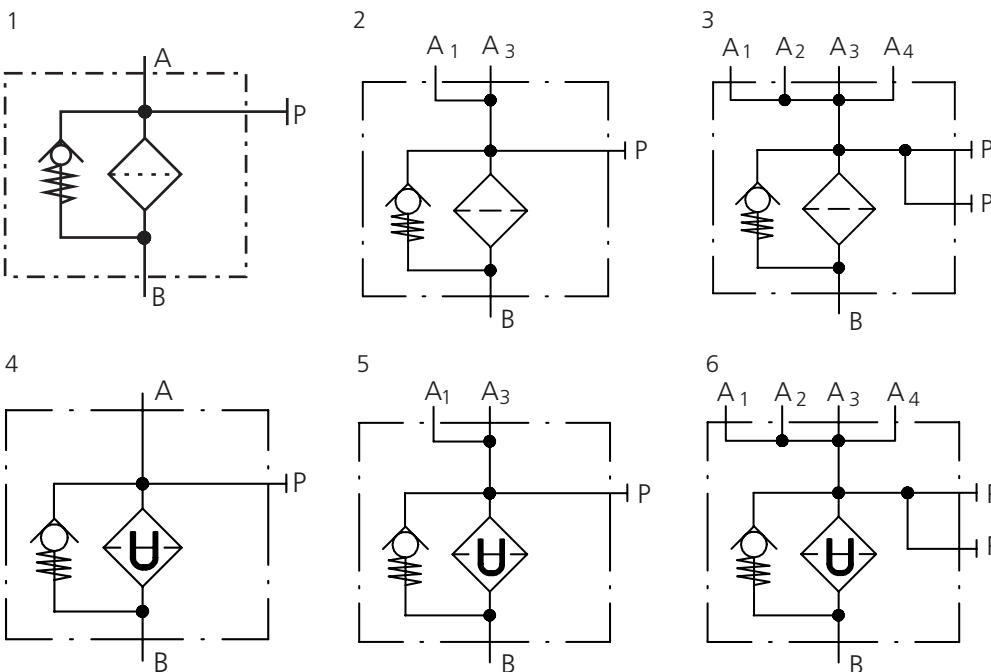

Spare Parts

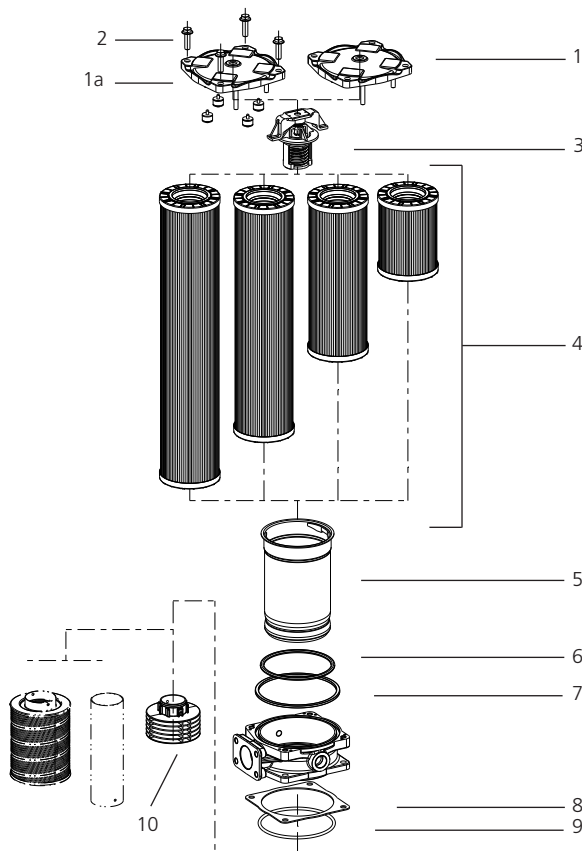

Pos.	Designation	Part No.
1	Cover	E 443.1200
1a	Cover with magnetic system	E 443.1210
2	Hexagon screw M10 x 35	28213600
3	By-pass (1.5 bar / 21 psi)	E 440.1500
3	By-pass (2.5 bar / 36 psi)	E 460.1520
3	By-pass (3.0 bar / 44 psi)	E 640.1510
4	Replacement filter elements	s. Chart / col. 9
5	Filter bowl E 444*	E 441.1900
5	Filter bowl E 454*	E 451.1900
5	Filter bowl E 464*	E 461.1900
5	Filter bowl E 644*	E 641.1900
6	O-ring 125 x 6 mm 4.92 x 0.24 inch	N007.1256
7	O-ring 151.76 x 5.33 mm 5.97 x 0.21 inch	N007.1525
8	Flat gasket	E 442.0103
9	O-ring 136.5 x 5.34 mm 5.37 x 0.21 inch	N007.1375
10	Diffusor (version VD)	E 441.0701

* Please indicate options (VD, VDEV, resp. RVEV)

The functions of the complete filters as well as the outstanding features of the filter elements assured by ARGO-HYTOS can only be guaranteed if original ARGO-HYTOS spare parts are used.

Quality Assurance

Quality management according to DIN EN ISO 9001

To ensure constant quality in production and operation, ARGO-HYTOS filter elements undergo strict controls and tests according to the following ISO standards:

ISO 2941	Verification of collapse / burst pressure rating
ISO 2942	Verification of fabrication integrity (Bubble Point Test)
ISO 2943	Verification of material compatibility with fluids
ISO 3968	Evaluation of pressure drop versus flow characteristics
ISO 16889	Multi-Pass-Test (evaluation of filter fineness and dirt-holding capacity)
ISO 23181	Determination of resistance to flow fatigue using high viscosity fluid

Various quality controls during the production process guarantee the leakfree function and solidity of our filters.

Illustrations may sometimes differ from the original. ARGO-HYTOS is not responsible for any unintentional mistake in this specification sheet.