

Pressure Filters

D 042 · D 062

In-line mounting · Operating pressure up to 100 bar / 1450 psi · Nominal flow rate up to 90 l/min / 23.8 gpm

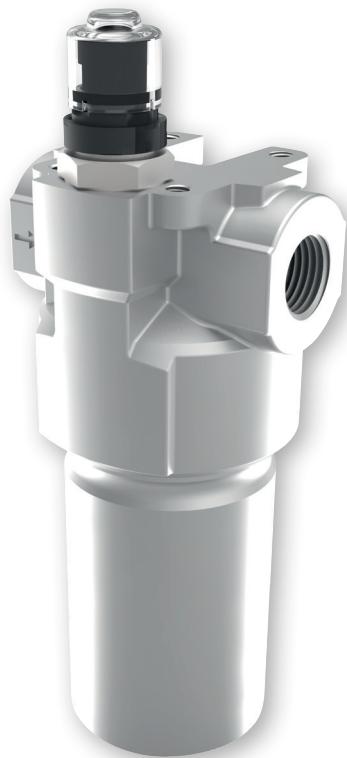

Pressure Filter D 042

Description

Application

In the pressure circuits of hydraulic and lubrication systems.

Performance features

Protection against wear:

By means of filter elements that even in full-flow filtration meet the highest demands regarding cleanliness classes.

Protection against malfunction:

Through installation near to the control valves or other expensive components. The specific determined flow rate guarantees a closed by-pass valve even at $v \leq 200 \text{ mm}^2/\text{s}$ / 927 SUS (cold start condition).

Filter elements

Flow direction from outside to center.

The star-shaped pleating of the filter material results in:

- › large filter surfaces
- › low pressure drop
- › high dirt-holding capacities
- › long service life

Filter maintenance

By using a clogging indicator the correct moment for maintenance is stated and guarantees the optimum utilization of the filter life.

Materials

Filter head:	Aluminum alloy
Filter bowl:	Aluminum alloy
Seals:	NBR (FPM on request)
Filter media:	EXAPOR®MAX 3 - inorganic multi-layer microfiber web

Clogging indicators

Electrical and / or optical clogging indicators can be integrated in the filter head if desired. For dimensions and technical data see catalog sheet 60.40.

Suitable retrofittable indicators - optionally with one or two switching points or temperature compensation - can be found in catalog sheet 60.30.

Operating pressure

0 ... 63 bar / 914 psi, min. 3×10^6 pressure cycles
Nominal pressure according to DIN 24550

0 ... 100 bar / 1450 psi, min. 10^4 pressure cycles
Quasi-static operating pressure

Permissible pressures for other numbers of cycles

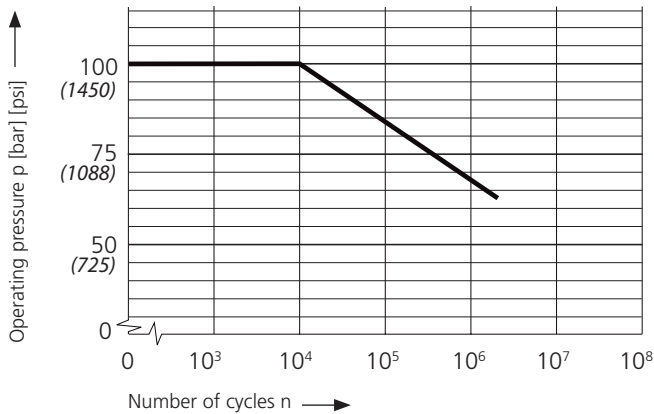

Nominal flow rate

Up to 90 l/min / 23.7 gpm (see Selection Chart, column 2)
The nominal flow rates indicated by ARGO-HYTOS are based on the following features:

- › closed by-pass valve at $v \leq 200 \text{ mm}^2/\text{s}$ / 927 SUS
- › element service life > 1000 operating hours at an average fluid
- › contamination of 0.07 g per l/min / 0.27 g per gpm flow volume
- › flow velocity in the connection lines:
up to 100 bar $\leq 6 \text{ m/s}$ / 1450 psi $\leq 19.7 \text{ ft/s}$

Filter fineness

5 $\mu\text{m(c)}$... 16 $\mu\text{m(c)}$
 β -values according to ISO 16889
(see Selection Chart, column 4 and diagram Dx).

Dirt-holding capacity

Values in g test dust ISO MTD according to ISO 16889
(see Selection Chart, column 5).

Hydraulic fluids

Mineral oil and biodegradable fluids
(HEES and HETG, see info-sheet 00.20).

Temperature range

-30 °C ... +100 °C (temporary -40 °C ... +120 °C)
-22 °F ... +212 °F (temporary -40 °F ... +248 °F)

Viscosity at nominal flow rate

- › at operating temperature: $v < 60 \text{ mm}^2/\text{s}$ / 280 SUS
- › as starting viscosity: $v_{\text{max}} = 1200 \text{ mm}^2/\text{s}$ / 5560 SUS
- › at initial operation:
The recommended starting viscosity can be read from the diagram D (pressure drop as a function of the kinematic viscosity) as follows: Find the 70% Δp of the cracking pressure of the by-pass valve on the vertical axis. Draw a horizontal line so that it intersects the Δp curve at a point. Read this point on the horizontal axis for the viscosity.

Mounting position

Preferably vertical, filter head on top.

Connection

Threaded ports according to

- › ISO 228 or DIN 13
- › SAE standard J514

Sizes see Selection Chart, column 6
(other port threads on request).

For installation recommendations, see info sheet 00.325.

Δp-curves for complete filters in Selection Chart, column 3

D1 Pressure drop as a function of the **flow volume** at $v = 35 \text{ mm}^2/\text{s} / 162 \text{ SUS}$ (0 = casing empty)

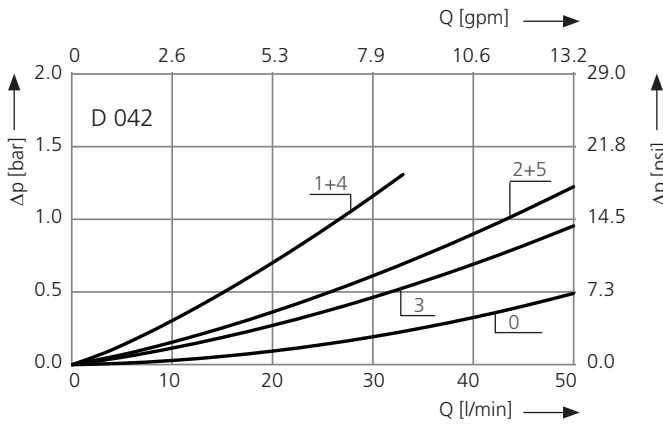

Pressure drop as a function of the **kinematic viscosity** at nominal flow

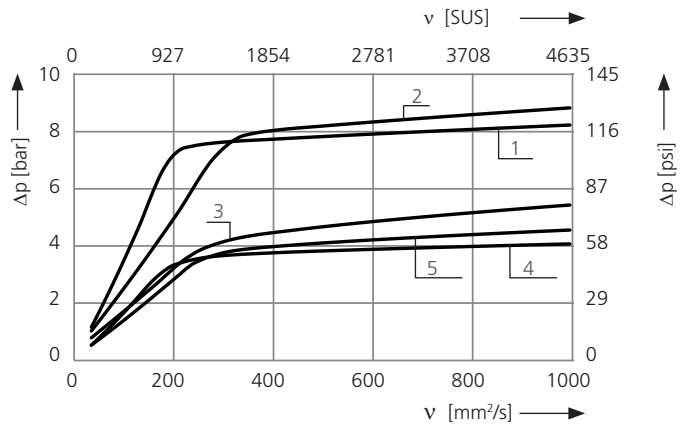

D2 Pressure drop as a function of the **flow volume** at $v = 35 \text{ mm}^2/\text{s} / 162 \text{ SUS}$ (0 = casing empty)

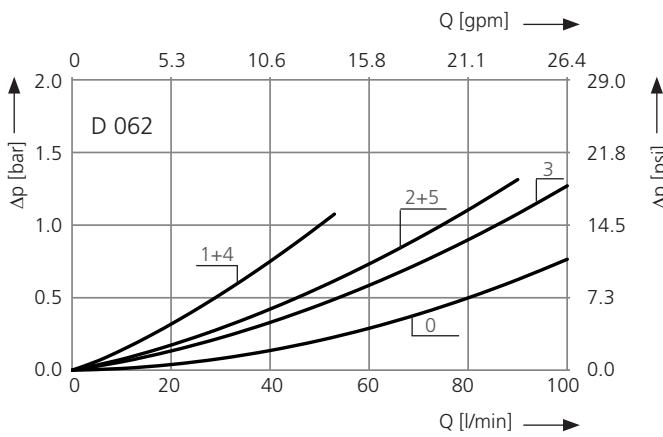

Pressure drop as a function of the **kinematic viscosity** at nominal flow

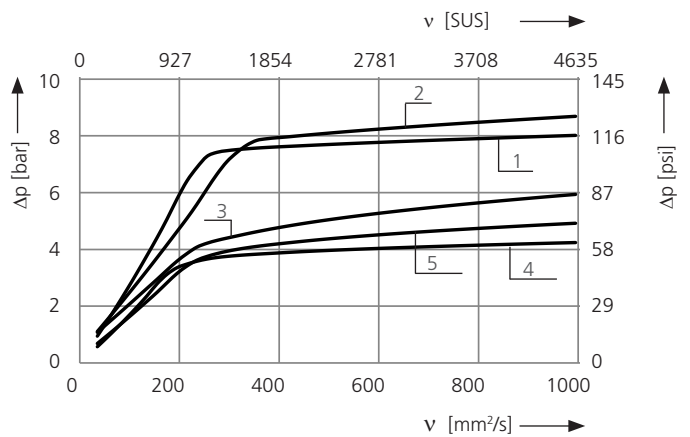

Filter fineness curves in Selection Chart, column 4

Dx Filtration ratio β as a function of particle size x obtained by the Multi-Pass-Test according to ISO 16889

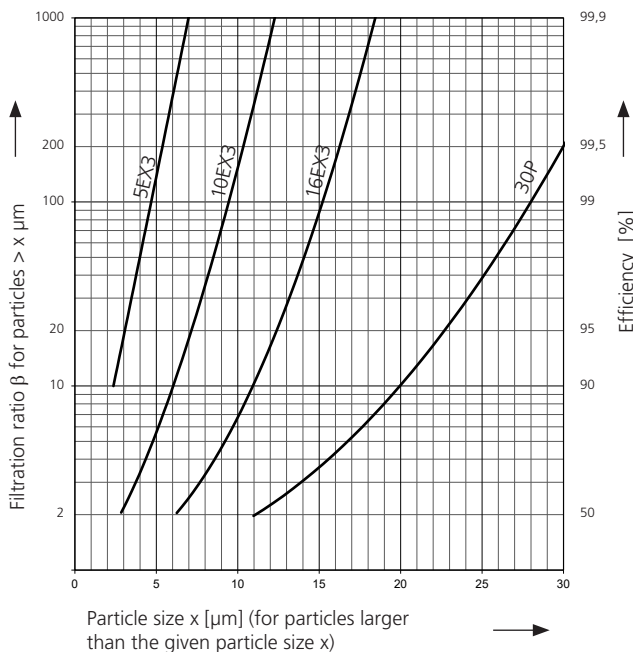

The abbreviations represent the following β -values resp. finenesses:

- For EXAPOR®MAX3 and Paper elements:**
- 5EX3 = $\beta_{5(c)} = 200$ EXAPOR®MAX 3
 - 10EX3 = $\beta_{10(c)} = 200$ EXAPOR®MAX 3
 - 16EX3 = $\beta_{16(c)} = 200$ EXAPOR®MAX 3
 - 30P = $\beta_{30(c)} = 200$ Paper

Based on the structure of the filter media of the 30P paper elements, deviations from the printed curves are quite probable.

For special applications, finenesses differing from these curves are also available by using special composed filter media.

Selection Chart

Part No.	Nominal flow rate	Pressure drop see diagram D /curve no.	Filter fineness see diagram Dx	Dirt-holding capacity	Connection A/B	Cracking pressure of by-pass	Symbol	Replacement filter element Part No.	Weight	Clogging indicator	Remarks
1	l/min	3	4	g	bar	8	9	10	11	12	
D 042-153	16	D1 /1	5EX3	5.6	G½	3.5	1	V3.0510-03	0.8	retrofittable	-
D 042-156¹	27	D1 /2	10EX3	6.8	G½	3.5	1	V3.0510-06	0.8	retrofittable	-
D 042-158¹	44	D1 /3	16EX3	6.9	G½	3.5	1	V3.0510-08	0.8	retrofittable	-
D 042-183	30	D1 /5	5EX3	5.6	G½	7	1	V3.0510-03	0.8	retrofittable	-
D 042-186	44	D1 /6	10EX3	6.8	G½	7	1	V3.0510-06	0.8	retrofittable	-
D 062-153	32	D2 /1	5EX3	12	G½	3.5	1	V3.0520-03	1.1	retrofittable	-
D 062-156¹	57	D2 /2	10EX3	14	G¾	3.5	1	V3.0520-06	1.1	retrofittable	-
D 062-158¹	90	D2 /3	16EX3	15	G¾	3.5	1	V3.0520-08	1.1	retrofittable	-
D 062-183	48	D2 /5	5EX3	12	G½	7	1	V3.0520-03	1.1	retrofittable	-
D 062-196	80	D2 /6	10EX3	14	G¾	7	1	V3.0520-06	1.1	retrofittable	-

¹ Preferred type, no minimum order quantity required

Optical or electrical clogging indicators can be provided for clogging monitoring. When ordering filters with integrated monitoring, the clogging indicator code must be added to the order number of the desired filter variant (basic unit) (to be found in catalog sheet 60.40, column 2)

Suitable clogging indicators can be found in catalog sheet 60.40. The required version of the clogging indicator is specified by the code (selection charts, column 2).

Order example: The filter D 042-153 is to be supplied with an optical indicator with automatic reset.

Order code: D 042-153 OD1

Part No. (Basic unit) _____

Clogging indicator _____

Further clogging indicators can be found in catalog sheet 60.30. These must be ordered separately and fitted by the customer. Installation instructions are enclosed.

Remarks:

- › The switching pressure of the clogging indicator has always to be lower than the cracking pressure of the by-pass valve (see Selection Chart, column 7).
- › The filters listed in this chart are standard filters. Other designs available on request.
- › For versions with electrical clogging indicator, the device socket is not included in the scope of delivery.
- › For the electrical clogging indicator of type DIN EN 175301-803 (ED8 and ED9), a device socket with two LEDs is available, which additionally enables visual indication of the filter contamination (order no. DG 041.1200).

Selection Chart

Part No.	Nominal flow rate	Pressure drop see diagram D /curve no.	Filter fineness see diagram Dx	Dirt-holding capacity	Connection A/B	Cracking pressure of by-pass	Symbol	Replacement filter element Part No.	Weight	Clogging indicator	Remarks
1	gpm	3	g	SAE	psi	8	9	lbs	11	12	
D 042-753	4.2	D1 /1	5EX3	5.6	-8 ²	51	1	V3.0510-03	1.8	retrofitable	-
D 042-756¹	7.1	D1 /2	10EX3	6.8	-8 ²	51	1	V3.0510-06	1.8	retrofitable	-
D 042-758¹	11.6	D1 /3	16EX3	6.9	-8 ²	51	1	V3.0510-08	1.8	retrofitable	-
D 042-783	7.9	D1 /5	5EX3	5.6	-8 ²	102	1	V3.0510-03	1.8	retrofitable	-
D 042-786	11.6	D1 /6	10EX3	6.8	-8 ²	102	1	V3.0510-06	1.8	retrofitable	-
D 062-753	8.5	D2 /1	5EX3	12	-8 ²	51	1	V3.0520-03	2.4	retrofitable	-
D 062-756¹	15.1	D2 /2	10EX3	14	-12 ³	51	1	V3.0520-06	2.4	retrofitable	-
D 062-758¹	23.8	D2 /3	16EX3	15	-12 ³	51	1	V3.0520-08	2.4	retrofitable	-
D 062-783	12.7	D2 /5	5EX3	12	-8 ²	102	1	V3.0520-03	2.4	retrofitable	-
D 062-786	21.1	D2 /6	10EX3	14	-12 ³	102	1	V3.0520-06	2.4	retrofitable	-

¹ Preferred type, no minimum order quantity required

² Corresponds to 3/4-16 UNF-2B

³ Corresponds to 1/16-12 UN-2B

Optical or electrical clogging indicators can be provided for clogging monitoring. When ordering filters with integrated monitoring, the clogging indicator code must be added to the order number of the desired filter variant (basic unit) (to be found in catalog sheet 60.40, column 2)

Suitable clogging indicators can be found in catalog sheet 60.40. The required version of the clogging indicator is specified by the code (selection charts, column 2).

Order example: The filter D 042-753 is to be supplied with an optical indicator with automatic reset.

Order code: **D 042-753 OD1**

Part No. (Basic unit) _____

Clogging indicator _____

Further clogging indicators can be found in catalog sheet 60.30. These must be ordered separately and fitted by the customer. Installation instructions are enclosed.

Remarks:

- › The switching pressure of the clogging indicator has always to be lower than the cracking pressure of the by-pass valve (see Selection Chart, column 7).
- › The filters listed in this chart are standard filters. Other designs available on request.
- › For versions with electrical clogging indicator, the device socket is not included in the scope of delivery.
- › For the electrical clogging indicator of type DIN EN 175301-803 (ED8 and ED9), a device socket with two LEDs is available, which additionally enables visual indication of the filter contamination (order no. DG 041.1200).

Dimensions

Version with integrated optical clogging indicator (OD2)

Version with integrated electrical clogging indicator (ED8) and device socket*

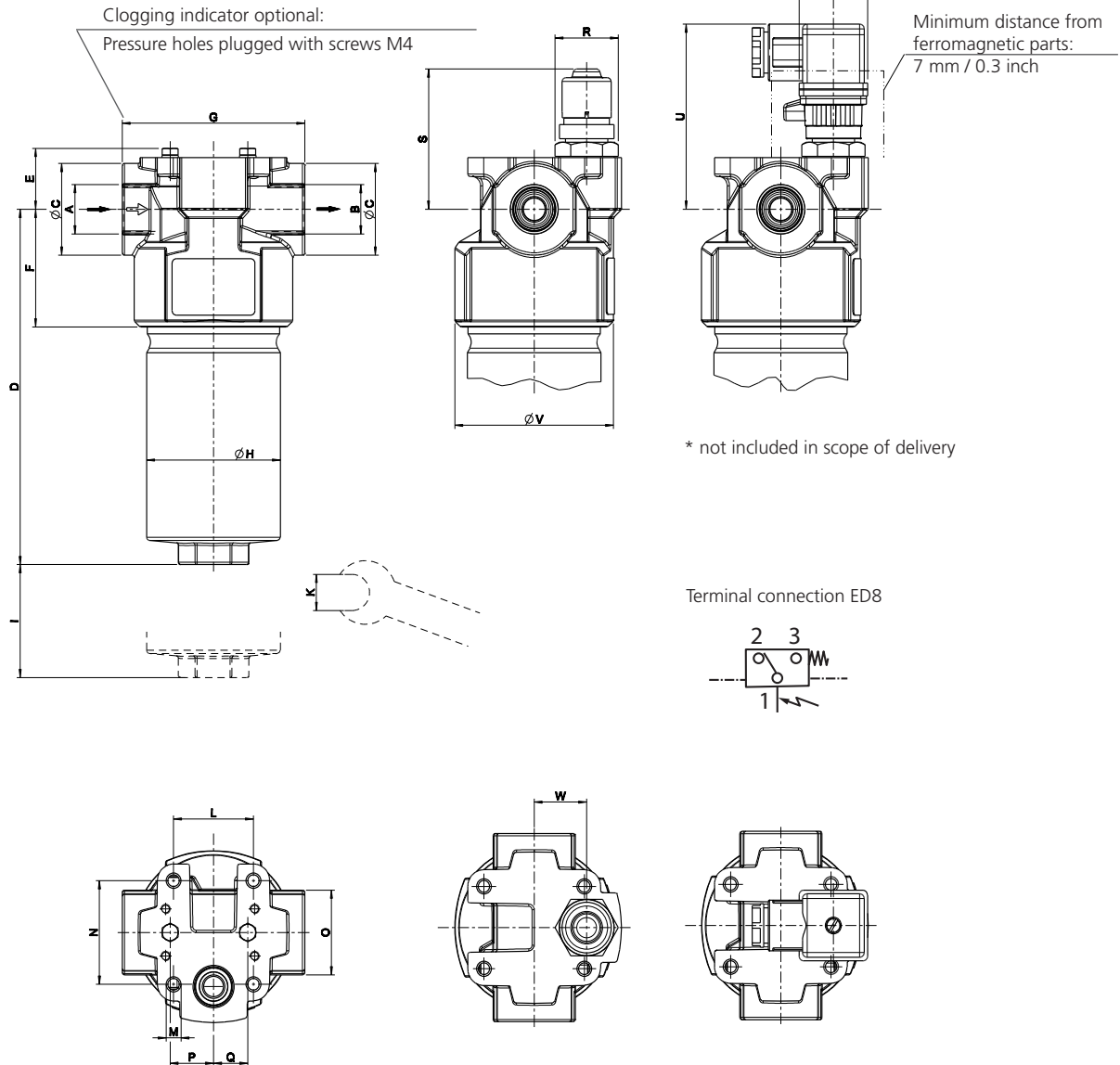

Measurements in mm

Type	A/B	C	D	E	F	G	H	I	K	L	M Ø/depth	N	O	P	Q	R	S	T	U	V	W
D 042	G½	39	153	27	50	80	58.5	55	27	35	M6 / 8	44	AF 36	19	15	AF 24	60	□ 30	79	70	23
D 062	G½, G¾	39	249	27	50	80	58.5	55	27	35	M6 / 8	44	AF 36	19	15	AF 24	60	□ 30	79	70	23

Measurements in inch

Type	A/B SAE	C	D	E	F	G	H	I	K	L	M Ø/depth	N	O mm	P	R mm	S
D 042	-8	1.54	6.02	1.06	1.97	3.15	2.30	2.17	1.06	1.38	M6 / 0.32	1.73	AF 36	0.75	AF 24	2.36
D 062	-8 / -12	1.54	9.80	1.06	1.97	3.15	2.30	2.17	1.06	1.38	M6 / 0.32	1.73	AF 36	0.75	AF 24	2.36

Type	T	U	V	W
D 042	□ 1.18	3.11	7.76	0.91
D 062	□ 1.18	3.11	7.76	0.91

Symbols

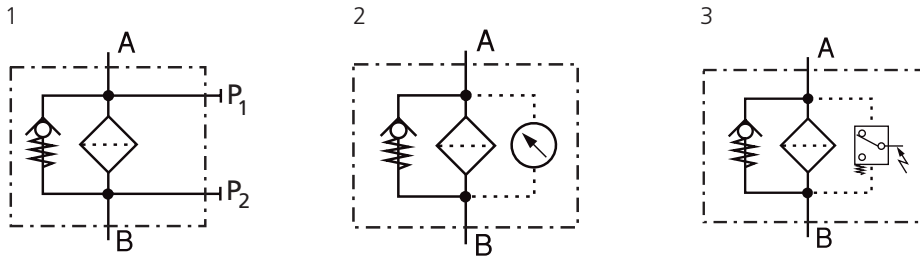

Spare Parts

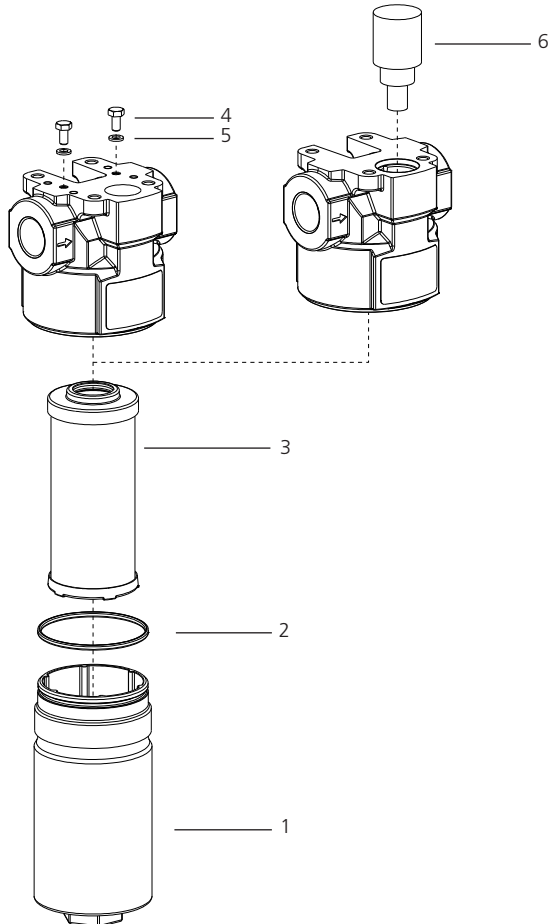

Pos.	Designation	Part No.
1	Filter bowl D 042	D 044.0101
1	Filter bowl D 062	D 064.0101
2	O-ring 50 x 2 mm 1.97 x 0.08 inch	N007.0501
3	Replacement filter element (with seal)	s. Chart / col. 9
4	Hexagon screw M4 x 8 DIN 933-8.8	11385800
5	Bonded seal 4.1 x 7.2 x 1 mm 0.16 x 0.28 x 0.04 inch	12504600
6	Clogging indicator (with seal)	see data sheet 60.40

The functions of the complete filters as well as the outstanding features of the filter elements assured by ARGO-HYTOS can only be guaranteed if original ARGO-HYTOS spare parts are used.

Quality Assurance

Quality management according to DIN EN ISO 9001

To ensure constant quality in production and operation, ARGO-HYTOS filter elements undergo strict controls and tests according to the following ISO standards:

- ISO 2941 Verification of collapse / burst pressure rating
- ISO 2942 Verification of fabrication integrity (Bubble Point Test)
- ISO 2943 Verification of material compatibility with fluids
- ISO 3968 Evaluation of pressure drop versus flow characteristics
- ISO 16889 Multi-Pass-Test (evaluation of filter fineness and dirt-holding capacity)
- ISO 23181 Determination of resistance to flow fatigue using high viscosity fluid

Before release into the series production the filter casing is tested for fatigue strength in our pressure pulse test rig. Various quality controls during the production process guarantee the leakfree function and solidity of our filters.

Illustrations may sometimes differ from the original. ARGO-HYTOS is not responsible for any unintentional mistake in this specification sheet.