

## DG 041, DG 042, DG 023, DG 024



Mounting clogging indicators on pressure and high-pressure filters  
*Montage von Verschmutzungsanzeigen auf Druck- und Hochdruckfiltern*

Filter series                    D 042 / D 062  
*Filter-Baureihen*                D 162 / D 232 / D 332  
    HD 044 / HD 064  
    HD 417 / HD 617  
    HD 314 / HD 414 / HD 614  
    HD 790 / HD 990



## DG 041, DG 042, DG 023, DG 024

### Step 1 / Schritt 1

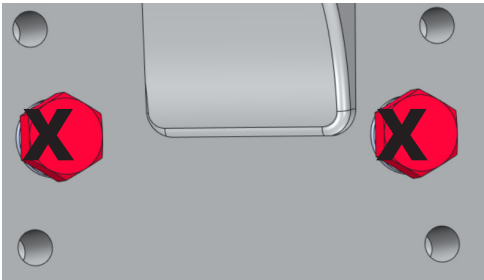

Remove screw plugs with seal from filter head

*Verschlusschrauben mit Dichtung vom Filterkopf entfernen*

### Step 2 / Schritt 2

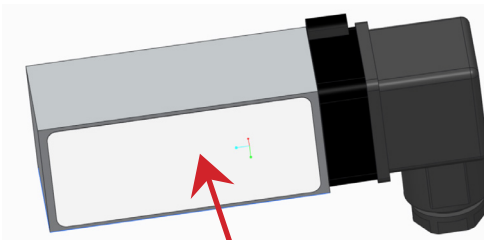

**Remove sticker /  
Etikett entfernen**

Consider the filtration direction  
FILTER IN and FILTER OUT

*Beachten Sie die Filtrationsrichtung  
FILTER EIN und FILTER AUS*

Anzugmoment der 4 Befestigungsschrauben / torque of the 4 fixing screws:  $2 \pm 0.2 \text{ Nm}$

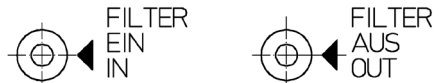

Vor Montage Schutzstreifen abziehen  
Remove sticker before mounting

O-ring must remain in the housing  
after removing the label

*O-Ring muss nach Entfernen des  
Etiketts im Gehäuse verbleiben*

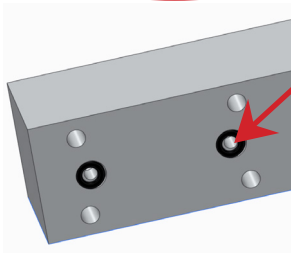

Appropriate mounting kit included in the scope of  
delivery: spring washer (4x) and cylinder screw (4x)

*Entsprechender Montagesatz im Lieferumfang enthal-  
ten: Federscheibe (4x) und Zylinderschraube (4x)*

DG 020.1710 for (für) DG 024 ; DG 041 ; DG 042  
DG 020.1730 for (für) DG 023

## DG 041, DG 042, DG 023, DG 024

### Step 3 / Schritt 3

Mounting the clogging indicator on the pressure filter **D 042 / D 062**

Montage der Verschmutzungsanzeige auf den Druckfilter **D 042 / D 062**

Lubricate / grease all O-rings before installation



Alle O-Ringe vor der Montage schmieren / fetten

Torque of the 4 fixings screws:  $2 \pm 0.2$  Nm  
Anzugsmoment der 4 Befestigungsschrauben:  $2 \pm 0,2$  Nm

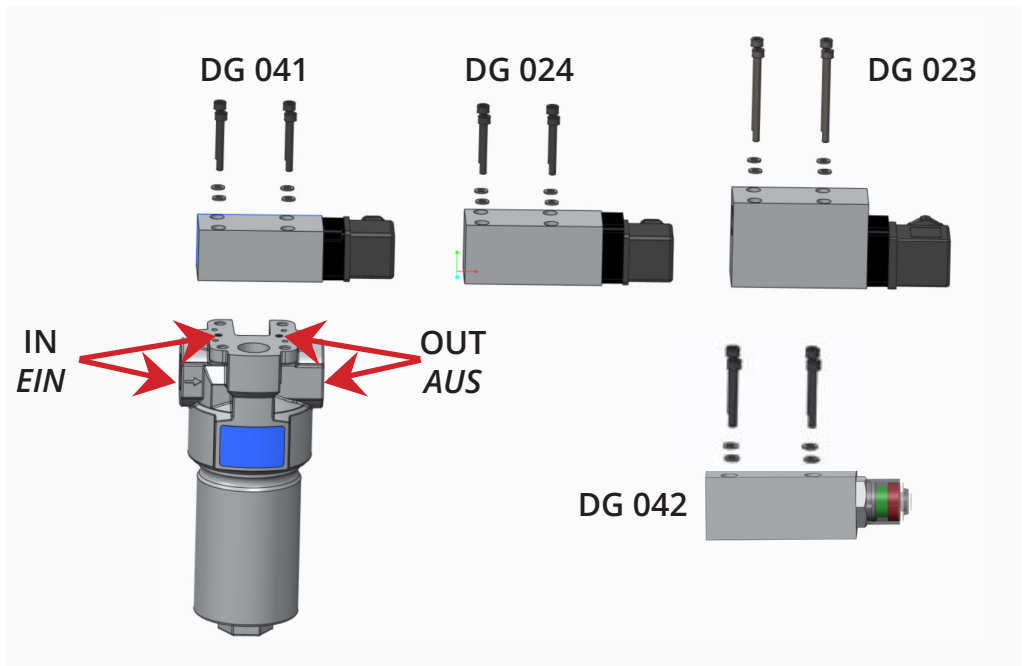

#### Caution / Achtung:

Observe correct position IN/EIN to IN/EIN and OUT/AUS to OUT/AUS  
Richtige Position IN/EIN zu IN/EIN und OUT/AUS zu OUT/AUS beachten

Installation Manual / Montageanleitung

**DG 041, DG 042, DG 023, DG 024**

Step 3 / Schritt 3

Mounting the clogging indicator on the pressure filter **D 162 / D 232 / D 332**

Montage der Verschmutzungsanzeige auf den Druckfilter **D 162 / D 232 / D 332**

Lubricate / grease all O-rings before installation



Alle O-Ringe vor der Montage schmieren / fetten

Torque of the 4 fixings screws:  $2 \pm 0.2$  Nm  
Anzugsmoment der 4 Befestigungsschrauben:  $2 \pm 0,2$  Nm

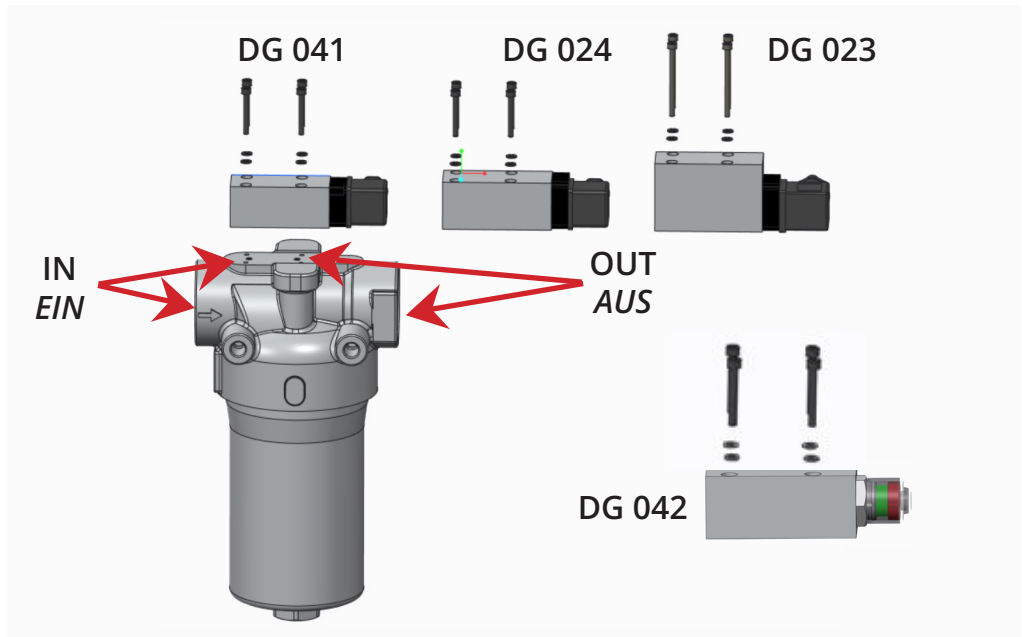

**Caution / Achtung:**

Observe correct position IN/EIN to IN/EIN and OUT/AUS to OUT/AUS  
Richtige Position IN/EIN zu IN/EIN und OUT/AUS zu OUT/AUS beachten

Installation Manual / Montageanleitung

**DG 041, DG 042, DG 023, DG 024**

Step 3 / Schritt 3

Mounting the clogging indicator on the high pressure filter **HD 044 / HD 064**

Montage der Verschmutzungsanzeige auf den Hochdruckfilter **HD 044 / HD 064**

Lubricate / grease all O-rings before installation



Alle O-Ringe vor der Montage schmieren / fetten

Torque of the 4 fixings screws:  $2 \pm 0.2$  Nm  
Anzugsmoment der 4 Befestigungsschrauben:  $2 \pm 0,2$  Nm

DG 023

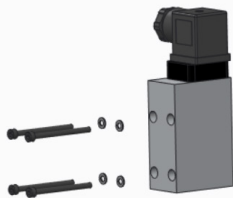

DG 024

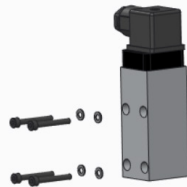

DG 041

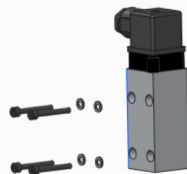

DG 042

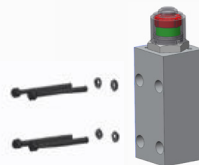

OUT  
AUS

IN  
EIN

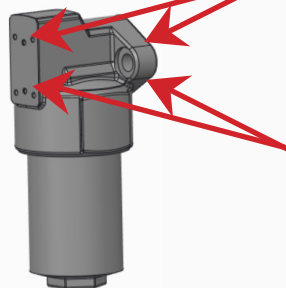

**Caution / Achtung:**

Observe correct position IN/EIN to IN/EIN and OUT/AUS to OUT/AUS

Richtige Position IN/EIN zu IN/EIN und OUT/AUS zu OUT/AUS beachten

## DG 041, DG 042, DG 023, DG 024

### Step 3 / Schritt 3

Mounting the clogging indicator on the high pressure filter **HD 417 / HD 617**

Montage der Verschmutzungsanzeige auf den Hochdruckfilter **HD 417 / HD 617**

Lubricate / grease all O-rings before installation



Alle O-Ringe vor der Montage schmieren / fetten

Torque of the 4 fixings screws:  $2 \pm 0.2$  Nm  
Anzugsmoment der 4 Befestigungsschrauben:  $2 \pm 0,2$  Nm

DG 023

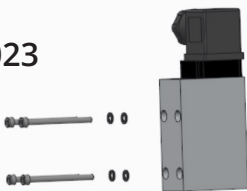

DG 024

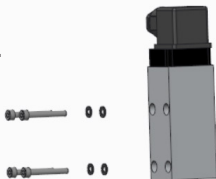

DG 041

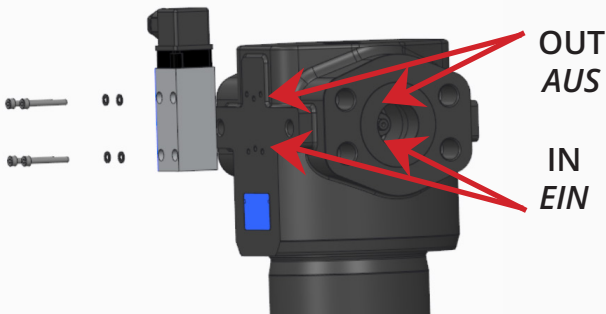

DG 042

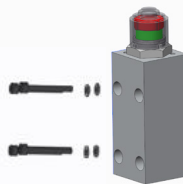

#### Caution / Achtung:

Observe correct position IN/EIN to IN/EIN and OUT/AUS to OUT/AUS

Richtige Position IN/EIN zu IN/EIN und OUT/AUS zu OUT/AUS beachten

Installation Manual / Montageanleitung

**DG 041, DG 042, DG 023, DG 024**

Step 3 / Schritt 3

Mounting the clogging indicator on the high pressure filter **HD 314 / HD 414 / HD 614**

Montage der Verschmutzungsanzeige auf den Hochdruckfilter **HD 314 / HD 414 / HD 614**

Lubricate / grease all O-rings before installation



Alle O-Ringe vor der Montage schmieren / fetten

Torque of the 4 fixings screws:  $2 \pm 0.2$  Nm  
Anzugsmoment der 4 Befestigungsschrauben:  $2 \pm 0,2$  Nm

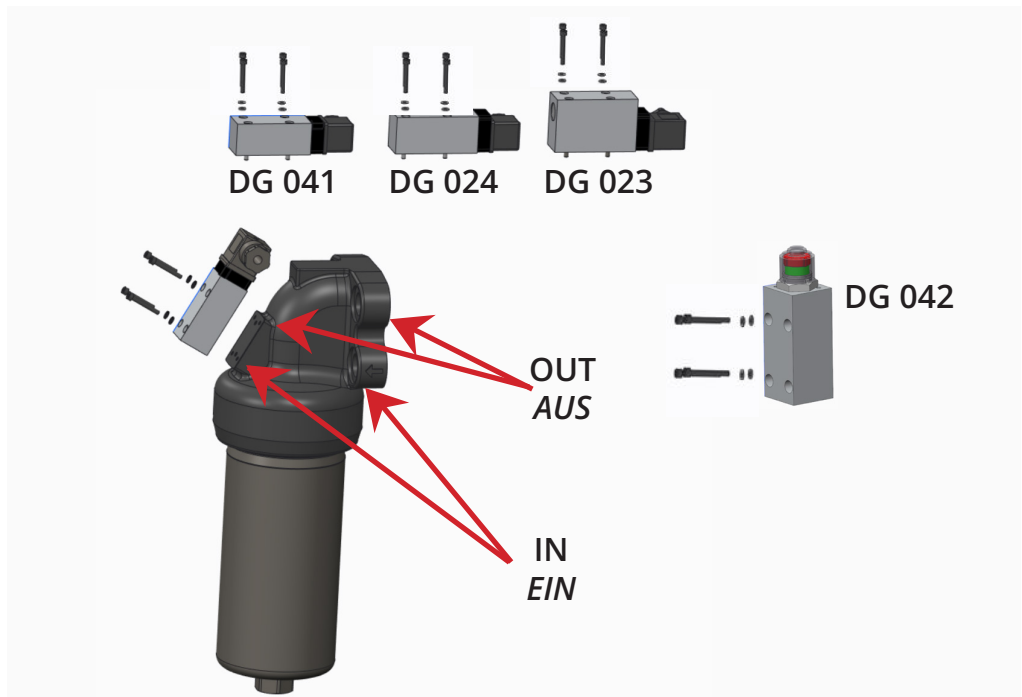

**Caution / Achtung:**

Observe correct position IN/EIN to IN/EIN and OUT/AUS to OUT/AUS  
Richtige Position IN/EIN zu IN/EIN und OUT/AUS zu OUT/AUS beachten

## DG 041, DG 042, DG 023, DG 024

### Step 3 / Schritt 3

Mounting the clogging indicator on the high pressure filter **HD 790 / HD 990**

Montage der Verschmutzungsanzeige auf den Hochdruckfilter **HD 790 / HD 990**

Lubricate / grease all O-rings before installation



Alle O-Ringe vor der Montage schmieren / fetten

Torque of the 4 fixings screws:  $2 \pm 0.2$  Nm  
Anzugsmoment der 4 Befestigungsschrauben:  $2 \pm 0,2$  Nm

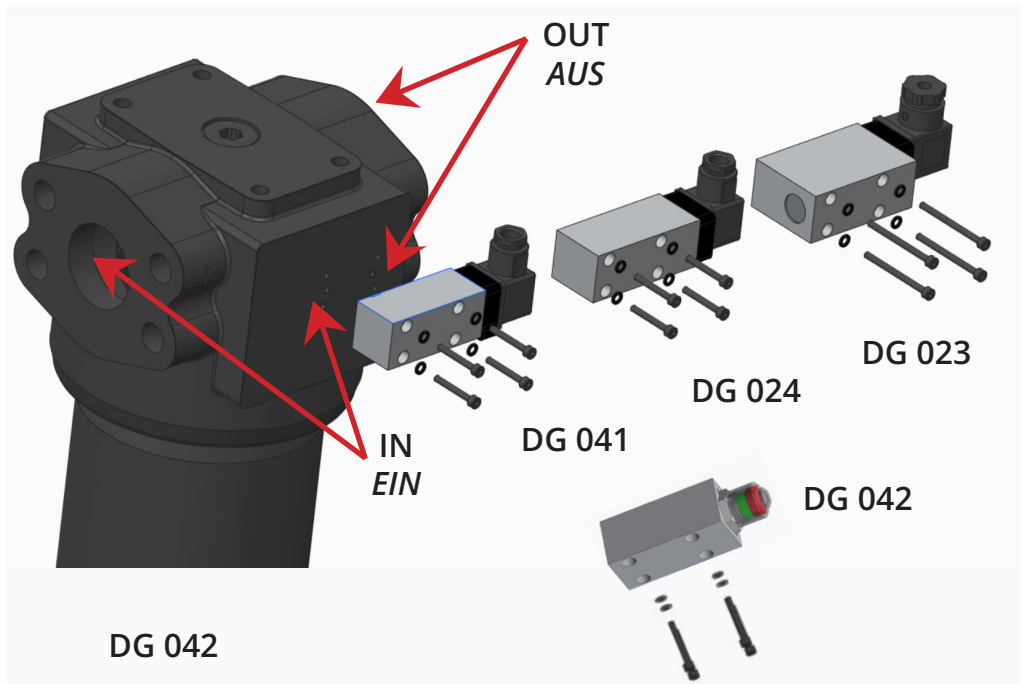

#### Caution / Achtung:

Observe correct position IN/EIN to IN/EIN and OUT/AUS to OUT/AUS  
Richtige Position IN/EIN zu IN/EIN und OUT/AUS zu OUT/AUS beachten